

# **Service Guide**

## **Agilent Technologies**

### **PSG Signal Generators**

This guide applies to the signal generator models listed below. Due to our continuing efforts to improve our products through firmware and hardware revisions, signal generator design and operation may vary from descriptions in this guide. We recommend that you use the latest revision of this guide to ensure you have up-to-date product information. Compare the print date of this guide (see bottom of this page) with the latest revision, which can be downloaded from the website shown below.

**E8247C PSG CW**  
**E8257C PSG Analog**  
**E8267C PSG Vector**

*[www.agilent.com/find/signalgenerators](http://www.agilent.com/find/signalgenerators)*



**Part Number: E8251-90259**

**Printed in USA**

**March 2003**

© Copyright 2002, 2003 Agilent Technologies.

---

## Notice

The material contained in this document is provided “as is”, and is subject to being changed, without notice, in future editions.

Further, to the maximum extent permitted by applicable law, Agilent disclaims all warranties, either express or implied with regard to this manual and to any of the Agilent products to which it pertains, including but not limited to the implied warranties of merchantability and fitness for a particular purpose. Agilent shall not be liable for errors or for incidental or consequential damages in connection with the furnishing, use, or performance of this document or any of the Agilent products to which it pertains. Should Agilent have a written contract with the User and should any of the contract terms conflict with these terms, the contract terms shall control.

---

## Questions or Comments about our Documentation?

We welcome any questions or comments you may have about our documentation. Please send us an E-mail at [sources\\_manuals@am.exch.agilent.com](mailto:sources_manuals@am.exch.agilent.com).

**1. Troubleshooting**

Electrostatic Discharge (ESD) Information . . . . .	1-2
Handling of Electronic Components and ESD . . . . .	1-2
Getting Started with Troubleshooting . . . . .	1-3
Running Self-Test . . . . .	1-3
A18 CPU Turn-On Test . . . . .	1-4
Failure Symptoms . . . . .	1-4
A2 Display Not Functioning or A2 Display Not Functioning After Turn-on . . . . .	1-4
A18 CPU Fails to Complete the Turn-On Check . . . . .	1-4
Checking the A18 CPU Voltages . . . . .	1-5
Verifying the A18 CPU Turn-On Sequence . . . . .	1-5
No Instrument Control From the Front Panel . . . . .	1-6
Error Messages . . . . .	1-6
Self-Test Failures and Related Troubleshooting . . . . .	1-7
Troubleshooting Assembly-Level Problems . . . . .	1-10
Front Panel Display Assembly Troubleshooting . . . . .	1-11
Power Supply Troubleshooting . . . . .	1-17
Self-Tests 1xx for the A13 I/Q Multiplexer . . . . .	1-30
Self-Tests 2xx: A5 Sampler Self-Test Errors . . . . .	1-32
Self-Tests 3xx: A7 Reference (Standard) Self-Test Errors . . . . .	1-34
Self-Tests 4xx: A8 Output Self-Test Errors . . . . .	1-35
Self-Tests 6xx: A9 YIG Driver Self-Test Errors . . . . .	1-38
Self-Tests 7xx: A6 Frac-N Self-Test Errors . . . . .	1-41
Self-Tests 9xx: A10 ALC Self-Test Errors . . . . .	1-45
Self-Tests 10xx: A7 Reference (Option UNR) Self-Test Errors . . . . .	1-47
Self-Tests 11xx: A18 CPU Self-Test Errors . . . . .	1-49
Self-Tests 12xx: A26 MID Self-Test Errors . . . . .	1-51
Self-Tests 13xx: A11 Analog/Pulse Modulation Generator Self-Test Errors . . . . .	1-56
Self-Tests 16xx for the A14 Baseband Generator (Option 002) . . . . .	1-59
Self-Tests 22xx: A8 Output Self-Test Errors . . . . .	1-62
Troubleshooting Unlocks . . . . .	1-64
508 A6 Frac-N Loop Unlock . . . . .	1-64
513 1 GHz Out of Lock . . . . .	1-64
514 Reference Oven Cold . . . . .	1-64
515 10 MHz Signal Bad . . . . .	1-65
520 Sampler Unlocked . . . . .	1-65
521 YO Loop Unlocked . . . . .	1-65
625 Internal Pulse Generator Unlock . . . . .	1-66
626 Internal Mod Source Unlock . . . . .	1-66

---

# Contents

Troubleshooting Unlevels . . . . .	1-67
Troubleshoot and correct any unlock problems before troubleshooting unlevelled problems. . . . .	1-67
Troubleshooting Adjustment Problems . . . . .	1-71
Troubleshooting ADC Adjustment Failures. . . . .	1-73
Troubleshooting Performance Test Problems . . . . .	1-74
Troubleshooting the RF Path . . . . .	1-76
ALC and RF problems. . . . .	1-76
Troubleshooting Pulse Modulation . . . . .	1-77
Troubleshooting AT1 Attenuator . . . . .	1-79
Troubleshooting Harmonic Spurious . . . . .	1-80
20 GHz Models . . . . .	1-80
20 GHz Models . . . . .	1-81
40 GHz Models Only . . . . .	1-81
Troubleshooting Non-Harmonic Spurious. . . . .	1-83
Troubleshooting Option UNR Phase Noise . . . . .	1-84
Overall Description . . . . .	1-85
A19 Power Supply . . . . .	1-85
A18 CPU . . . . .	1-86
Input/Output Interface . . . . .	1-86
Frequency Generation . . . . .	1-87
Overall PSG Analog Signal Generator. . . . .	1-91
Overall PSG Vector Signal Generator . . . . .	1-93
Reference/Synthesis Loop Description . . . . .	1-95
A7 Reference . . . . .	1-96
A5 Sampler (CW mode only). . . . .	1-97
A6 Frac-N . . . . .	1-97
A9 YIG Driver . . . . .	1-98
A28 YIG Oscillator (YO). . . . .	1-99
A29 20 GHz Doubler . . . . .	1-99
Reference/Synthesis Loop . . . . .	1-101
RF Path Description (Frequency Generation, Level Control, and Modulation). . . . .	1-103
A29 20 GHz Doubler . . . . .	1-103
A6 Frac-N . . . . .	1-104
A8 Output . . . . .	1-104
A30 Modulation Filter . . . . .	1-105
A27 40 GHz Doubler (Analog Models Only) . . . . .	1-105
A23 Low Band Coupler/Detector, A24 High Band Coupler, and A25 High Band Detector . . . . .	1-105
<3.2 GHz Fast Pulse Modulator (Option 1E6). . . . .	1-106



A35 3–20 GHz I/Q Modulator (Vector Models Only) . . . . .	1-106
ALC Loop . . . . .	1-106
Modulation (AM, FM, $\Phi$ M, and Pulse) . . . . .	1-107
Digital Modulation . . . . .	1-108
Approximate Device Gains and Losses . . . . .	1-110
Analog RF Path . . . . .	1-111
Vector RF Path . . . . .	1-113
Self-Test Overview . . . . .	1-115
How self-test works: . . . . .	1-115
Independent failures . . . . .	1-115
Contacting Agilent Technologies . . . . .	1-116
Agilent Sales and Service Offices . . . . .	1-117
Packaging a Signal Generator for Return . . . . .	1-118
<b>2. Assembly Replacement</b>	
Before You Replace an Assembly . . . . .	2-2
After Replacing or Repairing an Assembly . . . . .	2-2
Assemblies That You Can Replace . . . . .	2-3
Outer Instrument Cover . . . . .	2-5
Tools Required . . . . .	2-5
Removal Procedure . . . . .	2-5
Replacement Procedure . . . . .	2-5
Inner Instrument Cover . . . . .	2-7
Tools Required . . . . .	2-7
Removal Procedure . . . . .	2-7
Replacement Procedure . . . . .	2-7
Front Panel . . . . .	2-9
Tools Required . . . . .	2-9
Removal Procedure . . . . .	2-9
Replacement Procedure . . . . .	2-10
A1 Keyboard . . . . .	2-12
Tools Required . . . . .	2-12
Removal Procedure . . . . .	2-12
Replacement Procedure . . . . .	2-12
A2 Display . . . . .	2-14
Tools Required . . . . .	2-14
Removal Procedure . . . . .	2-14
Replacement Procedure . . . . .	2-14
A2DS1 Display Backlight . . . . .	2-16
Tools Required . . . . .	2-16

---

# Contents

Removal Procedure	2-16
Replacement Procedure	2-16
A3 Power Switch	2-18
Tools Required	2-18
Removal Procedure	2-18
Replacement Procedure	2-18
A4 Inverter	2-20
Tools Required	2-20
Removal Procedure	2-20
Replacement Procedure	2-20
A5 Sampler, A6 Frac-N, A7 Reference (Standard and Option UNR), and A8 Output	2-22
Tools Required	2-22
Removal Procedure	2-22
Replacement Procedure	2-22
A9 YIG Driver	2-24
Tools Required	2-24
Removal Procedure	2-24
Replacement Procedure	2-24
A10 ALC	2-26
Tools Required	2-26
Removal Procedure	2-26
Replacement Procedure	2-26
A11 Pulse/Analog Modulation Generator	2-28
Tools Required	2-28
Removal Procedure	2-28
Replacement Procedure	2-28
A12 Pulse Modulator Board (Option 1E6)	2-30
Tools Required	2-30
Removal Procedure	2-30
Replacement Procedure	2-30
A13 I/Q MUX (E8267C Models Only)	2-32
Tools Required	2-32
Removal Procedure	2-32
Replacement Procedure	2-32
A14 Baseband Generator (E8267C Models Only)	2-34
Tools Required	2-34
Removal Procedure	2-34
Replacement Procedure	2-34
A17 Baseband Generator Interface (E8267C Models Only)	2-36
Tools Required	2-36

Removal Procedure . . . . .	2-36
Replacement Procedure . . . . .	2-36
A18 CPU . . . . .	2-38
Tools Required . . . . .	2-38
Removal Procedure . . . . .	2-38
Replacement Procedure . . . . .	2-38
A18BT1 . . . . .	2-40
Tools Required . . . . .	2-40
Removal Procedure . . . . .	2-40
Replacement Procedure . . . . .	2-40
A19 Power Supply . . . . .	2-42
Tools Required . . . . .	2-42
Removal Procedure . . . . .	2-42
Replacement Procedure . . . . .	2-42
Rear Panel (Standard) . . . . .	2-44
Tools Required . . . . .	2-44
Removal Procedure . . . . .	2-44
Replacement Procedure . . . . .	2-45
Rear Panel (Option 1EM) . . . . .	2-47
Tools Required . . . . .	2-47
Removal Procedure . . . . .	2-47
Replacement Procedure . . . . .	2-48
A20 SMI (Source Module Interface) . . . . .	2-50
Tools Required . . . . .	2-50
Removal Procedure . . . . .	2-50
Replacement Procedure . . . . .	2-50
A21 Rear-Panel Interface . . . . .	2-52
Tools Required . . . . .	2-52
Removal Procedure . . . . .	2-52
Replacement Procedure . . . . .	2-52
A22 Line Module . . . . .	2-54
Tools Required . . . . .	2-54
Removal Procedure . . . . .	2-54
Replacement Procedure . . . . .	2-54
AT1 115 dB Attenuator . . . . .	2-56
Tools Required . . . . .	2-56
Removal Procedure . . . . .	2-56
Replacement Procedure . . . . .	2-56
AT1 115 dB Attenuator (Option 1EM) . . . . .	2-58
Tools Required . . . . .	2-58

---

# Contents

Removal Procedure . . . . .	2-58
Replacement Procedure . . . . .	2-58
A23 Low Band Coupler/Detector . . . . .	2-60
Tools Required . . . . .	2-60
Removal Procedure . . . . .	2-60
Replacement Procedure . . . . .	2-60
A24 20 GHz Highband Coupler (Option 520 Only) . . . . .	2-62
Tools Required . . . . .	2-62
Removal Procedure . . . . .	2-62
Replacement Procedure . . . . .	2-62
A24 40 GHz Highband Coupler (Option 540 Only) . . . . .	2-64
Tools Required . . . . .	2-64
Removal Procedure . . . . .	2-64
Replacement Procedure . . . . .	2-64
A25 20 GHz Highband Detector . . . . .	2-66
Tools Required . . . . .	2-66
Removal Procedure . . . . .	2-66
Replacement Procedure . . . . .	2-66
A25 40 GHz Highband Detector (Option 540 Only) . . . . .	2-68
Tools Required . . . . .	2-68
Removal Procedure . . . . .	2-68
Replacement Procedure . . . . .	2-68
A25B Highband Detector Bias Board . . . . .	2-70
Tools Required . . . . .	2-70
Removal Procedure . . . . .	2-70
Replacement Procedure . . . . .	2-70
A26 MID (Microcircuit Interface Deck) . . . . .	2-72
Tools Required . . . . .	2-72
Removal Procedure . . . . .	2-72
Replacement Procedure . . . . .	2-72
A27 40 GHz Doubler (Option 540 Models Only) . . . . .	2-74
Tools Required . . . . .	2-74
Removal Procedure . . . . .	2-74
Replacement Procedure . . . . .	2-74
A28 YIG Oscillator . . . . .	2-76
Tools Required . . . . .	2-76
Removal Procedure . . . . .	2-76
Replacement Procedure . . . . .	2-76
A29 20 GHz Doubler . . . . .	2-78
Tools Required . . . . .	2-78

Removal Procedure . . . . .	2-78
Replacement Procedure . . . . .	2-78
A30 Modulation Filter (Standard and Option 1EA) . . . . .	2-80
Tools Required . . . . .	2-80
Removal Procedure . . . . .	2-80
Replacement Procedure . . . . .	2-81
A31 Motherboard (E8247C/57C) . . . . .	2-83
Tools Required . . . . .	2-83
Removal Procedure . . . . .	2-83
Replacement Procedure . . . . .	2-84
A31 Motherboard (E8267C) . . . . .	2-86
Tools Required . . . . .	2-86
Removal Procedure . . . . .	2-86
Replacement Procedure . . . . .	2-87
A32 10 MHz Crystal Oscillator (Option UNR) . . . . .	2-90
Tools Required . . . . .	2-90
Removal Procedure . . . . .	2-90
Replacement Procedure . . . . .	2-90
A33 6 dB PAD . . . . .	2-92
Tools Required . . . . .	2-92
Removal Procedure . . . . .	2-92
Replacement Procedure . . . . .	2-92
A34 Internal Hard Drive (E8267C Models Only) . . . . .	2-94
Tools Required . . . . .	2-94
Removal Procedure . . . . .	2-94
Replacement Procedure . . . . .	2-94
A35 3-20 GHz I/Q Modulator (E8267C Models Only) . . . . .	2-96
Tools Required . . . . .	2-96
Removal Procedure . . . . .	2-96
Replacement Procedure . . . . .	2-96
B1 Fan . . . . .	2-98
Tools Required . . . . .	2-98
Removal Procedure . . . . .	2-98
Replacement Procedure . . . . .	2-98
<b>3. Replaceable Parts</b>	
Ordering Information . . . . .	3-2
Call (800) 227-8164 to Order Parts Fast (U.S. Only) . . . . .	3-2
Save Money with Rebuilt-Exchange Assemblies . . . . .	3-3
Shipping a Defective Assembly Back to Agilent Technologies . . . . .	3-4

---

# Contents

Frequency, Hardware, and Personality Options .....	3-5
Assemblies and Hardware Options .....	3-6
Assemblies from the Inside Front Panel View .....	3-9
Assemblies from a Top View .....	3-10
Assemblies from the Inside Rear Panel View .....	3-12
Assemblies from a Microcircuit Deck View .....	3-14
Assemblies from a Bottom View .....	3-16
A18BT1 Lithium Battery .....	3-18
Cables .....	3-19
Inside Front Panel .....	3-26
Top View .....	3-27
Rear Panel (Standard) .....	3-29
Rear Panel (Option 1EM) .....	3-31
Microcircuit Deck View .....	3-32
Bottom View .....	3-34
Hardware .....	3-37
Front Panel View .....	3-38
Disassembled Front Panel View .....	3-40
Disassembled Rear Panel View .....	3-42
Disassembled A32 10 MHz Crystal Oscillator (Option UNR) .....	3-45
Disassembled AT1 115 dB Attenuator View (Option 1E1) .....	3-47
Disassembled A24 20 GHz High Band Coupler and A25B Highband Detector Bias Board .....	3-48
Disassembled A24 40GHz High Band Coupler and A25B High Band Detector Bias Board .....	3-49
Microcircuit Interface Deck Top View .....	3-50
Main Chassis and MID Bottom View .....	3-52
2.4 mm RF Output Connector (Option 540 Only) .....	3-55
APC 3.5 RF Output Connector (Option 520 Only) .....	3-56
Type-N RF Output Connector (Option 1ED Models Only) .....	3-57
Main Chassis with Inside Cover and Right-Side Support Wall .....	3-58
Outer and Inner Instrument Covers and Associated Parts .....	3-59
Miscellaneous .....	3-61
Accessories .....	3-61
Documentation .....	3-61
Electrostatic Discharge (ESD) Protective Supplies .....	3-62
Abbreviations Used in Part Descriptions .....	3-63
<b>4. Post-Repair Procedures</b>	
Post-Repair Procedures Matrix .....	4-2

**5. Safety and Regulatory**

General Safety Considerations .....5-2

Lithium Battery Disposal .....5-3

Assistance .....5-3

Certification .....5-3

---

# Contents



---

# 1 Troubleshooting

- “Electrostatic Discharge (ESD) Information” on page 1-2
- “Getting Started with Troubleshooting” on page 1-3
- “A18 CPU Turn-On Test” on page 1-4
- “Self-Test Failures and Related Troubleshooting” on page 1-7
- “Troubleshooting Assembly-Level Problems” on page 1-10
- “Troubleshooting Unlocks” on page 1-64
- “Troubleshooting Unlevels” on page 1-67
- “Troubleshooting Adjustment Problems” on page 1-71
- “Troubleshooting ADC Adjustment Failures” on page 1-73
- “Troubleshooting Performance Test Problems” on page 1-74
- “Troubleshooting the RF Path” on page 1-76
- “Troubleshooting Harmonic Spurious” on page 1-80
- “Troubleshooting Non-Harmonic Spurious” on page 1-83
- “Troubleshooting Option UNR Phase Noise” on page 1-84
- “Overall Description” on page 1-85
- “Reference/Synthesis Loop Description” on page 1-95
- “RF Path Description (Frequency Generation, Level Control, and Modulation)” on page 1-103
- “Self-Test Overview” on page 1-115
- “Contacting Agilent Technologies” on page 1-116

---

**WARNING**    **Troubleshooting instructions are for use by qualified personal only. To avoid electrical shock, do not perform any troubleshooting unless qualified.**

**The opening of covers or removal of parts is likely to expose dangerous voltages. Disconnect the signal generator from all voltage sources before it is opened.**

---

## Electrostatic Discharge (ESD) Information

---

**WARNING** The following techniques related to ESD and static-safe workstations should not be used when working on circuitry with a voltage potential greater than 500 volts.

---

ESD can damage or destroy electronic components. All work on electronic assemblies should be performed at a static-safe workstation using two types of static-safe workstation protection:

- conductive table-mat and wrist-strap combination
- conductive floor-mat and heel-strap combination

Both types, when used together, provide a significant level of ESD protection. Of the two, only the table-mat and wrist-strap combination provides adequate ESD protection when used alone. To ensure user safety, the static-safe accessories must provide at least 1 M $\Omega$  of isolation from ground.

## Handling of Electronic Components and ESD

---

**CAUTION** Many of the assemblies in this instrument are very susceptible to damage from ESD. Perform troubleshooting procedures only at a static-safe workstation, and wear a grounding strap.

*Always* handle a printed circuit board assembly by its edges. This reduces the possibility of ESD damage to components, and prevent contamination of exposed plating.

---

The possibility of unseen damage caused by ESD is present whenever components are transported, stored, or used. The risk of ESD damage can be greatly reduced by close attention to how all components are handled.

- Perform work on all components at a static-safe workstation.
- Keep static-generating materials at least one meter away from all components.
- Store or transport components in static-shielding containers.

## Getting Started with Troubleshooting

Referring to [Table 1-1](#):

- determine where to begin troubleshooting
- work on problems in the order they are presented in the table
- use the descriptions provided in this chapter that explain how the signal generator operates, and the function of each assembly: the overall description ([page 1-85](#)), the synthesis loop ([page 1-95](#)), the RF path ([page 1-103](#)), and self-test ([page 1-115](#)).

**Table 1-1**

If able to run self-test...	Go to this section...
Run Self-Test	<a href="#">“Running Self-Test” on page 1-3</a> and refer to <a href="#">“Self-Test Failures and Related Troubleshooting” on page 1-7</a> .
If unable to run self-test, check...	Go to this section...
Power supply failures	<a href="#">“Power Supply Troubleshooting” on page 1-17</a>
A18 CPU turn-on failures	<a href="#">“A18 CPU Turn-On Test” on page 1-4</a>
Front panel display or keyboard operations	<a href="#">“Front Panel Display Assembly Troubleshooting” on page 1-11</a>
If other conditions occur...	Go to this section...
Unlocked Conditions	<a href="#">“Troubleshooting Unlocks” on page 1-64</a>
Uneveled Conditions	<a href="#">“Troubleshooting Unevels” on page 1-67</a>
Adjustment Problems	<a href="#">“Troubleshooting Adjustment Problems” on page 1-71</a>
Performance Test Problems	<a href="#">“Troubleshooting Performance Test Problems” on page 1-74</a>

### Running Self-Test

1. On the instrument front panel, press the **Utility** hardkey.
2. Select the following softkeys:
  - a. **Instrument Info/Help Mode**
  - b. **Self Test**
  - c. **Run Complete Self Test**

## A18 CPU Turn-On Test

At turn-on, the A18 CPU is designed to complete a series of operational checks. If all power supply voltages are present and the A18 CPU is working correctly, the operational checks are completed. Errors are reported if the A18 CPU has problems identifying other assemblies or communicating with the backup memory located on the A31 Motherboard.

### Failure Symptoms

- display is not functioning
- CPU fails to complete the turn-on check and does not reach normal LCD operation
- display is not functioning after turn-on
- unable to control signal generator from front panel
- error message is displayed after turn-on

### A2 Display Not Functioning or A2 Display Not Functioning After Turn-on

Refer to [“Front Panel Display Assembly Troubleshooting”](#) on page 1-11.

### A18 CPU Fails to Complete the Turn-On Check

1. Turn power off and remove outer and inner covers.
2. Turn on power and verify A18 CPU LED DS9 (+3.4 Vdc) and DS10 (+5.2 Vdc) are on. If either of the LEDs are off, check the voltages in [Table 1-2](#).

**Table 1-2**

Connector P222	Supply Voltage	Acceptable Range
Pin 45-48, 95-98	+3.4 Vdc	+3.4 ± 0.07 Vdc
Pin 49, 50, 99, 100	+5.2 Vdc	+5.2 ± 0.1 Vdc

3. If the voltages are present on connector P222, turn power off and remove the A18 CPU.
4. Inspect the pins on the A31 Motherboard connector. If the pins look good replace the A18 CPU.
5. If either of the voltages are missing, refer to [“Power Supply Troubleshooting”](#) on page 1-17.
6. If DS9 and DS10 are on, proceed to [“Checking the A18 CPU Voltages”](#) on page 1-5.

## Checking the A18 CPU Voltages

1. With the external and internal covers removed and the signal generator on its side, turn power on and check to see if all the power supply LEDs on the A31 Motherboard are on. If any of the power supply LEDs are not on, refer to [“Power Supply Troubleshooting” on page 1-17](#) to troubleshoot.
2. If all the power supply LEDs on the motherboard are on, check the A18 CPU and A31 Motherboard connector pins for the voltages listed in the following table.

Connector	Supply Voltage	Acceptable Range
P223-2, 22	+5 VA	+5.2 ± 0.16 Vdc
P223-3	-15 V_In	-15 ± 0.45 Vdc
P223-4	+32 V_In	+32 ± 0.96 Vdc
P223-21	+15 V_Standby	+14.85 ± 0.6 Vdc
P223-23	+15 V_In	+15 ± 0.75 Vdc
P223-37	-7 Vdc	-7.0 ± 0.14 Vdc
P223-39	+10 Vdc	+10.2 ± 0.2 Vdc
P223-40	+8 Vdc	+7.95 ± 0.21 Vdc

3. If any main power supply voltage problems are detected, refer to [“Power Supply Troubleshooting” on page 1-17](#).
4. If all power supply voltages are good, replace A18 CPU.

## Verifying the A18 CPU Turn-On Sequence

Verify the A18 CPU turn-on sequence by observing DS1 to DS8 (located along the top) sequence patterns. DS1 to DS8 should match the sequence shown in [Table 1-3](#). Before verifying the turn-on sequence, make sure all switches in the upper left-hand corner of the A18 CPU are in the CLOSED (up) position. If the lights fail to step through the sequence, replace A18 CPU.

**Table 1-3 A18 CPU LED Sequence Table**

Sequence	DS1	DS2	DS3	DS4	DS5	DS6	DS7	DS8
1	X	X	X	X	X	X	X	X
2	0	0	X	0	0	0	0	0
3	X	X	X	0	0	0	0	0
4	0	X	X	X	X	X	X	X
5	0	0	0	0	0	0	0	0
6	X	X	X	X	X	X	X	0
7	0	0	X	X	0	X	0	X
After Preset	0	0	0	0	0	0	0	0

X = LED is on; 0 = LED is off

## **No Instrument Control From the Front Panel**

Refer to [“Front Panel Display Assembly Troubleshooting”](#) on page 1-11.

### **Error Messages**

If error messages are reported after the turn-on check is completed, refer to the *Error Messages* manual for details.

## Self-Test Failures and Related Troubleshooting

**Table 1-4 Self-test Failures and Related Troubleshooting**

If this self-test fails...	Go to this troubleshooting section...
<p>A13 I/Q Multiplexer</p> <ul style="list-style-type: none"> <li>100 Power Supply</li> <li>101 CAL Source</li> <li>102 Ext In Offset DAC and Switch</li> <li>103 Path 1 &amp; 2 and Ext Out</li> <li>104 Path 1: Attenuators and Summing Amp</li> <li>105 Path 2: Attenuators and Summing Amp</li> <li>106 DC-Couple Mode, CW bias DAC, Course+Fine DAC</li> <li>107 Drift Canceller</li> <li>108 IQ Polarity Switch</li> <li>109 RMS to DC Converter</li> </ul>	<p><a href="#">“Self-Tests 1xx for the A13 I/Q Multiplexer” on page 1-30</a></p>
<p>A5 Sampler</p> <ul style="list-style-type: none"> <li>200 Power Supply</li> <li>201 Tuning + Bias Test</li> <li>202 Coarse Loop Detector</li> <li>203 YO Loop Detector</li> </ul>	<p><a href="#">“Self-Tests 2xx: A5 Sampler Self-Test Errors” on page 1-32</a></p>
<p>A7 Reference</p> <ul style="list-style-type: none"> <li>300 1 GHz Detector</li> <li>301 Tuning Voltage</li> </ul>	<p><a href="#">“Self-Tests 3xx: A7 Reference (Standard) Self-Test Errors” on page 1-34</a></p>
<p>A8 Output</p> <ul style="list-style-type: none"> <li>400 Ground and PTAT Test</li> <li>401 Prelevel Loop Test</li> <li>402 Quadrature DAC Test</li> <li>403 VBLO Test</li> <li>404 Marble Test</li> <li>405 Gain Adjustment Test</li> <li>406 Prelevel Bypass Test</li> <li>407 Switched Filters Test</li> <li>408 (not used)</li> <li>409 ALC Modulation Test</li> <li>410 Burst Modulation Test</li> <li>411 (not used)</li> <li>412 HET Band Test</li> </ul>	<p><a href="#">“Self-Tests 4xx: A8 Output Self-Test Errors” on page 1-35</a></p>

**Table 1-4 Self-test Failures and Related Troubleshooting (Continued)**

If this self-test fails...	Go to this troubleshooting section...
A9 YIG Driver 600 Post Regulator 601 DACs 602 PLL Interface 603 FM Driver 604 Sweep DACs 605 Sweep Lock	<a href="#">“Self-Tests 6xx: A9 YIG Driver Self-Test Errors” on page 1-38</a>
A6 Frac-N 700 Ref Voltage 701 Loop Gain 702 Tuning Voltage 703 Output Voltage 704 Filter Test 705 F/2 Test 706 FM Path Test 707 Sweep Phase Detector Test	<a href="#">“Self-Tests 7xx: A6 Frac-N Self-Test Errors” on page 1-41</a>
A10 ALC 900 Power Supply 901 Detector Test 902 Detector Level to ALC Ref 903 Level Test	<a href="#">“Self-Tests 9xx: A10 ALC Self-Test Errors” on page 1-45</a>
A7 Reference (Option UNR) 1000 Power Supply 1001 10 MHz Test 1002 1 GHz Test	<a href="#">“Self-Tests 10xx: A7 Reference (Option UNR) Self-Test Errors” on page 1-47</a>
A18 CPU 1100 Power Supply	<a href="#">“Self-Tests 11xx: A18 CPU Self-Test Errors” on page 1-49</a>
A26 Micro Interface Deck 1200 Power Supply 1201 Mod Filter 1202 20 GHz Doubler 1203 40 GHz Doubler (Option 540 only) 1204 RF Path 1205 LB Pulse Mod 1206 20 GHz IQ Modulator	<a href="#">“Self-Tests 12xx: A26 MID Self-Test Errors” on page 1-51</a>



**Table 1-4 Self-test Failures and Related Troubleshooting (Continued)**

If this self-test fails...	Go to this troubleshooting section...
<p>A11 Pulse/Analog Modulation Generator</p> <ul style="list-style-type: none"> <li>1300 Power Supply</li> <li>1301 Internal Pulse Generator Clock</li> <li>1302 Output</li> <li>1303 Voltage Ref DAC</li> <li>1304 20 GHz Pulse</li> <li>1305 (not used)</li> <li>1306 Standard 3 GHz Pulse</li> <li>1307 High Performance 3 GHz Pulse</li> <li>1308 Numeric Synthesizer</li> <li>1309 Function Generator Channel 1</li> <li>1310 Function Generator Channel 2</li> <li>1311 Frequency Modulation</li> <li>1312 Low Frequency Out</li> <li>1313 Amplitude Modulation</li> <li>1314 External 1</li> <li>1315 External 2</li> <li>1316 AM Path Loss</li> </ul>	<p><a href="#">“Self-Tests 13xx: A11 Analog/Pulse Modulation Generator Self-Test Errors” on page 1-56</a></p>
<p>A14 Baseband Generator</p> <ul style="list-style-type: none"> <li>1600 Host &lt;-&gt; BBG Comm</li> <li>1601 Apps 1 &lt;-&gt; Apps 2 Comm</li> <li>1602 Apps 1 &lt;-&gt; SH4 Comm</li> <li>1603 Apps 2 &lt;-&gt; SH4 Comm</li> <li>1604 FLiegan &lt;-&gt; Apps 2 Comm</li> <li>1605 SRAM Test</li> <li>1606 SDRAM Test</li> <li>1607 Paren &lt;-&gt; SH4 Comm</li> <li>1608 VCO Tune Test</li> <li>1609 IQ DAC Output</li> <li>1610 PLL Test</li> </ul>	<p><a href="#">“Self-Tests 16xx for the A14 Baseband Generator (Option 002)” on page 1-59</a></p>
<p>A8 Output</p> <ul style="list-style-type: none"> <li>2200 Ground and PTAT Test</li> <li>2201 Prelevel Loop Test</li> <li>2202 Switched Filters Test</li> <li>2203 ALC Mod System Test</li> <li>2204 Pulse Mod System Test</li> <li>2205 RF Path Test</li> </ul>	<p><a href="#">“Self-Tests 22xx: A8 Output Self-Test Errors” on page 1-62</a></p>

## Troubleshooting Assembly-Level Problems

This section provides the following:

- “Front Panel Display Assembly Troubleshooting” on page 1-11
- “Power Supply Troubleshooting” on page 1-17
- “Self-Tests 1xx for the A13 I/Q Multiplexer” on page 1-30
- “Self-Tests 2xx: A5 Sampler Self-Test Errors” on page 1-32
- “Self-Tests 3xx: A7 Reference (Standard) Self-Test Errors” on page 1-34
- “Self-Tests 4xx: A8 Output Self-Test Errors” on page 1-35
- “Self-Tests 6xx: A9 YIG Driver Self-Test Errors” on page 1-38
- “Self-Tests 7xx: A6 Frac-N Self-Test Errors” on page 1-41
- “Self-Tests 9xx: A10 ALC Self-Test Errors” on page 1-45
- “Self-Tests 10xx: A7 Reference (Option UNR) Self-Test Errors” on page 1-47
- “Self-Tests 11xx: A18 CPU Self-Test Errors” on page 1-49
- “Self-Tests 12xx: A26 MID Self-Test Errors” on page 1-51
- “Self-Tests 13xx: A11 Analog/Pulse Modulation Generator Self-Test Errors” on page 1-56
- “Self-Tests 16xx for the A14 Baseband Generator (Option 002)” on page 1-59
- “Self-Tests 22xx: A8 Output Self-Test Errors” on page 1-62

## Front Panel Display Assembly Troubleshooting

### Overview

The Front Panel Display Assembly comprises the following:

- a 640 x 320 pixels liquid crystal display (LCD)
- a power switch/flat panel interface board, which contains the power on/off switch, standby LED, and power-on LED

This board contains the circuitry to disable the power supply: in all models except the E8267C, the ON\_OFF control line is pulled to a TTL *low*; for the E8267C, the logic is reversed, and a TTL *high* disables the power supply.

Another function of the power switch/flat panel interface board is to route the 8 data bits from the A18 CPU to the A2 Display.

- a front panel board that contains the front panel hardkeys, softkeys, and RPG
- a dc to ac inverter, which turns the LCD on and off via control lines received from the CPU

The inverter also converts the 5.2 Vdc to approximately a 160 Vrms, 40 kHz signal to drive the LCD.

**Display Controls Contrast** There are two contrast hardkeys below the A2 Display. The left up arrow key increases the contrast while the right down arrow key decreases the contrast.

**Brightness** The A2 Display brightness can be adjusted from 50 (high brightness) to 1 (low brightness) using the RPG, arrow keys, or the numeric keypad.

Other display features located under the **Utility > Display** softkey, include a screen saver and inverse video.

**Display Tests** The following two screen tests are available for the LCD:

- the Black Pixel Screen Test turns the display dark
- the White Pixel Screen Test turns the display bright

Softkey Location: **Utility > Display > More (1 of 2)**

To exit the test, press any front panel key.

**Symptom: Dark display**

1. Ensure that the front panel green power on LED is on. If not, refer to [“Power Supply Troubleshooting” on page 1-17](#).
2. Press any front panel key to disable the screen saver.
3. If the display is still bad, check P12 on the A31 Motherboard for the following signals:

Signal	State
P12-1	-5.2 Vdc
P12-3 LIGHT_EN	>3 Vdc
P12-4 VDISP	Brightness = 50, VDSP < 50 mV Brightness = 1, VDSP = 3 Vdc

- If the 5.2 Vdc line is bad, refer to [“Power Supply Troubleshooting” on page 1-17](#).
- If either the LIGHT\_EN or VDISP are bad, check them at P221-16 and P221-55 respectively on the A31 Motherboard. If *either* signal is bad at P221, replace the A18 CPU.
- If all the above signals are good, check the output of the dc to ac inverter as follows:
  - a. Remove the front panel from the frame, and lay the front panel face down.
  - b. With CN2-1 open, there is typically a 160 Vrms 40 kHz signal. If not, replace the dc to ac inverter.

If the signal is there, replace the LCD.

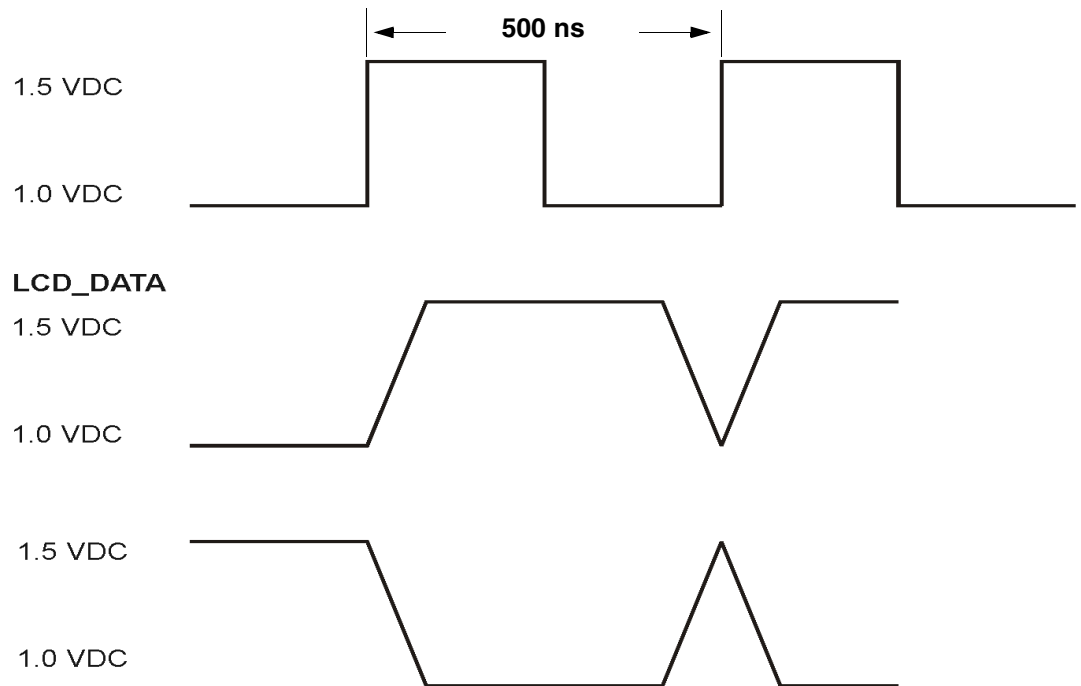
**Symptom: Bright display without characters**

1. Ensure that the front panel green power on LED is on. If not, refer to “Power Supply Troubleshooting” on page 1-17.
2. Try adjusting the contrast controls.
3. Check the connection of the ribbon cable at J9 of the power switch/flat panel interface board.
4. If the display is still too bright, use an oscilloscope to check P11 of the A31 Motherboard for the following signals:

Signal	State
P11-4 VLCD	approximately 21 Vdc
P11-6 LCD_ENABLE_H	>3 Vdc
P11-9, 10, 12, 13, 15, 16, 18, 19, 21, 22, 24, 25, 27, 28, 30, 31, 33, 36, 37, 39, 40	Refer to Figure 1-1.

The pulse state signals are control lines, clock, and data for the LCD.

**Figure 1-1 Pulsing Activity**  
 LCD\_CLK P11-9, P221-50



se991A

5. If *all* the signals measured in Step 4 are good, go to Step 6.

If any of the signals measured in Step 4 are bad, check the following signals at P221 of the motherboard:

Signal	State
P221-14 VLCD	approximately 21 Vdc
P221-53 LCD_ENABLE_H	>3 Vdc
P221-1 to 13, 15, 41, 43, 45, 47, 49 to 52	Refer to <a href="#">Figure 1-1 on page 13</a> .

If any of these signals are bad, change the CPU board.

6. If all the signals measured in Step 4 are good, check the following signals at J9 of the power switch. To access J9 the front panel must be removed from the chassis frame and laid face down.

Signal	State
J9-7 VLCD	approximately 21 Vdc
J9-4 LCD_ENABLE_H	>3 Vdc
J9-5	5.2 Vdc
J9-1, 2, 3, 8 to 15	Refer <a href="#">Figure 1-1 on page 13</a> .

If these signals are good, replace the LCD

If these signals are not good, replace the power switch/flat panel interface board.

## Symptom: Hardkeys or softkeys do not work

The A1 Keyboard contains the hardkeys and softkeys switches. The keys are arranged in a matrix (shown below) with the control lines KEYCOLx and KEYROWx on the x and y axis. When you press a hardkey or softkey, one cell of the matrix is activated; the normally TTL low KEYROWx of the active cell pulses high, and the normally TTL high KEYCOLx of the active cell pulses low.

	KEYCOL0	KEYCOL1	KEYCOL2	KEYCOL3	KEYCOL4	KEYCOL5	KEYCOL6	KEYCOL7
<b>KEYROW0</b>	softkey 3	N/A	Cont Up	N/A	LF Out	N/A	I/Q	Pulse
<b>KEYROW1</b>	softkey 2	Incr/Set	Cont Down	Ampl	Ampl Menu	Mode Setup	Aux Fctn	FM/φM
<b>KEYROW2</b>	softkey 1	Up	N/A	Freq	Sweep List	Mode	Mux	AM
<b>KEYROW3</b>	softkey 4	N/A	N/A	Right Arrow	Help	Save	Recall	Trigger
<b>KEYROW4</b>	softkey 6	N/A	Local	Hold	Mod On/Off	4	5	6
<b>KEYROW5</b>	softkey 5	N/A	Return	Down Arrow	N/A	7	8	9
<b>KEYROW6</b>	N/A	N/A	N/A	Left Arrow	RF On/Off	0	.	+/-
<b>KEYROW7</b>	softkey 7	N/A	Preset	N/A	N/A	1	2	3

1. Ensure that the front panel green power on LED is on. If it is not on, refer to [“Power Supply Troubleshooting” on page 1-17](#).
2. To ensure the signal generator is not being controlled remotely, press the **Local** hardkey.
3. Use an oscilloscope to monitor the KEYCOLx and KEYROWx pins of the key that is not working at P13 on the motherboard. Use the following table to identify the appropriate pin number:

KEYCOL pins should be a TTL high	
KEYCOL0	P13-1
KEYCOL1	P13-3
KEYCOL2	P13-5
KEYCOL3	P13-7
KEYCOL4	P13-9
KEYCOL5	P13-11
KEYCOL6	P13-13
KEYCOL7	P13-15

KEYROW pins should be a TTL low	
KEYROW0	P13-17
KEYROW1	P13-19
KEYROW2	P13-21
KEYROW3	P13-23
KEYROW4	P13-25
KEYROW5	P13-26
KEYROW6	P13-24
KEYROW7	P13-22

4. If *either* signal is incorrect, use the following table and check the signal at P221, as it leaves the CPU board. If the signal is bad at P221, replace the A18 CPU.

KEYCOL pins should be a TTL high	
KEYCOL0	P13-1
KEYCOL1	P13-3
KEYCOL2	P13-5
KEYCOL3	P13-7
KEYCOL4	P13-9
KEYCOL5	P13-11
KEYCOL6	P13-13
KEYCOL7	P13-15

KEYROW pins should be a TTL low	
KEYROW0	P13-17
KEYROW1	P13-19
KEYROW2	P13-21
KEYROW3	P13-23
KEYROW4	P13-25
KEYROW5	P13-26
KEYROW6	P13-24
KEYROW7	P13-22

5. If both signals are correct, press the faulty hardkey or softkey while monitoring the KEYCOL or KEYROW on the oscilloscope. The KEYCOL line should pulse low; the KEYROW line should pulse high.

If *either* line does not function properly, replace the front panel board.

**Symptom: RPG not working properly**

1. Ensure that the front panel green power on LED is on. If it is not on, refer to “[Power Supply Troubleshooting](#)” on page 1-17.
2. Check the front panel operation by checking random hardkey operation.  
When the RPG works properly, DS1 on the CPU board blinks as the RPG knob rotates.
3. Check P13–12 for +5.2 Vdc. If the voltage is not present, refer to “[Power Supply Troubleshooting](#)” on page 1-17 for troubleshooting.
4. Press the Frequency hardkey on the front panel.
5. Using an oscilloscope, monitor P13–14 and P13–10 while rotating the RPG knob. The LCD frequency value should change, and both signals at P13 should pulse to a TTL high. If *either* signal does not pulse, replace the A1 Keyboard.
6. If the signals pulse at P13, check the signal at P221 pins 57 and 17 of the motherboard. If the signals pulse at P221, replace the CPU board.

**Symptom: Screen saver not working properly**

The screen saver delay can be set for any integer from 1 to 12 hours. The CPU board controls the screen saver by pulling the LIGHT\_EN line low.

1. If the delay time elapses and the display does not go dark, check the LIGHT\_EN signal at P12–3.
  - If the signal is a TTL low, replace the dc to ac inverter.
2. If the signal is a TTL high, check it at P221–16 of the motherboard.
  - If the signal is high at P221, replace the CPU board.



## Power Supply Troubleshooting

The power supply is a switching supply, with automatic line-voltage and frequency selection. Because of this, a switch is not required to set 115 VAC or 240 VAC operation. The input power line is fused, but the fuse is not replaceable; if the fuse opens, you must replace the power supply.

---

**WARNING**    **After unplugging the instrument, wait 30 seconds to allow the supplies to discharge before removing or installing an assembly.**

---



---

**NOTE**        Tables 1-5 through 1-7 list the motherboard test points and power supplies for all models *except* the E8267C, Option 520. For this model, see Tables 1-8 through 1-12, which begin on [page 1-20](#).

---

**Table 1-5            Power Supply vs. Assembly Matrix (1 of 3)**

<b>Motherboard test points:</b>	<b>+32 Vdc</b>	<b>+15 Vdc</b>	<b>+10 Vdc</b>	<b>+8 Vdc</b>	<b>+9 Vdc</b>	<b>+5.2 Vdc</b>
A1 Keyboard						P13-2
A2 Display						P11-44
A2DS1 Backlight						
A3 Power Supply	P231-1,41	P231-3, 4, 43, 44	P231-6, 7, 46, 47			P231-15, 18, 19, 55, 56, 58, 59
A5 Sampler	P22-7	P22-6,21			P22-20, 5	P22-14, 29
A6 Frac-N	P32-7	P32-6, 21			P32-20, 5	P32-14, 29
A7 Reference	P42-7	P42-6, 21			P42-20, 5	P42-14, 29
A8 Output	P52-7	P52-6, 21			P52-20, 5	P52-14, 29
A9 YIG Driver	P112-6	P112-5, 30	P112-15, 16, 40		P112-17, 18, 42	P112-3, 28
A10 ALC	P122-4	P122-28				P122-2, 27
A11 Mod Gen	P132-4	P132-28				P132-2, 27
A18 CPU	P223-4	P223-23	P223-39	P223-40	P223-9	P223-2, 22
A21 Rear Panel		P241-13, 14	P241-17, 18			P241-11, 12
Microwave Interface	P201-1	P201-2, 3, 4	P201-5, 6, 7, 8, 9, 10	P201-29		P201-13, 14, 15, 16, 17, 18
Microcircuit test points for:						
AT1		J13-1				
A23 Low Band Coupler/Detector		J15-8				J15-12
A27 40 GHz Doubler		J36-5, J33-5	J36-19 J33-19	J36-21 J33-21		J36-7, 9 J33-7, 9
A29 20 GHz Doubler		J32-5	J32-19	J32-21		J32-7, 9
A30 Mod Filter		J31-5	J31-19	J31-21		J31-7, 9

**Table 1-6 Power Supply vs. Assembly Matrix (2 of 3)**

<b>Motherboard test points:</b>	<b>+5.2 Digital</b>	<b>+3.4 Digital</b>	<b>+2.6 Vdc</b>	<b>-7 Vdc</b>	<b>-6 Vdc</b>
A1 Keyboard					
A2 Display	P12-1				
A2DS1 Backlight	P12-1				
A3 Power Supply	P231-21, 22, 25, 61, 62, 65,	P231-28, 29, 32, 35, 36, 68, 69, 72, 75, 76		P231-9, 10, 49, 50	
A5 Sampler					P22-3, 18
A6 Frac-N					P32-3, 18
A7 Reference					P42-3, 18
A8 Output					P52-3, 18
A9 YIG Driver	P111-64, 65, 129, 130	P111-60, 61, 62, 63, 125, 126, 127, 128	P112-57, 58, 59, 123, 124	P112-11, 12, 13, 14, 38	P112-19, 44
A10 ALC	P122-64, 65, 129, 130	P122, 60, 61, 62, 63, 125, 126, 127, 128	P122-57, 58, 59, 123, 124		
A11 Mod Gen	P132-64, 65, 129, 130	P132-60, 61, 62, 63, 125, 126, 127, 128	P132-57, 58, 59, 123, 124		
A18 CPU	P222-49, 50, 99, 100	P222-45, 46, 47, 48, 95, 96, 97, 98		P223-37	P223-17
A21 Rear Panel					
Microwave Interface	P201-23	P201-24		P201-30, 33, 46	
Microcircuit test points for:					
AT1		J13-2			
A23 Low Band Coupler/Detector					
A27 40 GHz Doubler					
A29 20 GHz Doubler					
A30 Mod Filter					

**Table 1-7 Power Supply vs. Assembly Matrix (3 of 3)**

<b>Motherboard test points:</b>	<b>-15 Vdc</b>	<b>-5.2 Vdc</b>	<b>+12 Vdc</b>	<b>+15 Vdc stby</b>	<b>Fan Voltage</b>
A1 Keyboard					
A2 Display				P11-43	
A2DS1 Backlight					
A3 Power Supply	P231-12, 13,52, 53			P231-80	
A5 Sampler	P22-2	P22-4-19			
A6 Frac-N	P32-2	P32-4,19			
A7 Reference	P42-2	P42-4,19			
A8 Output	P52-2	P52-4,19			
A9 YIG Driver	P112-4,29	P112-1,2,26,27			
A10 ALC	P122-3	P122-1-26			
A11 Mod Gen	P132-3	P132-1, 26			
A18 CPU	P223-3	P223-1		P223-21	
A21 Rear Panel	P241-15, 16	P241-9, 10		P241-5, 6, 7, 8	
Microwave Interface	P201-11,12	P201-31, 32			
Microcircuit test points for:					
AT1					
A23 Low Band Coupler/Detector	J15-10				
A27 40 GHz Doubler	J36-4, J33-4	J36-8, J33-8			
A29 20 GHz Doubler	J32-4	J32-8	J32-1, 3		
A30 Mod Filter	J31-4	J31-8	J31-1, 3		
Fan					P6-2

**Table 1-8 E8267C, Option 520, Power Supply vs. Assembly Matrix (1 of 5)**

<b>Motherboard Test Points:</b>	<b>LED +32 VDC</b>	<b>-24 VREF</b>	<b>LED +15 VDC</b>	<b>+15 VAF</b>	<b>LED +10 VDC</b>	<b>LED + 8 VDC</b>
Power Supply	P231-A4-6		P231-B1-3,D1-3		P233-B1-3,D1-3	
			P232-A4-6			
Sampler	P22-7		P22-6,21			
Frac N	P32-7		P32-6,21			
Reference	P42-7		P42-6,21			
Low Band Output	P52-7		P52-6,21			
YTO Driver	P112-6		P112-5,30		P112-15,16,40	
ALC/Scan	P122-4		P122-28			
Mod Gen	P132-4		P132-28			
CPU	P223-4		P223-23		P223-39	P223-40
I/Q Multiplexer	P152-4		P152-28			
Baseband Generator	P162-4		P162-28			
Microwave Interface	P201-1		P201-2,3,4		P201-5,6,7,8,9,10	P201-29 <sup>a</sup>
20 GHz Doubler			J32-5		J32-19	J32-21
20 GHz Mod Filter			J31-5		J31-19	J31-21
20 GHz I/Q Modulator		J34-8 <sup>a</sup>		J34-3 <sup>a</sup>		
40 GHz Doubler			J36-5, J33-5		J36-19,J33-19	J36-21,J33-21
Attenuator			J13-1			
Lowband Coupler/Det			J15-8			
Rear Panel			P241-13,14		P241-17,18	
Fan						

a. Originates on microwave interface.

**Table 1-9 E8267C, Option 520, Power Supply vs. Assembly Matrix (2 of 5)**

<b>Motherboard Test Points:</b>	<b>+8 VA</b>	<b>LED + 9 VDC</b>	<b>LED + 5.2 VDC</b>	<b>+5.2 VAF</b>	<b>LED + 5.2D</b>	<b>+5.2 VDF</b>
Power Supply			P232-B1-3,C4-6,D1-3		P236-B1-3,D1-3	
Sampler		P22-20,5	P22-14,29			
Frac N		P32-20,5	P32-14,29			
Reference		P42-20,5	P42-14,29			
Low Band Output		P52-20,5	P52-14,29			
YTO Driver		P112-17,18,42 <sup>a</sup>	P112-3,28		P111-64,65,129,130	
ALC/Scan			P122-2,27		P122-64,65,129,130	
Mod Gen			P132-2,27		P132-64,65,129,130	
CPU		P223-18	P223-2,22		P222-49,50,99,100	
I/Q Multiplexer			P152-2,27		P151-64,65,129,130	
Baseband Generator			P162-2,27		P161-64,65,129,130	
Microwave Interface			P201-13,14,15,16, 17,18		P201-23	
20 GHz Doubler			J32-7,9			
20 GHz Mod Filter			J31-7,9			
20 GHz I/Q Modulator	J34-5,6 <sup>b</sup>			J34-7 <sup>b</sup>		J34-28 <sup>b</sup>
40 GHz Doubler			J36-7,9, J33-7,9			
Attenuator					J13-2	
Lowband Coupler/Det			J15-12			
Front Panel/Display			P11-44			
Keyboard			P13-2			
Display Backlight					P12-1	
1E5 OCXO						
Rear Panel			P241-11,12			
Fan						

- a. Originates on YTO Driver
- b. Originates on microwave interface

**Table 1-10 E8267C, Option 520, Power Supply vs. Assembly Matrix (3 of 5)**

<b>Motherboard Test Points:</b>	<b>LED + 3.4D</b>	<b>LED + 2.6VD</b>	<b>LED -7 VDC</b>	<b>LED -6 VDC</b>	<b>LED -15 VDC</b>	<b>-15 VAF</b>
Power Supply	P236-A4-6, C4-6,E4-6 P237-A4-6,B1-3, C4-6,D1-3	P238-A4-6, B1-3,E4-6 P239-A4-6,B1-3	P233-A4-6,C4-6,E4-6		P231-C4-6, E4-6	
Sampler				P22-3,18	P22-2	
Frac N				P32-3,18	P32-2	
Reference				P42-3,18	P42-2	
Low Band Output				P52-3,18	P52-2	
YTO Driver	P111-60,61,62,63, 125,126,127,128	P112-57,58,59, 123,124	P112-11,12,13,14,38	P112-19,44 <sup>a</sup>	P112-4,29	
ALC/Scan	P122-60,61,62,63, 125,126,127,128	P122-57,58,59, 123,124			P122-3	
Mod Gen	P132-60,61,62,63, 125,126,127,128	P132-57,58,5, 123,124			P132-3	
CPU	P222-45,46,47,48, 95,96,97,98		P223-37	P223-17	P223-3	
I/Q Multiplexer	P151-60,61,62,63, 125,126, 127,128	P151-57,58,59, 123,124			P152-3	
Baseband Generator	P161-60,61,62,63, 125,126, 127,128	P161-57, 58,59, 123,124			P162-3	
Microwave Interface	P201-24		P201-30,33,46		P201-11,12	
20 GHz Doubler					J32-4	
20 GHz Mod Filter					J31-4	
20 GHz I/Q Modulator						J34-4 <sup>b</sup>
40 GHz Doubler					J36-4, J33-4	
Lowband Coupler/Det					J15-10	
Rear Panel					P241-15,16	

- a. Originates on YTO driver
- b. Originates on Microwave Interface

**Table 1-11 E8267C, Option 520, Power Supply vs. Assembly Matrix (4 of 5)**

<b>Motherboard Test Points:</b>	<b>LED -5.2V</b>	<b>LED -5.2 V2<sup>a</sup></b>	<b>+ 12 VDC</b>	<b>LED + 15 VSTBY</b>	<b>Fan Voltage</b>
Power Supply				P235-E4,5	
Sampler	P22-4,19				
Frac N	P32-4,19				
Reference	P42-4,19				
Low Band Output	P52-4,19				
YTO Driver	P112-1,2,26,27 <sup>b</sup>				
ALC/Scan	P122-1,26				
Mod Gen	P132-1,26				
CPU		P223-1		P223-21	
I/Q Multiplexer	P152-1	P152-26			
Baseband Generator	P162-1	P162-26			
Microwave Interface	P201-31,32				
20 GHz Doubler	J32-8		J32-1,3 <sup>c</sup>		
20 GHz Mod Filter	J31-8		J31-1,3 <sup>c</sup>		
20 GHz I/Q Modulator			J34-9 <sup>c</sup>		
40 GHz Doubler	J36-8, J33-8				
Attenuator					
Lowband Coupler/Det					
Front Panel/Display				P11-43	
Keyboard					
Display Backlight					
1E5 OCXO					
Rear Panel		P241-9,10		P241-5,6,7,8	
Fan					Fan+ P252-2, P251-2 Fan- P252-1, P251-1

- a. Voltage regulator on motherboard
- b. Originates on YTO Driver
- c. Originates on Microwave Interface

**Table 1-12 E8267C, Option 520, Power Supply vs. Assembly Matrix (5 of 5)**

<b>Motherboard Test Points:</b>	<b>LED +1.95VD1<sup>a</sup></b>	<b>LED +1.8VD_1<sup>a</sup></b>
Baseband Generator	P161-52,118	P161-55,56,120-122

- a. Voltage regulator on motherboard

**NOTE** For all models *except* the E8267C, Option 520, use the [Power Supply vs. Assembly Matrix](#) tables 1-5 through 1-7, which begin on [page 1-17](#).

For the E8267C, Option 520, use the [Power Supply vs. Assembly Matrix](#) tables 1-8 through 1-12, which begin on [page 1-20](#).

---

**Symptom: amber standby LED not working properly**

With the instrument plugged in and the power turned off, the front panel amber standby LED should be on, as well as the green +15 Standby LED on the motherboard. This is controlled by the +15 Standby line supplied by the power supply, which is routed via the motherboard to the front panel.

To troubleshoot, turn the instrument off and follow the signal path.

**Symptom: front-panel green LED not working properly**

When the front panel power switch is turned on, the amber LED should go out and the green LED should come on. Also, the fan should start rotating and the front panel display should illuminate.

Troubleshooting:

- For all models *except* the E8267C, verify the supply voltages at P11 of the A31 Motherboard.
- For the E8267C, verify the supply voltages at P231 through P238 of the A31 Motherboard.

If the supply voltages are correct, replace the Power Switch/Flat Panel Interface Board.

**Symptom: fan not working**

The fan is connected to the rear panel assembly, and is audible when the instrument is on. The fan voltage is variable, and dependent on temperature. At room temperature, the fan races at first, and then stabilizes at a fan voltage of approximately +8.5V (at 23°C). At higher temperatures, the voltage increases to +14V (at 55°C), and the fan speed increases.

To troubleshoot, verify that all supplies are working; disconnect the fan from the rear panel assembly at P6 and check the fan voltage at P6-2. If the fan voltage is correct, replace the fan.



**Symptom: Instrument does not power up; power supply LEDs not on**

**Checking Power Supplies** Each of the power supplies has an LED on the bottom of the motherboard (see [Figure 1-2 on page 26](#) and [Figure 1-3 on page 27](#)). When the power supply is functioning, the green LED lights. Use a DVM to measure the supplies on the motherboard, and ensure they meet the following power supply specifications.

Supply Voltage	Acceptable Voltage (Vdc)	Maximum Ripple (mVpp)
+32	$32 \pm 0.96$	10
+15	$15 \pm 0.45$	10
+15 Standby	$15 \pm 0.45$	20
+10	$10 \pm 0.3$	10
+5.2	$5.2 \pm 0.16$	10
+5.2 D	$5.2 \pm 0.16$	20
+3.4 D	$3.4 \pm 0.1$	10
+2.6 D	$2.6 \pm 0.08$	10

Supply Voltage	Acceptable Voltage (Vdc)	Maximum Ripple (mVpp)
+1.95 VD_1	$1.95 \pm 0.06$	10
+1.95 VD_2	$1.95 \pm 0.06$	10
+1.8 VD_1	$1.8 \pm 0.05$	10
+1.8 VD_2	$1.8 \pm 0.05$	10
-5.2 V2	$-5.2 \pm 0.16$	10
-7.0	$-7.0 \pm 0.21$	10
-15	$-15 \pm 0.45$	10

If a supply LED is not lit, or a measured voltage is less than the acceptable value, an assembly may be loading down that supply. Using the appropriate [Power Supply vs. Assembly Matrix](#), determine where each supply is used, then use the following steps to isolate the defective assembly.

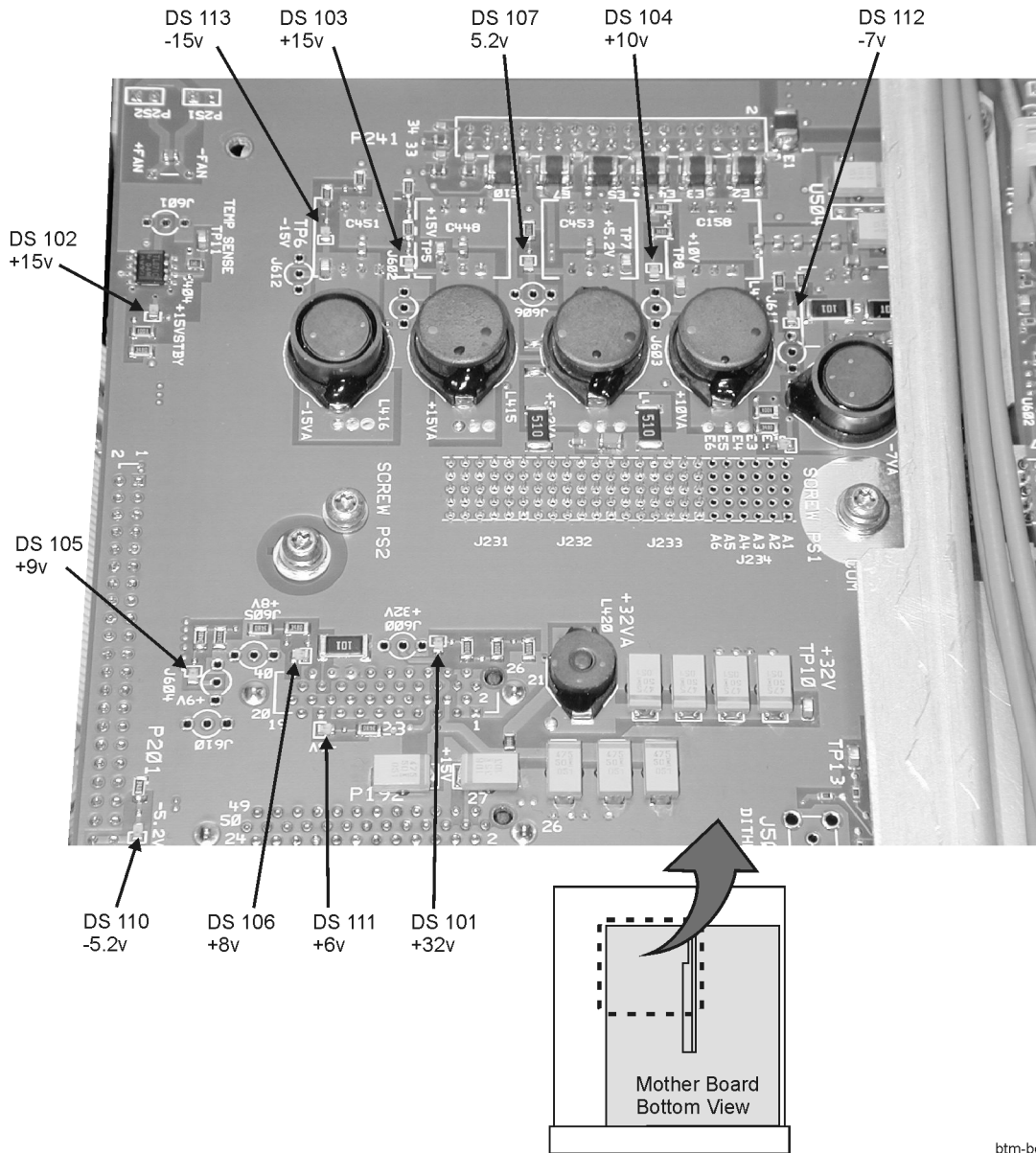
---

**CAUTION** Remove a *minimum* number of assemblies at one time. If the power supply does not have a minimum load on it, the supply voltage increases to an overvoltage condition.

---

1. Turn off the instrument and remove one of the assemblies biased by the faulty supply.
2. Turn the instrument on and check the faulty supply. If the supply LED lights, replace the assembly removed in Step 1. If not, continue with Step 3.
3. Turn the instrument off and reinstall the assembly removed in Step 1. Remove the next assembly and see if the supply LED lights. Continue this process until the supply functions properly.
4. Replace the last assembly that you removed.

**Figure 1-2 Motherboard Power Supply LEDs (1 of 2)**

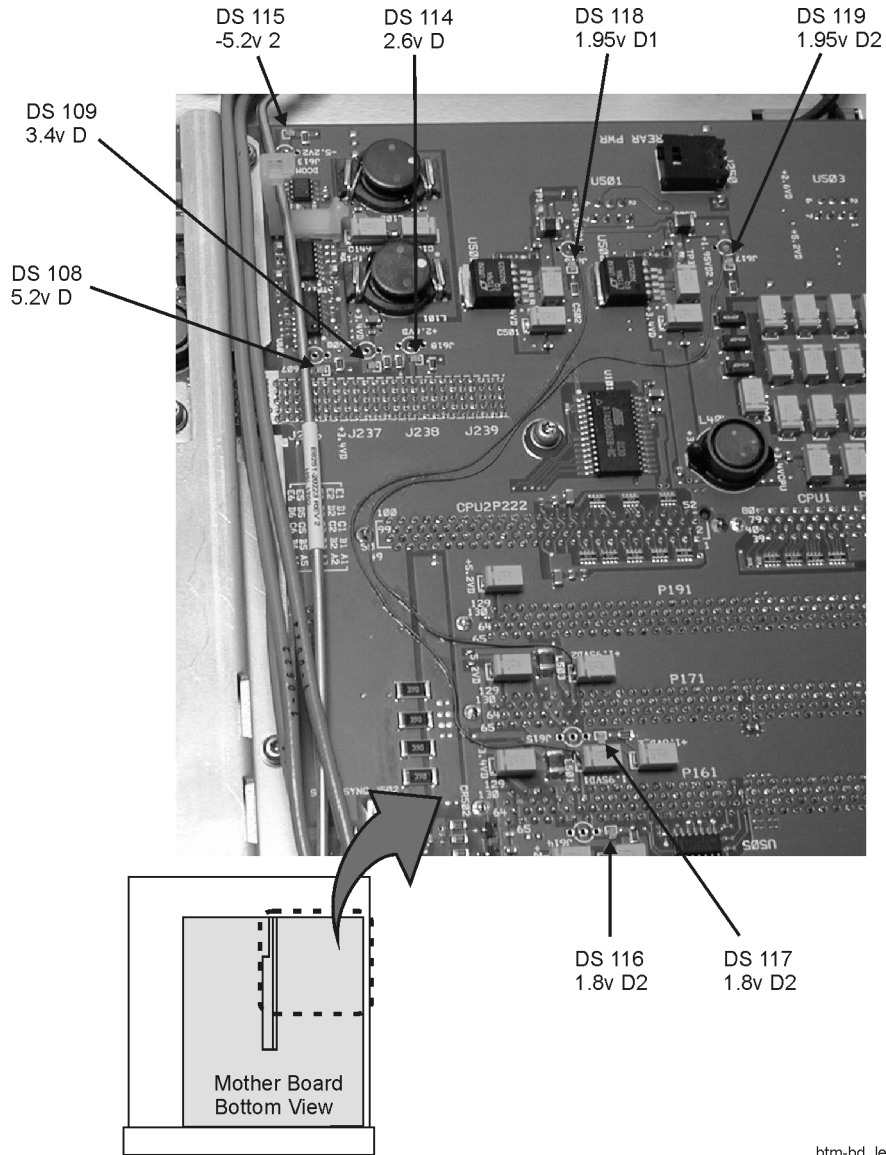


btm-bd\_led\_1

**Power Switch On/Off Line** For all models except the E8267C, if the control line (ON/OFF) from the A3 Power Switch located in the front panel assembly goes to a TTL low state, or if the line impedance is less than 500 ohms, the power supply shuts down. This signal can be measured on the A31 Motherboard at pin 79 of P241.

For the E8267C, if the control line (ON\_OFF) from the A3 Power Switch located in the front panel assembly goes to a TTL high state or open, the power supply shuts down. The signal can be measured on the A31 Motherboard at pin 67 of P221.

**Figure 1-3**      **Motherboard Power Supply LEDs (2 of 2)**



btm-bd\_led\_2

To troubleshoot:

1. Turn the front panel switch on and ensure that the +15 Standby is good.
2. For all models except the E8267C, the ON/OFF control line should be > 3.5 Vdc.

For the E8267C, the ON\_OFF control line should be < 3.5 Vdc.

The Power Switch/Flat-Panel Interface Board in the front panel assembly controls this signal.

**Symptom: Green front panel LED and power supply LEDs on motherboard blinking**

**Overvoltage or Overcurrent** The individual supplies in the instrument are not fused, but an overvoltage or overcurrent condition can shut them down. With either of these conditions, the front panel green LED and the power supply LEDs blink at approximately 2 Hz. The power supply tries to revive, but if the condition does not clear, the instrument stays in this mode. In some cases, cycling power fixes the problem.

To troubleshoot, use the following steps to isolate the defective assembly:

---

**CAUTION** Remove a *minimum* number of assemblies at one time. If the power supply does not have a minimum load on it, the supply voltage increases to an overvoltage condition.

---

1. Turn off the instrument and remove one of the assemblies biased by the faulty supply.
2. Turn the instrument on and check whether the overvoltage or overcurrent condition still exists. If it does not, replace the assembly removed in Step 1. If it does, continue with Step 3.
3. Turn the instrument off and reinstall the assembly removed in Step 1. Remove the next assembly and see if that fixes the problem. Continue this process until the supply functions properly.
4. Replace the last assembly that you removed.

**Thermal shutdown** With thermal shutdown, the front panel green LED and the power supply LEDs blink as long as the condition exists. There are two temperature sensing devices in the instrument: one on the A8 Output, and one on the A19 Power Supply.

To troubleshoot:

1. If the instrument is hot, ensure that the fan is working and let the instrument cool off.
2. If the instrument still shuts down, remove the Output assembly.
3. If the instrument still shuts down, replace the power supply.

**Symptom; +9, -6, or -5.2 V LEDs not on**

These supplies are generated on the YIG Driver Assembly.

Troubleshoot using the [Power Supply vs. Assembly Matrix](#) that begins on [page 1-17](#).

1. At P112 of the Motherboard, ensure the YIG Driver Assembly is receiving the +32, +15, +10, -7, -15 Vdc supplies.
2. If the supplies are present at P112, note in the matrix where each supply is used.
3. Power down the instrument and remove one of the assemblies that is biased by the faulty supply.
4. Power the instrument up again and check the faulty supply. If it is still bad, power down and re-install the first assembly removed.
5. Remove the next assembly and see if that fixes the problem. Continue this process until the supply functions properly.
6. Replace the last assembly that you removed.

**Symptom: -5.2 V2, +1.95 VD, +1.8 VD LEDs not on**

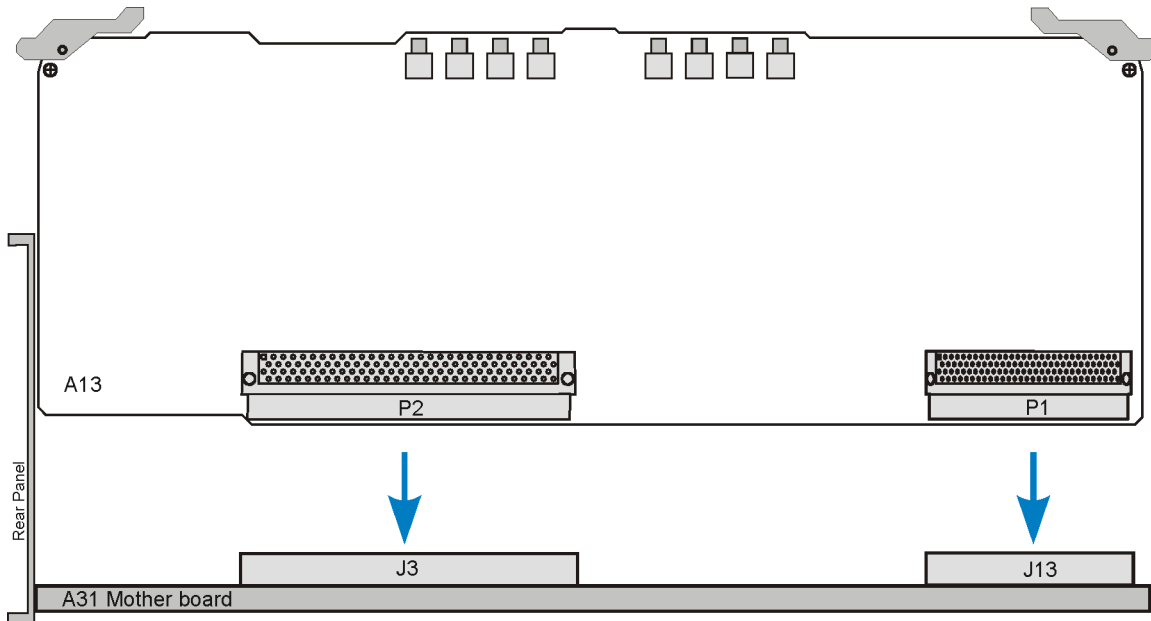
These supplies are generated by voltage regulators on the A31 Motherboard.

Troubleshoot by checking the following voltages at the A19 Power Supply:

- -7V, which is regulated down to -5.2 V2
- +3.4 VD, which is regulated down to +1.95 VD
- +2.6 VD, which is regulated down to +1.8 VD

If the supplies are good at the A19 Power Supply, replace the A31 Motherboard

## Self-Tests 1xx for the A13 I/Q Multiplexer



Power Supply Voltage (Vdc)	A31 Motherboard Connector Pins	Minimum (Vdc)	Maximum (Vdc)	Origin
+15	P152 – 28	+14.55	+15.45	Main Supply
-15	P152 – 3	-15.45	-14.55	Main Supply
+5.2	P152 – 5, 27	+5.04	+5.36	Main Supply
-5.2	P152 – 1	-5.36	-5.04	A9 YIG Driver
-5.2 V2	P152 – 26	-5.36	-5.04	A31 Motherboard
+5.2 D	P151 – 64, 65, 129, 130	+5.04	+5.36	Main Supply

### 100 Power Supply

- If all power supply voltages are good on the A31 Motherboard, replace the A13 I/Q Multiplexer.
- If any of the supply voltages are bad on the A31 Motherboard, check the origin of that supply.
  - If the supply voltage is good at the origin, replace the A31 Motherboard.
  - If the supply voltage is bad at the origin, troubleshoot the origin.

### 101 CAL Source

- Replace the A13 I/Q Multiplexer.

**102 Ext In Offset DAC and Switch**

- Replace the A13 I/Q Multiplexer

**103 Path 1 & 2 and Ext Out**

- Replace the A13 I/Q Multiplexer

**104 Path 1: Attenuators and Summing Amp**

- Replace the A13 I/Q Multiplexer

**105 Path 2: Attenuators and Summing Amp**

- Replace the A13 I/Q Multiplexer

**106 DC-Couple Mode, CW bias DAC, Course+Fine DAC**

- Replace the A13 I/Q Multiplexer

**107 Drift Canceller**

- Replace the A13 I/Q Multiplexer

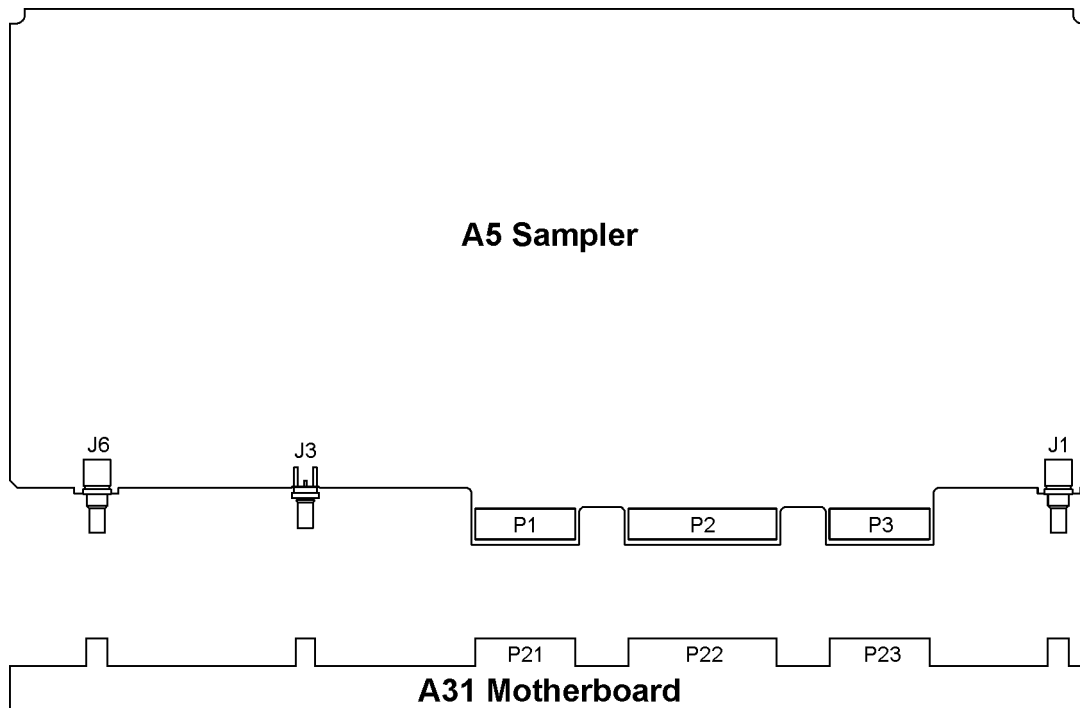
**108 IQ Polarity Switch**

- Replace the A13 I/Q Multiplexer

**109 RMS to DC Converter**

- Replace the A13 I/Q Multiplexer.

## Self-Tests 2xx: A5 Sampler Self-Test Errors



Before proceeding to the reported self-test error code, check the following voltages. If any voltages are out of specification troubleshoot the supply problem first.

Supply Voltage (Vdc)	Connector Pins	Minimum Value (Vdc)	Maximum Value (Vdc)	Origin
+32	P22-7	+31.04	+32.96	Main Supply
+15	P22-6, 21	+14.55	+15.45	Main Supply
-15	P22-2, 17	-14.55	-15.45	Main Supply
+5.2	P22-14, 29	+5.04	+5.37	Main Supply
+9	P22-5, 20	+8.82	+9.18	YIG Driver

### 200 Power Supply

1. If the supply voltages are good on the connector pins indicated, replace the A5 Sampler.
2. If the supply voltages are bad on any of the connector pins indicated, check the origin of the supply.
3. If the supply voltages are good at the origin, replace the A31 Motherboard.
4. If the supply voltages are bad at the origin, troubleshoot the problem using that assembly's troubleshooting procedure.



### 201 Tuning + Bias Test

1. Turn power off and remove the A5 Sampler and connect a signal analyzer to the A5 Sampler J1 input cable on the A31 Motherboard.
2. Turn the signal generator on and check for the presence of a 1 GHz signal at the level of 0 dBm.
3. If the signal is good on the cable connector J1, replace the A5 Sampler.
4. If the signal is bad, remove the A7 Reference and ohm the cable between the center pins (a short should occur) and between the center pins and shielding (an open should occur) of J3 on the A7 Reference and J1 on the A5 Sampler.
5. If an open is measured between the center pins or a short between center pins and the shielding, replace the cable.
6. If the cable is good, replace the A7 Reference.

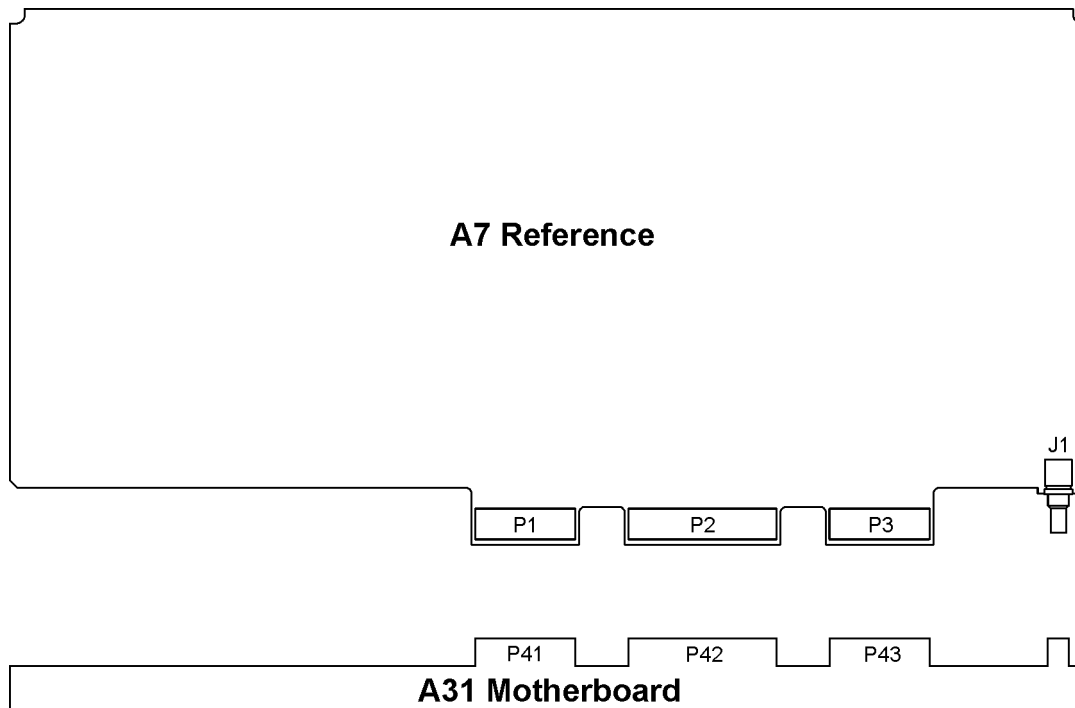
### 202 Coarse Loop Detector

1. Replace the A5 Sampler

### 203 YO Loop Detector

1. With power on carefully remove the A5 Sampler, connect a signal analyzer to J3 on the A31 Motherboard. Set the signal generator to 8 GHz CW then check for an 8 GHz signal at a power level greater than or equal to  $-7$  dBm on J3.
2. If the J3 signal is bad, troubleshoot the A29 20 GHz Doubler using the procedure in the RF path section. If the J3 signal is good, go to the next step.
3. Connect the signal analyzer to the A6 Frac-N VCO signal on the J6 connection on the A31 Motherboard. With the signal generator set to 8 GHz CW, the A6 Frac-N signal should be at a frequency of 593.75 MHz and at a power level of  $+7$  dBm.
4. If the signal is good, replace the A5 Sampler, if the signal is bad go to the A6 Frac-N troubleshooting procedure.

## Self-Tests 3xx: A7 Reference (Standard) Self-Test Errors



Before proceeding to the reported self-test error code, check the following voltages. If any of the voltages are out of specification troubleshoot the supply problem first.

Supply Voltage (Vdc)	Connector Pins	Minimum Value (Vdc)	Maximum Value (Vdc)	Origin
+32	P102-7	+31.04	+32.96	Main Supply
+15	P102-6, 21	+14.55	+15.45	Main Supply
-15	P102-2, 17	-14.55	-15.45	Main Supply
+5.2	P102-14, 29	+5.04	+5.37	Main Supply
+9	P102-5, 20	+8.82	+9.18	YIG Driver

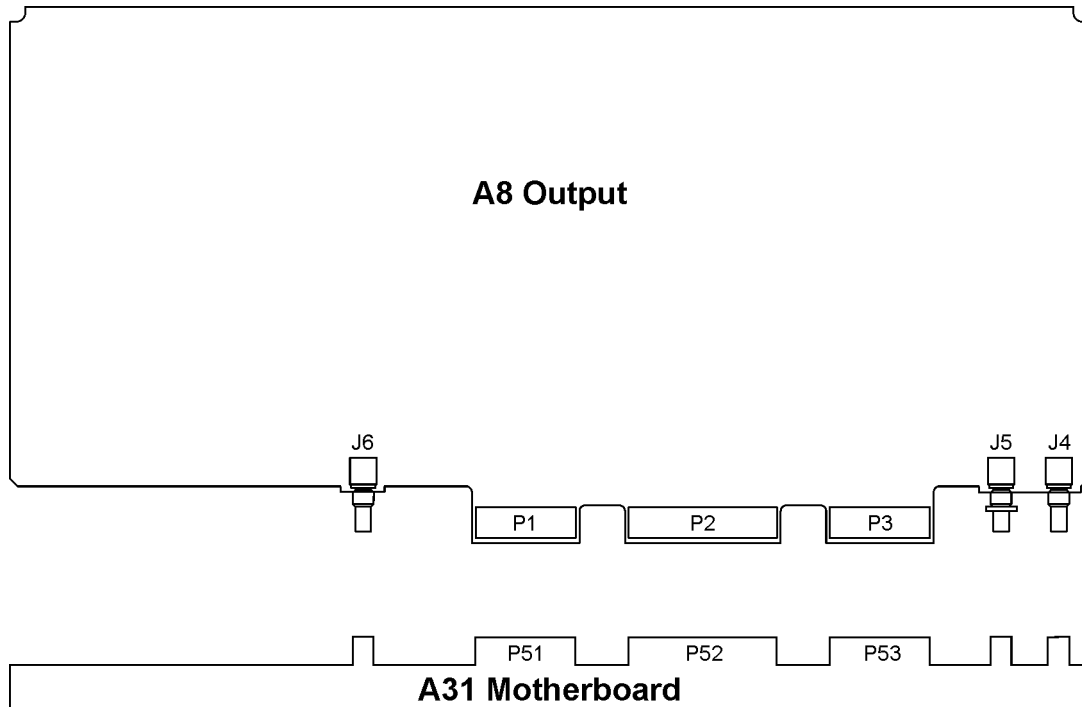
### 300 1 GHz Detector

1. Check and remove any connection to the 10 MHz external reference on the rear panel.
2. If the signal generator continues to fail self-test, replace the A7 Reference.

### 301 Tuning Voltage

1. Replace the A7 Reference.

## Self-Tests 4xx: A8 Output Self-Test Errors



**Before proceeding to the reported self-test error code, check the following voltages. If any voltages are out of specification troubleshoot the supply problem first.**

Supply Voltage (Vdc)	Connector Pins	Minimum Value (Vdc)	Maximum Value (Vdc)	Origin
+15	P52-6, 21	+14.55	+15.45	Main Supply
-15	P52-2, 17	-15.45	-14.55	Main Supply
+5.2	P52-14, 29	+5.04	+5.36	Main Supply
+9	P52-5, 20	+8.82	+9.18	YIG Driver
-6	P52-3, 18	-6.12	-5.88	YIG Driver

### 400 Lowband Ground and PTAT Test

- Replace A8 Output.

#### 401 Prelevel Loop Test

1. With the signal generator powered up, carefully remove the A8 Output.
2. Set the signal generator to 3 GHz CW.
3. Using a spectrum analyzer measure the A6 Frac-N RF output at J4 of the A8 Output.  
The signal at J4 should be at 3 GHz and  $\geq 0$  dBm.
  - If the signal is not present, or is not at the correct level, replace the Frac-N.
  - If the signal is present, replace the A8 Output.

---

**WARNING** Do not re-install the A8 Output with the signal generator turned on, or serious damage to the signal generator can result.

---

#### 402 Quadrature DAC Test

- Replace the A8 Output.

#### 403 VBLO Test

- Replace the A8 Output.

#### 404 Marble Test

1. Measure the Q signal from the A13 I/Q Multiplexer:
  - a. Disconnect the cable from J1052 A31 Motherboard and connect it to a DVM.
  - b. Set the CW frequency to 2 GHz.
  - c. Turn on the I/Q modulation, and make the Q offset the active function:
    1. Press the **I/Q** hardkey.
    2. Select **I/Q On > I/Q Adjustments > I/Q Adjustments On > Q Offset**
  - d. As you rotate the RPG, the voltage displayed on the DVM should vary from approximately +0.25 Vdc for an offset of 50%, to approximately -0.25 Vdc for an offset of -50%.  
If the signal is bad, check it at J10 of the A13 I/Q Multiplexer.
    - If the signal is bad at J10, refer to the A13 I/Q Multiplexer troubleshooting, [on page 1-30](#).
    - If the signal is good at J10, change the cable.
2. Measure the I signal from the A13 I/Q Multiplexer:
  - a. Reconnect the cable removed in [Step 1](#).
  - b. Disconnect the cable from J1053 A31 Motherboard and connect it to the DVM.
  - c. Leave the I/Q modulation on, and make the I offset the active function.
  - d. As you rotate the RPG, the voltage displayed on the DVM should vary from approximately +0.25 Vdc for an offset of 50%, to approximately -0.25 Vdc for an offset of -50%.  
If the signal is bad, check it at J9 of the A13 I/Q Multiplexer.
    - If the signal is bad at J9, refer to the A13 I/Q Multiplexer troubleshooting, [on page 1-30](#).
    - If the signal is good at J9, change the cable.

3. If both the I and Q signals are good, reconnect the cable removed in [Step 2](#). Check the signals at the A8 Output board.
  - a. At J53-8, repeat the Q offset check in [Step 1](#).
    - If the signal is good, replace the A8 Output board.
    - If the signal is bad, replace the A31 Motherboard.
  - b. At J53-19, repeat the I offset check in [Step 2](#).
    - If the signal is good, replace the A8 Output board.
    - If the signal is bad, replace the A31 Motherboard.

#### **405 Gain Adjustment Test**

- Replace the A8 Output.

#### **406 Prelevel Bypass Test**

- Replace the A8 Output.

#### **407 Switched Filters Test**

- Replace the A8 Output.

#### **408 ALC Reference DAC Test**

- Replace the A8 Output.

#### **409 ALC Modulation Test**

- Replace the A8 Output.

#### **410 Burst Mod Driver Test**

- Replace the A8 Output.

#### **411 ALC Detector Test**

- Replace the A8 Output.

#### **412 Het Band Test**

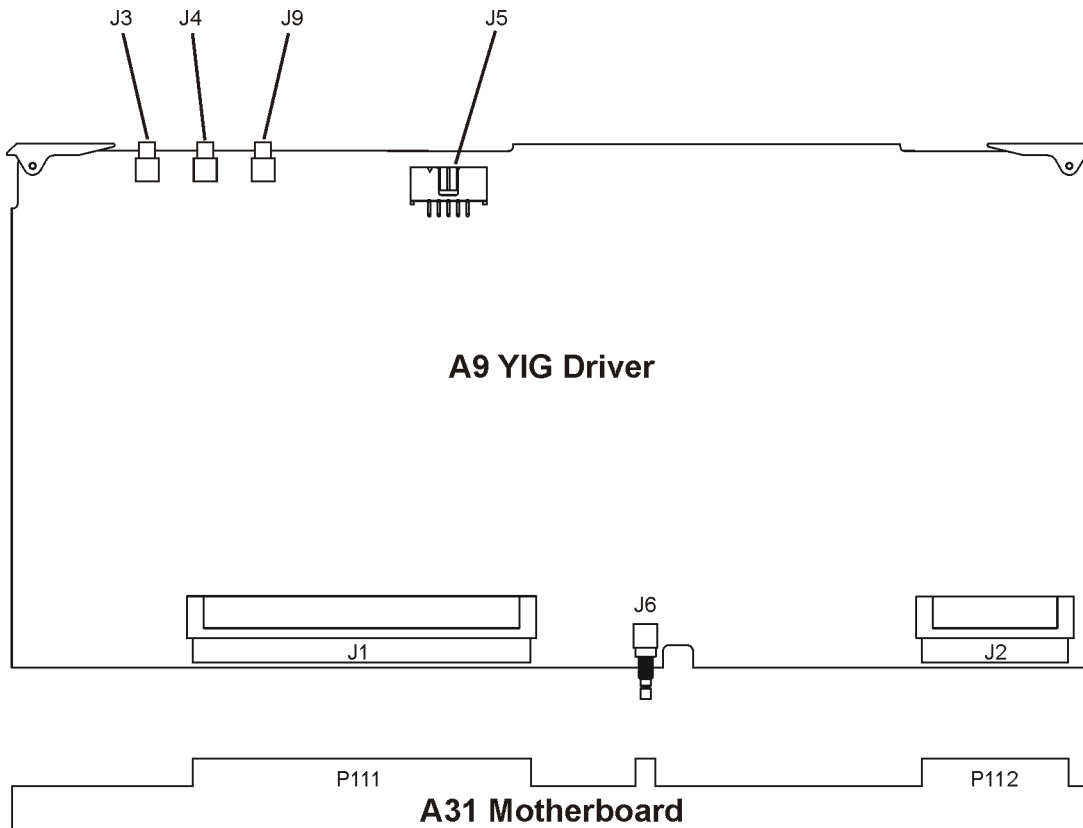
Measure the 1 GHz signal from the A7 Reference board:

1. Turn on the signal generator.
2. Set CW = 200 MHz.
3. Using a spectrum analyzer, probe P51-19.

There should be a 1 GHz signal, that is  $>-30$  dBm.

- If the signal is good, replace the A9 Output.
- If the signal is not good, run the A7 self-tests.

### Self-Tests 6xx: A9 YIG Driver Self-Test Errors



Before proceeding to the reported self-test error code, check the following voltages. If any are out of specification, troubleshoot the supply problem first.

Supply Voltage (Vdc)	Connector Pins	Minimum Value (Vdc)	Maximum Value (Vdc)	Origin
+32	P112-6	+31.04	+32.96	Main Supply
+15	P112-5, 30	+14.55	+15.45	Main Supply
-15	P112-4, 29	-14.55	-15.45	Main Supply
+5.2	P112-3, 28	+5.04	+5.37	Main Supply
+10	P112-15, 16, 40	+10	+10.4	Main Supply
-7	P112-11, 12, 13, 14, 38	-6.86	-7.14	Main Supply
+5.2 Digital high	P111-64, 65, 129, 130	+5.04	+5.36	Main Supply
+3.4 Digital Low	P111-60, 61, 62, 63, 125, 126, 127, 128	+3.29	+3.5	Main Supply

### A9 YIG Driver Output Voltages

If any of the following voltages are out of specification, replace the A9 YIG Driver:

Supply Voltage (Vdc)	Connector Pins	Minimum Value (Vdc)	Maximum Value (Vdc)
+9	P112-17, 18, 42	+8.82	+9.18
-5.2	P112-1, 2, 26, 27	-5.1	-5.3
-6	P112-19, 44	-5.88	-6.12

### 600 Post Regulator

- Replace the A9 YIG Driver.

### 601 DACs

- Replace the A9 YIG Driver.

### 602 PLL Interface

1. Remove the cable that goes from the A5 Sampler to J4 on the A9 YIG Driver.
2. Loop self-test 602, and use an oscilloscope to measure the voltage on J4. The voltage should pulse to +10 Vdc.
  - If the voltage is +10 Vdc, replace the A9 YIG Driver.
  - If the voltage on J4 is bad, replace the A5 Sampler.

### 603 FM Driver

1. Remove the cable that goes from the A6 Frac-N to J3 on the A9 YIG Driver.
2. Loop self-test 603, and use an oscilloscope to measure the voltage on J3. The voltage should be approximately -1.3 Vdc.
  - If the voltage is approximately -1.3 Vdc, replace the A9 YIG Driver.
3. If the voltage is bad at J3, check it entering the A6 Frac-N at P31-11.

The voltage on J3 originates on the A11 Pulse/Analog Modulation Generator and passes through the A6 Frac-N.

- If the voltage is good entering the A6 Frac-N, troubleshoot the Frac-N.
- If the voltage is bad at P31, troubleshoot the A11 Pulse/Analog Modulation Generator.

### 604 Sweep DACs

- Replace the A9 YIG Driver.

### 605 Sweep Lock

1. Using an oscilloscope with high input impedance, measure the center pin of A9J9.

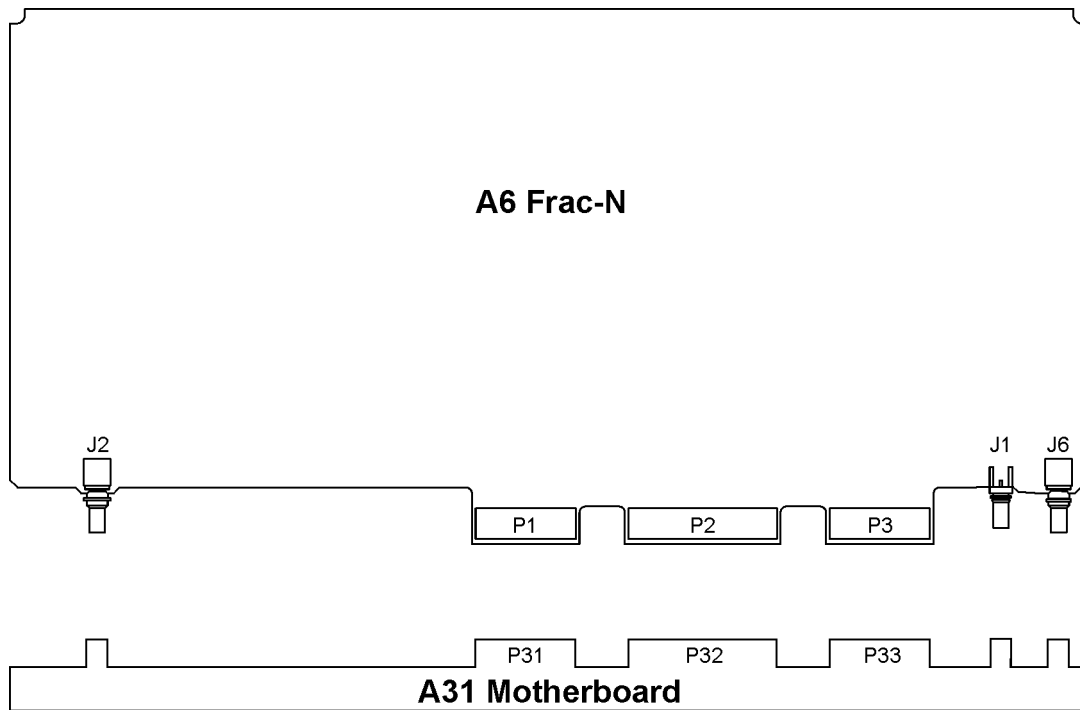
Source Setup		Oscilloscope Setup
Start:	5 GHz	10 ms/div
Stop:	10 GHz	5V/div
Sweep:	Freq	1 MΩ
Sweep Time:	Auto	
Sweep Repeat:	Continuo us	

A positive and negative going signal should be present.

- If the signal is present at A9J9, replace the A9 YIG Driver.
2. If the signal is not present at A9J9, measure the center pin of J1032 on the motherboard.
    - If the signal is present, replace the cable.
    - If the signal is not present, replace the A6 Frac-N.



## Self-Tests 7xx: A6 Frac-N Self-Test Errors



Before proceeding to the reported self-test error code, check the following voltages. If any voltages are out of specification troubleshoot the supply problem first.

Supply Voltage (Vdc)	Connector Pins	Minimum Value (Vdc)	Maximum Value (Vdc)	Origin
+32	P32-7	+31.04	+32.96	Main Supply
+15	P32-6, 21	+14.55	+15.45	Main Supply
-15	P32-2, 17	-14.55	-15.45	Main Supply
+5.2	P32-14, 29	+5.04	+5.37	Main Supply
+9	P32-5, 20	+8.82	+9.18	YIG Driver
-5.2	P32-4, 19	-5.1	-5.3	YIG Driver
-6	P32-3, 18	-5.88	-6.12	YIG Driver

### 700 Ref Voltage

- Replace the A6 Frac-N.

### 701 Loop Gain

- Replace the A6 Frac-N.

### 702 Tuning Voltage

1. Using an oscilloscope, check 10 MHz Synthesis line on P33–15. The signal period should be 100 ns with an amplitude of approximately  $3V_{pp}$ .
  - If the signal is good, replace the A6 Frac–N.
2. If the signal is bad, turn the signal generator power off, remove the A6 Frac–N, and measure the signal at P33–15 again.
  - If the signal is good, replace the A6 Frac–N.
3. If the signal is still bad, measure P41–5 on the A7 Reference.
  - If the signal is good, at P41–5, replace the A31 Motherboard.
  - If the signal is bad on P41–5, replace the A7 Reference.

### 703 Output Voltage

1. Using an oscilloscope, check 10 MHz Synthesis line on P33–15. The signal period should be 100 ns with an amplitude of approximately  $3V_{pp}$ .
  - If the signal is good, replace the A6 Frac–N.
2. If the signal is bad, turn the signal generator power off, remove the A6 Frac–N, and measure P33–15 again.
  - If the signal is good, replace the A6 Frac–N.
3. If the signal is still bad, measure P41–5 on the A7 Reference.
  - If the signal is good at P41–5, replace the A31 Motherboard.
  - If the signal is bad at P41–5, replace the A7 Reference.

### 704 Filter Test

1. Refer to [Table1-13](#), and check J1 on the A6 Frac-N:
  - a. Turn the signal generator on and remove the A6 Frac-N.
  - b. Set the signal generator to the first center frequency.
  - c. Use an extender board cable to connect a spectrum analyzer to J1.
  - d. Tune the spectrum analyzer to the first J1 frequency, and check for the correct power.
  - e. Repeat Step d for the remaining frequencies.
    - If *all* the signals at J1 are good, continue with [Step 3](#).

**Table 1-13**

Center Frequency (GHz)	J1 Frequency (GHz)	Power at J1 (dBm)
0.300	4.771	> -6
0.500	7.969	
0.750	5.971	
1.25	4.976	
2.0	7.969	
3.0	5.971	

2. If *any* signal measured in Step 1 is bad, check the signal out of the A6 Frac-N output port on the A29 20 GHz Doubler.
  - If the signal out the A29 20 GHz Doubler is good, replace the cable.
  - If the signal out the A29 20 GHz Doubler is bad, replace the A29 20 GHz Doubler.
3. If all of the signals at J1 are good, turn the signal generator off and reinstall the A6 Frac-N.
4. Check J4 at the A8 Output (shown on [on page 1-62](#)):
  - a. Power the signal generator on and remove the A8 Output.
  - b. Use an extender cable to connect a spectrum analyzer to J4.
  - c. Tune the spectrum analyzer to the first frequency in column one of [Table1-13](#), and check for approximately +10 dBm.
    - If an RF signal is present on J4, replace the A8 Output.
    - If an RF signal is not present on J4, replace the A6 Frac-N.

### **705 F/2 Test**

1. Using an oscilloscope, check the 10 MHz Synthesis line on P33–15. The signal period should be 100 ns with an amplitude of approximately  $3V_{pp}$ .
  - If the signal is good, replace the A6 Frac–N.
2. If the signal is bad, turn the signal generator power off, remove the A6 Frac–N, and measure P33–15 again.
  - If the signal is good, replace the A6 Frac–N.
3. If the signal is still bad, measure P41–5 on the A7 Reference.
  - If the signal is good at P41–5, replace the A31 Motherboard.
  - If the signal is bad at P41–5, replace the A7 Reference.

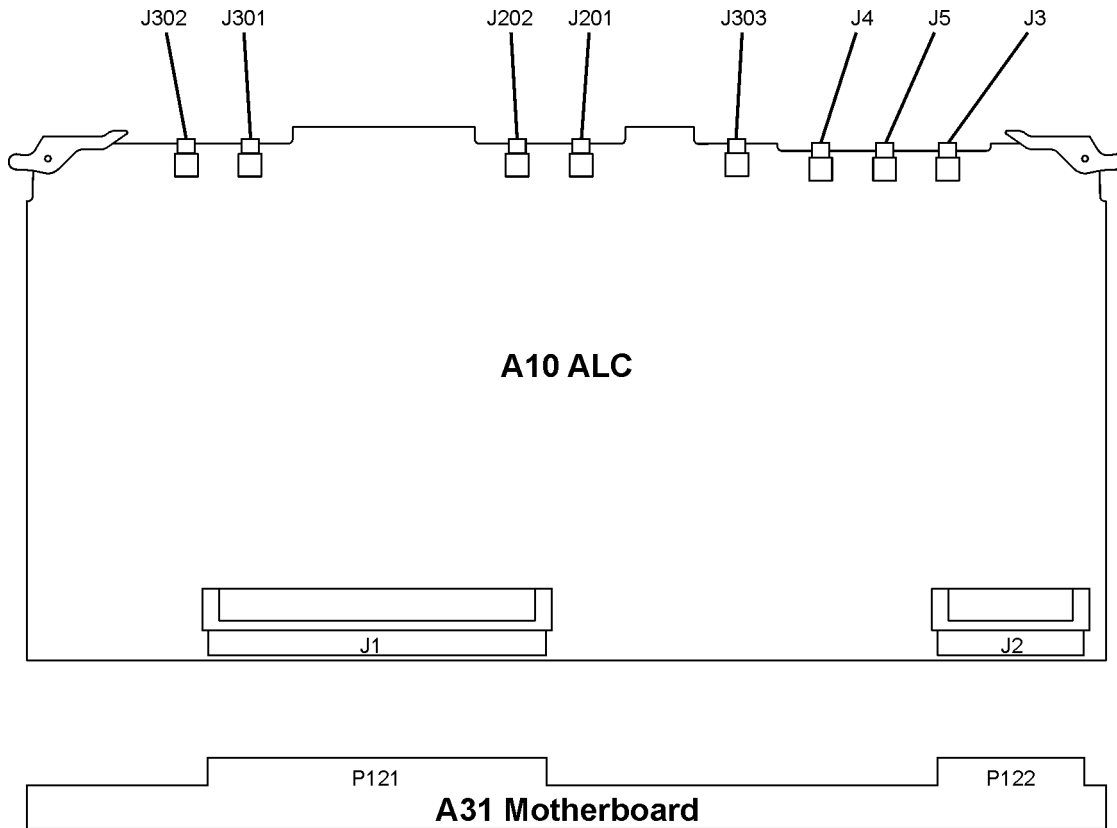
### **706 FM Path Test**

1. Using an oscilloscope, check P31–22 (FM\_On\_H):
  - a. Loop self–test 706
  - b. Check for a TTL transition from 0 Vdc to +5 Vdc.
    - If the signal is not present, refer to A5 Sampler troubleshooting.
2. If the signal is present, check P31–11 (FM):
  - a. Loop self–test 706.
  - b. Check for a 0 to 3.3 Vdc transition.
    - If the signals is present, replace the A6 Frac–N.
    - If the signal is not present, refer to A11 Pulse/Analog Modulation Generator troubleshooting.

### **707 Sweep Phase Detector Test**

1. Replace the A6 Frac–N.

### Self-Tests 9xx: A10 ALC Self-Test Errors



**Before proceeding to the reported self-test error code, check the following voltages. If any voltages are out of specification troubleshoot the supply problem first.**

Supply Voltage (Vdc)	Connector Pins	Minimum Value (Vdc)	Maximum Value (Vdc)	Origin
+32	P122-4	+31.04	+32.96	Main Supply
+15	P122-28	+14.55	+15.45	Main Supply
-15	P122-3,	-14.55	-15.45	Main Supply
+5.2	P122-2, 27	+5.04	+5.37	Main Supply
-5.2	P122-1, 26	+5.04	+5.37	Main Supply
+5.2 Digital high	P121-64, 65, 129, 130	+5.04	+5.36	Main Supply
+3.4 Digital Low	P121-60, 61, 62, 63, 125, 126, 127, 128	+3.29	+3.5	Main Supply

#### 900 Power Supply

- Replace the 10 ALC.

**901 Detector Test**

1. Using a digital voltmeter, check J3 for  $-0.6$  Vdc:
  - a. Turn the signal generator's RF power on.
  - b. Set the frequency to 10 GHz and the RF power level to +20 dBm.
  - c. Disconnect the cable from J3 of the A10 ALC (W15) and connect the cable to the voltmeter.
    - If the signal is not present, refer to highband RF loop troubleshooting.
2. If the signal is present, check J5 for  $-5.0$  Vdc:
  - a. On the signal generator, change the frequency to 1 GHz.
  - b. Disconnect the cable from J5 of the A10 ALC (W14) and connect the cable to the voltmeter.
    - If the signal is not present, refer to lowband RF loop troubleshooting.
    - If the signal is present, replace the A10 ALC.

**902 Detector Level to ALC Ref**

1. Using a digital voltmeter, check J5 for  $-5.0$  Vdc:
  - a. Turn the signal generator's RF power on.
  - b. Set the frequency to 1 GHz and the RF power level to +20 dBm.
  - c. Disconnect the cable from J5 of the A10 ALC (W14) and connect the cable to the voltmeter.
    - If the signal is not present, refer to lowband RF loop troubleshooting.
2. If the signal is present, check J3 for  $-0.6$  Vdc:
  - a. On the signal generator, change the frequency to 10 GHz.
  - b. Disconnect the cable from J3 of the A10 ALC (W15) and connect the cable to the voltmeter.
    - If the signal is not present, refer to highband RF loop troubleshooting.
    - If the signal is present, replace the A10 ALC.

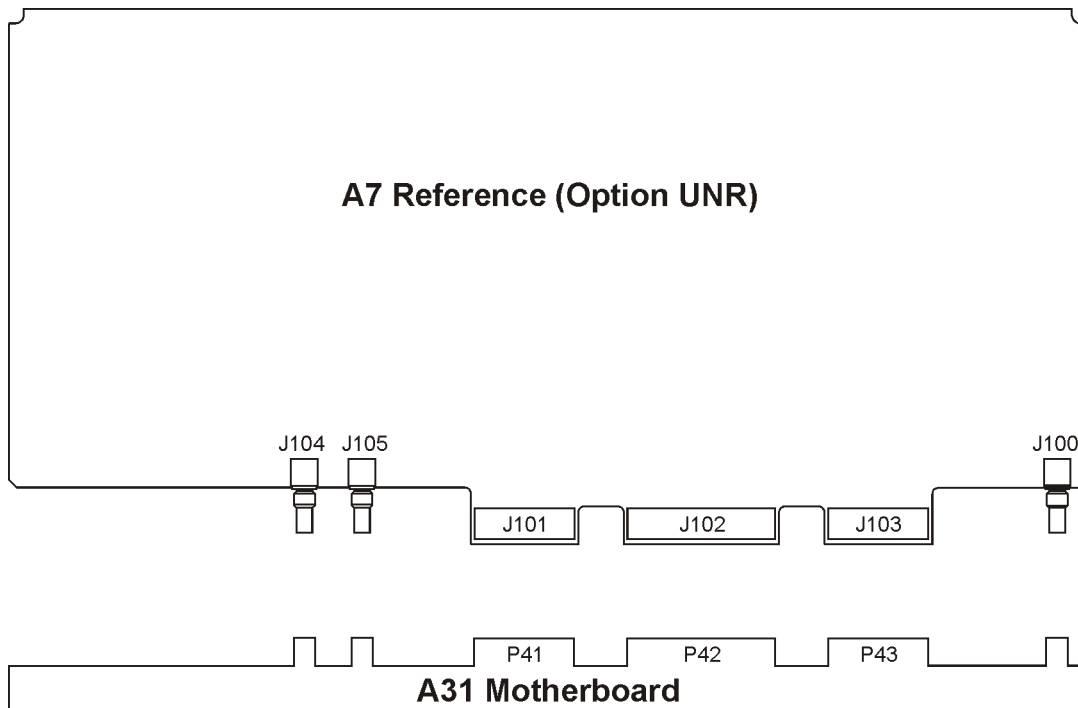
**903 Level Test**

1. Using a digital voltmeter, check J3 for  $-0.6$  Vdc:
  - a. Turn the signal generator's RF power on.
  - b. Set the frequency to 10 GHz and the RF power level to +20 dBm.
  - c. Disconnect the cable from J3 of the A10 ALC (W15) and connect the cable to the voltmeter.
    - If the signal is not present, refer to highband RF loop troubleshooting.
    - If the signal is present, replace the A10 ALC.

**904 Scalar Mod Pulse**

- Replace the A10 ALC.

## Self-Tests 10xx: A7 Reference (Option UNR) Self-Test Errors



**Before proceeding to the reported self-test error code, check the following voltages. If any voltages are out of specification troubleshoot the supply problem first.**

Supply Voltage (Vdc)	Connector Pins	Minimum Value (Vdc)	Maximum Value (Vdc)	Origin
+15	P42-6, 21	+14.55	+15.45	Main Supply
-15	P42-2, 17	-14.55	-15.45	Main Supply
+9	P42-5, 20	+8.82	+9.18	YIG Driver

### 1000 Power Supply

- Replace the A7 Reference.

**1001 10 MHz Test**

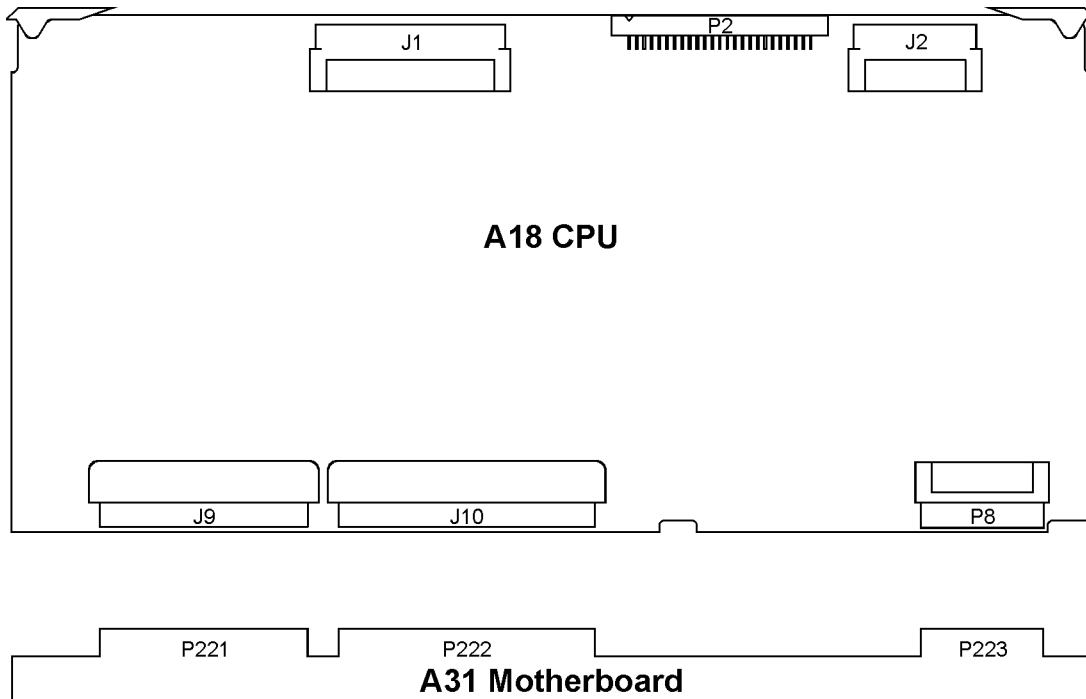
1. Using an oscilloscope, check P41–2 for a 10 MHz signal greater than 1.12 V<sub>pp</sub>. If the signal is present, replace the A7 Reference.
2. If the signal is not present, replace the internal 10 MHz standard.

**1002 1 GHz Test**

- Replace the A7 Reference.



## Self-Tests 11xx: A18 CPU Self-Test Errors



### 1100 Power Supply

The A18 CPU self-test verifies the presence of the supplies listed. These supplies are not checked during the turn-on check and are not necessary for the turn-on check to pass.

1. After running self-test, View **Details** and see which supply failed.
2. If the 10 VRef has failed, replace the A18 CPU. The 10 VRef is generated on the A18 CPU and used for the ADC circuit.
3. For a self-test failure other than the 10 VRef, measure the appropriate connector pin listed in the following table.

Connector P223	Supply Voltage	Voltage Range
Pin 1	-5.2 Vdc	-5.2 ±.1 Vdc
Pin 17	-6 Vdc	-6 ±.1 Vdc
Pin 18	+9 Vdc	+9 ±.1 Vdc

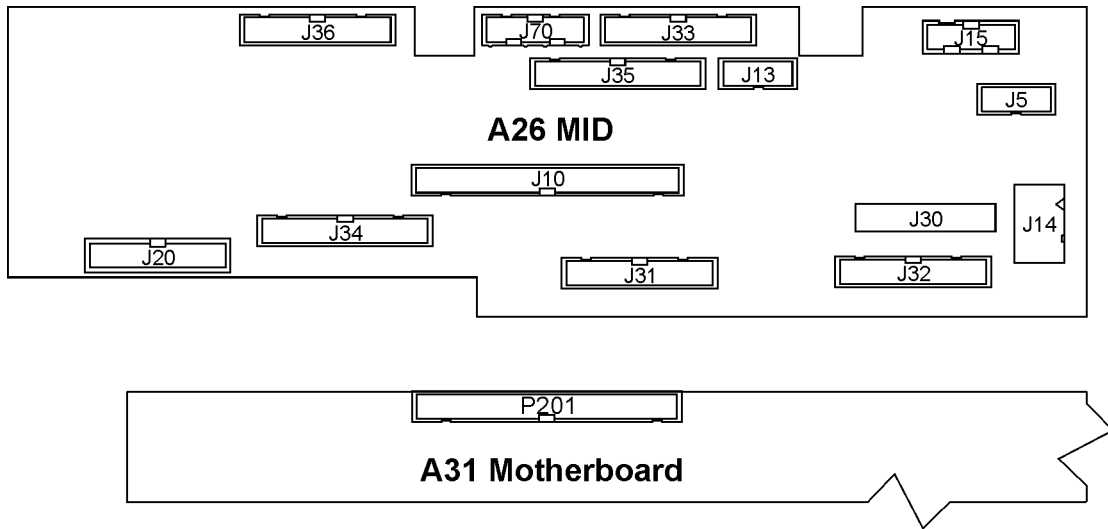
4. If the voltages are present on the A31 Motherboard, turn power off, remove the A18 CPU and inspect the connector. If the pins look good, replace the A18 CPU.

5. If a supply voltage is not present on the connector, measure the appropriate point listed in the following table:

<b>Connector P112</b>	<b>Supply Voltage</b>	<b>Voltage Range</b>
Pin 1, 2, 26, 27	-5.2 Vdc	-5.2 ± 0.1 Vdc
Pin 19, 44	-6 Vdc	-6 ± 0.1 Vdc
Pin 17, 18, 42	+9 Vdc	+9 ± 0.1 Vdc

6. If the voltage is present on P112 but not present on P223, replace the A31 Motherboard.
7. If the voltages are not present on P112, troubleshoot the A9 YIG Driver.

### Self-Tests 12xx: A26 MID Self-Test Errors



**Before proceeding to the reported self-test error code, check the following voltages in. If any of these voltages are out of specification troubleshoot the supply problem first.**

Supply Voltage (Vdc)	E8267C Connector Pins	All Other Models Connector Pins	Minimum Value (Vdc)	Maximum Value (Vdc)	Origin
+32	P201-11	P201-1	+31.04	+32.96	Main Supply
+15	P201-12, 13, 14	P201-2, 3, 4	+14.55	+15.45	Main Supply
-15	P201-21, 22	P201-11, 12	-15.45	-14.55	Main Supply
+5.2	P201-7, 8, 9, 10, 23, 24, 25, 26, 27, 28	P201-13, 14, 15, 16, 17, 18	+5.04	+5.36	Main Supply
+10	P201-15, 16, 17, 18, 19, 20	P201-5, 6, 7, 8, 9, 10	+9.7	+10.3	Main Supply
+8	P201-39	P201-29	+7.5	+8.5	MID
-7	P201-40, 43, 56	N/A	-7.21	-6.79	Main Supply
-5.2	P201-41, 42	P201-31, 32	-5.36	-5.04	YIG Driver
+5.2 Digital high	P201-33	P201-23	+5.04	+5.36	Main Supply
+3.4 Digital Low	P201-34	P201-24	+3.3	+3.5	Main Supply

### 1200 Power Supply

1. Press **View Details**, highlight Self Test 1200, then press **View Details** again.
2. From the displayed self-test results, determine which supply or supplies failed.
3. Refer to the following table; disconnect one microcircuit at a time and run self-test 1200.

Microcircuit	A26 MID Connector	+12V	+8V	+10V	+9V	-5.2V	+5.2V	+15V	-15V
A30 Modulation Filter	J31	✓	✓	✓				✓	✓
A29 20 GHz Doubler	J32	✓	✓			✓	✓	✓	✓
A27 40 GHz Doubler	J33		✓	✓		✓	✓	✓	✓
A35 I/Q Modulator	J34	✓	✓		✓		✓	✓	✓

- If the test passes after disconnecting one or more microcircuits, replace the microcircuit.
- If self-test still fails after disconnecting all the microcircuits, replace the A26 MID.

### 1201 Mod Filter

1. Disconnect the cable between the A23 Low Band Coupler/Detector and the A30 Modulation Filter, and connect a spectrum analyzer to the cable.
2. Tune the source across the low band frequencies (250 kHz to 3.2 GHz) and record the lowest power level.
3. Disconnect the cable coming from the A29 20 GHz Doubler, and connect the spectrum analyzer to this cable.
4. Tune the source across the A29 20 GHz Doubler band of frequencies (3.2 GHz to 20 GHz) and record the lowest power level.
5. Compare the levels recorded to the levels shown on the RF Path Block Diagrams on page 1-109.
  - If the power level in both paths is good, replace the A30 Modulation Filter.
  - If the power level in *either* path is bad, troubleshoot that path.
  - If the power level in both paths is bad, check the signal levels out of the A28 YIG Oscillator.

### 1202 A29 20 GHz Doubler

1. Disconnect the cable between the A28 YIG Oscillator and the A29 20 GHz Doubler, and connect a spectrum analyzer to the cable.
2. Tune the source frequency across the A28 YIG Oscillator range (3.2 GHz to 10 GHz) noting the lowest power level.
3. Compare the measured level to the level shown on the RF Path Block Diagrams on page 1-109.
  - If the power level is good, replace the A29 20 GHz Doubler.
  - If the power level is bad, replace the A28 YIG Oscillator.

### 1203 40 GHz Doubler

1. Disconnect the 0 to 20 GHz cable between the A30 Modulation Filter and the A27 40 GHz Doubler, and connect a spectrum analyzer to the cable.
2. Tune the source from 250 kHz to 20 GHz, and record the lowest power level.
3. Disconnect the 10 to 20 GHz cable that comes from the A30 Modulation Filter, and connect the spectrum analyzer to this cable.
4. Tune the source from 20 GHz to 40 GHz, recording the lowest power level.
5. Compare the levels recorded to the levels shown on the RF Path Block Diagrams on page 1-109.
  - If both power levels are good, replace the A27 40 GHz Doubler.
  - If either power level is bad, troubleshoot the path.

### 1204 RF Path

This test checks for a dc voltage on the A10 ALC from the A23 Low Band Coupler/Detector and A24 High Band Coupler and A25 High Band Detector.

1. Connect a spectrum analyzer to the RF output of the signal generator.
2. Turn the RF power on and verify the presence of an RF signal on the output.
  - If no RF signal is present, troubleshoot the RF problem using the RF Path procedure.
3. If an RF signal is present on the RF output, set the signal generator to 4 GHz and 0 dBm.
4. Measure the dc voltage on the cable going to J3 of the A10 ALC. The signal should be > -600 mV.
  - If the signal at J3 is good, go to step [Step 6](#).
5. If no dc signal is present on the cable to J3, check the output at the high band detector.
  - If the signal is good at the detector, replace the cable.
  - If no signal is present at the output of the high band detector, replace the high band detector.
6. If the signal is good at J3, set the signal generator's frequency to <1 GHz, the power to 0 dBm, and measure the dc voltage on the cable going to J5 on the A10 ALC.
  - If the dc voltage is -5.25 Vdc, replace the A10 ALC.
7. If other dc voltages are present, check for dc voltage on the output of the low band detector.
  - If a dc voltage is present, replace the cable.
  - If no dc voltage is present, replace the low band detector.

## 1205 LB Pulse Mod

### Lowband Pulse On

1. Disconnect the cable from J5 of A10 ALC, and connect the cable to a DVM (this is the lowband detector output).
2. On the signal generator, set the following:  
Center Frequency: 3 GHz  
Power: +20 dBm  
Pulse Modulation: On  
Period: 40s  
Pulse Width: 10 ns  
RF: On
3. The voltage measured by the DVM should be approximately 0V. If it is not, use an oscilloscope to view P131-6 of the A31 Motherboard (this is the pulse signal out of the A11 Pulse/Analog Modulation Generator).

Change the pulse period to 1 ms and the pulse width to 500  $\mu$ s.

- If the pulse is not present, perform the A11 Pulse/Analog Modulation Generator self-test, and follow the troubleshooting procedure.
4. If pulse modulation is working, perform the A8 Output self-test.
    - If the self-test passes, refer to [“Troubleshooting the RF Path” on page 1-76](#), and check the lowband path.
    - If the self-test fails, refer to the A8 Output test troubleshooting.

### Lowband Pulse Off

1. Disconnect the cable from J5 of A10 ALC, and connect the cable to a DVM (this is the lowband detector output).
2. On the signal generator, set the following:  
Center Frequency: 3 GHz  
Power: +20 dBm  
Pulse Modulation: On  
Period: 40s  
Pulse Width: 39.9s  
RF: On
3. The voltage measured by the DVM should be approximately -2.2 V. If it is not, use an oscilloscope to view P131-6 of the A31 Motherboard (this is the pulse signal out of the A11 Pulse/Analog Modulation Generator).

Change the pulse period to 1 ms and the pulse width to 500  $\mu$ s.

- If the pulse is not present, perform the A11 Pulse/Analog Modulation Generator self-test, and follow the troubleshooting procedure.
4. If pulse modulation is working, perform the A8 Output self-test.
    - If the self-test passes, refer to [“Troubleshooting the RF Path” on page 1-76](#), and check the lowband (<3.2 GHz) path.
    - If the self-test fails, refer to the A8 Output test troubleshooting.

### 1206 20 GHz IQ Modulator

1. If the power supplies 8V AF, 2.5V AF, 9V AFSW, 12V AFSW, 15V VLIMF, or –15VSWBIAS fail, refer to the table on page 1-52, and check the supplies used by the A35 I/Q Modulator as they leave A26 MID connector.

If the signals are good at the A26 MID connector, replace the A35 I/Q Modulator.

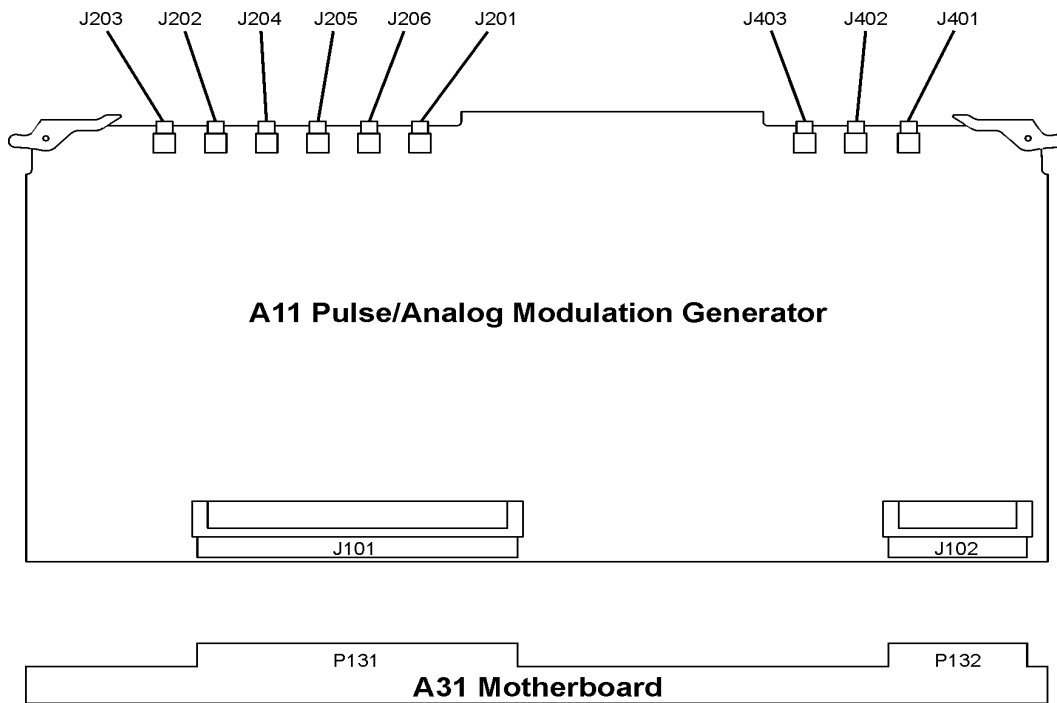
2. If the VD724 Doubler, test index 6, fails, replace the A35 I/Q Modulator.
3. If self-test TC672RF indexes 8, 9, 11, or 12 fail:
  - a. Remove the cable from J2 of the A29 20 GHz Doubler.
  - b. While measuring the signal at J2 with a spectrum analyzer, run self-test 1206. You should see a +20 dBm signal at 5 GHz.
    - If the signal is bad, troubleshoot the RF path.
    - If the signal is good, and TC672RF indexes 8, 11, or 12 have failed, replace the A35 I/Q Modulator.
    - If the signal is good, and TC672RF indexes 9 has failed, you must also check the I/Q signals from the A13 I/Q Multiplexer:
      1. Remove the cable from J6 (I) of the A35 I/Q Modulator, and connect it to a DVM.
      2. Execute a single 1206 self-test. The signal on the DVM should pulse to approximately –0.165 Vdc.

If the signal is bad, refer to the A13 I/Q Multiplexer troubleshooting.
      3. If the signal is good, reconnect the cable to J6, remove the cable to J7 (Q), and connect this cable to the DVM.
      4. Execute a single 1206 self-test. The signal on the DVM should pulse to approximately a few millivolts.

If the signal is bad, refer to the A13 I/Q Multiplexer troubleshooting.

If both the I and Q signals are good, replace the A35 I/Q Modulator.
4. If self-test TC672RF indexes 10 fails, replace the A35 I/Q Modulator.

## Self-Tests 13xx: A11 Analog/Pulse Modulation Generator Self-Test Errors



Before proceeding to the reported self-test error code, check the following voltages. If any of these voltages are out of specification troubleshoot the supply problem first.

Supply Voltage (Vdc)	Connector Pins	Minimum Value (Vdc)	Maximum Value (Vdc)	Origin
+15	P132-28	+14.55	+15.45	Main Supply
-15	P132-3	-14.55	-15.45	Main Supply
+5.2	P132-2, 27	+5.04	+5.37	Main Supply
-5.2	P132-1, 26	-5.1	-5.3	YIG Driver
+5.2 Digital high	P131-64, 65, 129, 130	+5.04	+5.36	Main Supply
+3.4 Digital Low	P131-60, 61, 62, 63, 125, 126, 127, 128	+3.29	+3.5	Main Supply

### 1300 Power Supply

- Replace the A7 Reference.



### **1301 Internal Pulse Generator Clock**

1. Using an oscilloscope, measure P131–91 for a 10 MHz signal at 3.5 V<sub>pp</sub>.
  - If the signal is good, replace the A11 Pulse/Analog Modulation Generator.
2. If the signal is bad, check P41–7.
  - If the signal is good on P41–7, replace the A31 Motherboard.
  - If the signal is bad on P41–7, replace the A7 Reference.

### **1302 Output**

- Replace A11 Pulse/Analog Modulation Generator.

### **1303 Voltage Ref DAC**

- Replace A11 Pulse/Analog Modulation Generator.

### **1304 20 GHz Pulse**

- Replace A11 Pulse/Analog Modulation Generator.

### **1305 Not Used**

### **1306 Standard 3 GHz Pulse**

- Replace A11 Pulse/Analog Modulation Generator.

### **1307 High Performance 3 GHz Pulse**

- Replace A11 Pulse/Analog Modulation Generator.

### **1308 Numeric Synthesizer**

- Replace A11 Pulse/Analog Modulation Generator.

### **1309 Function Generator Channel 1**

- Replace A11 Pulse/Analog Modulation Generator.

### **1310 Function Generator Channel 2**

- Replace A11 Pulse/Analog Modulation Generator.

### **1311 Frequency Modulator**

- Replace A11 Pulse/Analog Modulation Generator.

### **1312 Low Frequency Out**

- Replace A11 Pulse/Analog Modulation Generator.

**1313 Amplitude Modulation**

- Replace A11 Pulse/Analog Modulation Generator.

**1314 External 1**

- Replace A11 Pulse/Analog Modulation Generator.

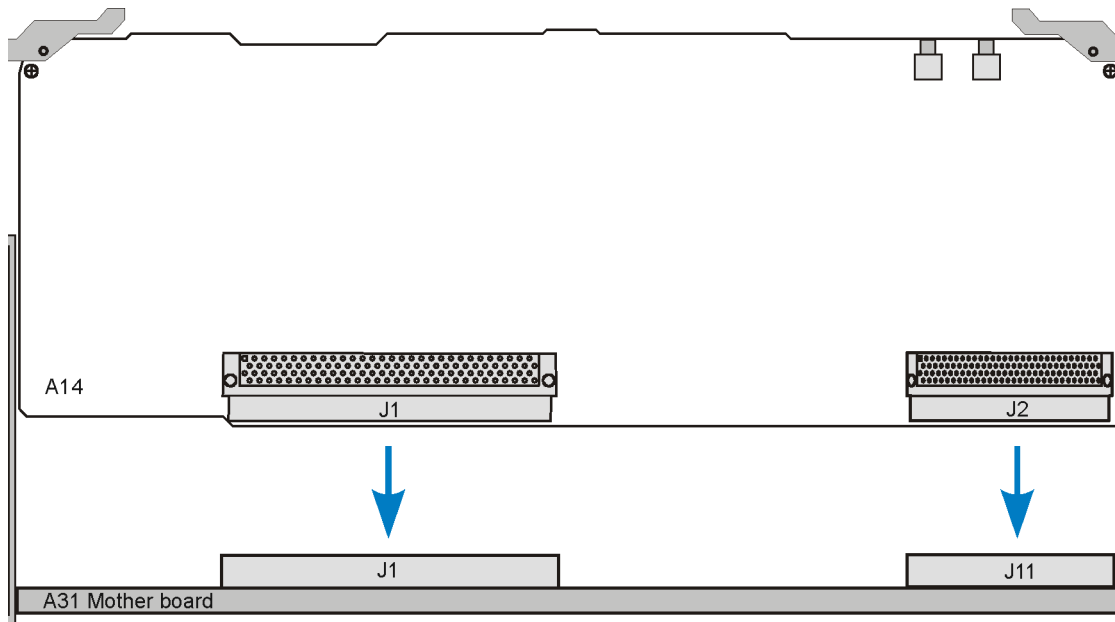
**1315 External 2**

- Replace A11 Pulse/Analog Modulation Generator.

**1316 AM Path Loss**

- Replace A11 Pulse/Analog Modulation Generator.

### Self-Tests 16xx for the A14 Baseband Generator (Option 002)



Power Supply Voltage (Vdc)	A31 Motherboard Connector Pins	Minimum (Vdc)	Maximum (Vdc)	Origin
+32	P162 - 4	+31.04	+32.96	Main Supply
+15	P162 - 28	+14.55	+15.45	Main Supply
-15	P162 - 3	-15.45	-14.55	Main Supply
-5.2 V2	P162 - 1, 26	-5.36	-5.04	A31 Motherboard
+5.2	P162 - 5, 27	+5.04	+5.36	Main Supply
+5.2 D	P161 - 64, 65, 129, 130	+5.04	+5.36	Main Supply
+3.4 VD	P161 - 60, 61, 62, 63, 125, 126, 127, 128	+3.30	+3.50	Main Supply
+2.6 VD	P161 - 57, 58, 59, 123, 124	+2.52	+2.68	Main Supply
+1.95 VD	P161 - 52, 118	+1.89	+2.01	A31 Motherboard
+1.8 VD	P161 - 55, 56, 120, 121, 122	+1.75	+1.85	A31 Motherboard

### 1600 Host <-> BBG Comm

- If the +3.4 VD, +2.6 VD, and +1.9 VD supply voltages are good on the A31 Motherboard, replace the A14 Baseband Generator.
- If the +3.4 VD or +2.6 VD supply voltages are bad on the A31 Motherboard, check the origin of the supply.
  - If the supply voltage is good at the origin, replace the A31 Motherboard.
  - If the supply voltage is bad at the origin, troubleshoot the A19 Power Supply.
- If the +1.9 VD supply voltage is bad on the A31 Motherboard, check the +3.4 VD supply at the A19 Power Supply.
  - If the +3.4 VD supply is good at the A19 Power Supply, replace the A31 Motherboard.
  - If the +3.4 VD supply is bad at the A19 Power Supply, troubleshoot A19 Power supply.

### 1601 Apps 1 <-> Apps 2 Comm

- If the +1.8 VD supply voltage is good on the A31 Motherboard, replace the A14 Baseband Generator
- If the +1.8 VD supply voltage is bad on the A31 Motherboard, check the +2.6 VD supply at the A19 Power Supply.
  - If the +2.6 VD supply is good at the A19 Power Supply, then replace the A31 Motherboard.
  - If the +2.6 VD supply is bad at the A19 Power Supply, then troubleshoot the A19 Power supply.

### 1602 Apps 1 <-> SH4 Comm

- Replace the A14 Baseband Generator

### 1603 Apps 2 <-> SH4 Comm

- Replace the A14 Baseband Generator

### 1604 FLiegen <-> Apps 2 Comm

- Replace the A14 Baseband Generator

### 1605 SRAM Test

- Replace the A14 Baseband Generator

### 1606 SDRAM Test

- Replace the A14 Baseband Generator

### 1607 Paren <-> SH4 Comm

- Replace the A14 Baseband Generator

### 1608 VCO Tune Test

- If the +32 V,  $\pm 15$ V,  $-5.2$  V2, and + 5.2V supply voltages are good on the motherboard, use an oscilloscope to check the 10 MHz signal on the A31 Motherboard at P161 pins 26 and 91. The signal should have a period of 100 ns with an amplitude greater than 0.4 Vpp.
  - If the 10 MHz signal is good, replace the A14 Baseband Generator.
  - If the 10 MHz signal is bad, check it at the A7 Reference.
    - If the 10 MHz signal is bad at the A7 Reference, refer to A7 Reference troubleshooting.
    - If the 10 MHz signal is good at the A7 Reference, replace the A31 Motherboard.
- If the +32 V,  $\pm 15$  V, and +5.2 V supply voltages are bad on the motherboard, check the origin of the supply.
  - If the supply voltage is good at the origin, replace the A31 Motherboard.
  - If the supply voltage is bad at the origin, troubleshoot the A19 Power Supply.
- If the  $-5.2$  V2 supply voltage is bad on the motherboard, check the -7 V supply voltage at the A19 Power Supply.
  - If the -7 V supply voltage is good at the A19 Power Supply, replace the A31 Motherboard.
  - If the -7 V supply voltage is bad at the A19 Power Supply, troubleshoot the A19 Power supply.

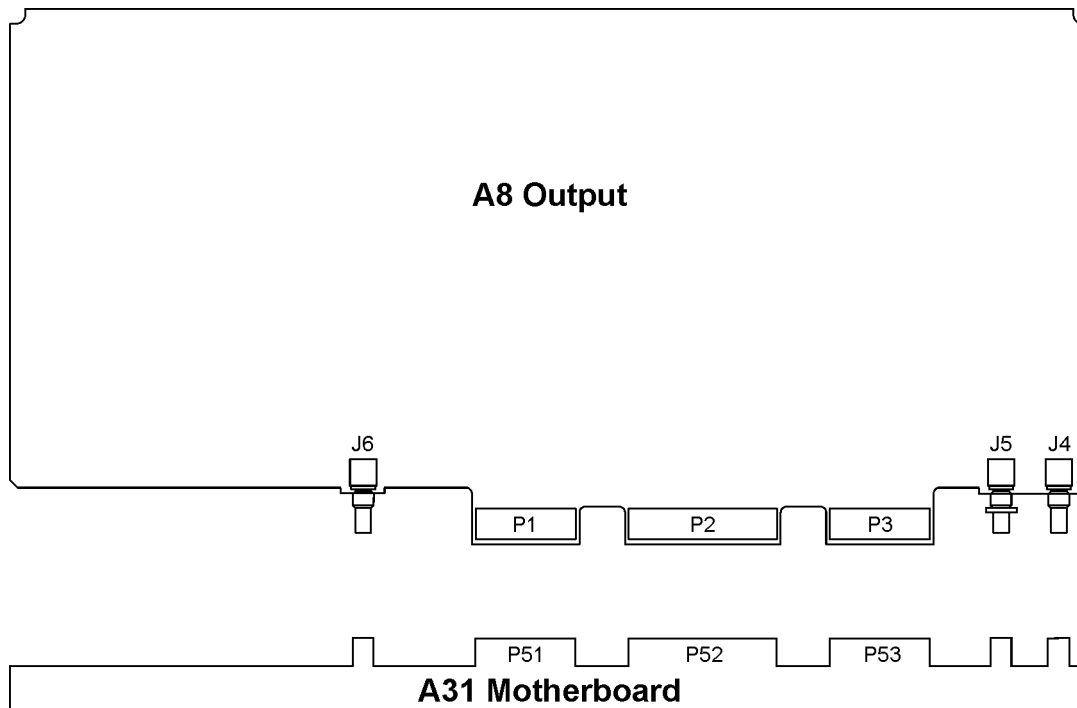
### 1609 IQ DAC Output

- Replace the A14 Baseband Generator

### 1610 PLL Test

- Replace the A14 Baseband Generator

## Self-Tests 22xx: A8 Output Self-Test Errors



**Before proceeding to the reported self-test error code, check the following voltages. If any voltages are out of specification troubleshoot the supply problem first.**

Supply Voltage (Vdc)	Connector Pins	Minimum Value (Vdc)	Maximum Value (Vdc)	Origin
+15	P52-6, 21	+14.55	+15.45	Main Supply
-15	P52-2, 17	-14.55	-15.45	Main Supply
+5.2	P52-14, 29	+5.04	+5.36	Main Supply
+9	P52-5, 20	+8.82	+9.18	YIG Driver
-6	P52-3, 18	-5.88	-6.12	YIG Driver

### 2200 Ground and PTAT Test

- Replace A8 Output.

### 2201 Prelevel Loop Test

1. With the signal generator powered on, carefully remove the A8 Output.
2. Set the signal generator to 3 GHz CW.

3. Connect a spectrum analyzer to the A6 Frac-N RF output at J4 of the A8 Output. The signal at J4 should be at 3 GHz and  $\geq 0$  dBm.
  - If the signal is not present or at the correct level, replace the Frac-N.
  - If the signal is present, replace the A8 Output.

---

**WARNING** Do not re-install the A8 Output with the signal generator powered on. This can cause serious damage to the signal generator.

---

#### **2202 Switching Filter Test**

- Replace the A8 Output.

#### **2203 ALC Mod System Test**

- Replace the A8 Output.

#### **2204 Pulse Mod System Test**

- Replace the A8 Output.

#### **2205 RF Path Test**

- Replace the A8 Output.

## Troubleshooting Unlocks

The phase lock loop refers to part of the frequency generating circuit used to maintain the phase relationship between the frequency generation loop and a reference frequency. By maintaining the phase relationship the frequency accuracy of the signal generator is guaranteed.

To maintain frequency accuracy the phase lock loop compares the phase of a signal from the reference assembly to the phase of the frequency loop signal. If the signals are slightly out of phase, the phase comparator circuit adjusts the frequency loop signal until the two signals are in phase. If the phase comparator circuit cannot adjust the phase of the frequency loop signal to agree with the reference signal, the phase comparator rails and generates an unlocked message. The unlock message is immediately displayed on the front panel display.

There are four phase lock circuits in the frequency generation loop that can generate error messages. These phase lock loops are located on the A6 Frac-N, A5 Sampler, and A7 Reference. There is also one other phase lock loop on the A11 Pulse/Analog Modulation Generator that can generate an error message when the signal generator is in phase modulation mode.

### 508 A6 Frac-N Loop Unlock

A 508 Frac-N unlock message indicates a failure of the A6 Frac-N.

1. Check P33-15 on the A31 Motherboard for the 10 MHz sync. approximately 2 V<sub>pp</sub>.
2. If the signal is present replace the A6 Frac-N.
3. If the signal is not present, troubleshoot back to the A7 Reference.

### 513 1 GHz Out of Lock

A 513 1 GHz Out of Lock message indicates a failure on the A7 Reference.

- Replace the A7 Reference.

### 514 Reference Oven Cold

The Reference Oven Cold Error message indicated the reference has not been connected to electrical power for 30 minutes. This message appears when the signal generator is unplugged or the reference assembly is removed. The message is controlled by a timer and should turn off after 30 minutes. This is not a failure unless the message does not go off after 30 minutes. If it continues to be displayed after 30 minutes, replace the A7 Reference.



## 515 10 MHz Signal Bad

A 515 10 MHz Signal Bad message indicates a problem on the A7 Reference.

A7 Reference (Standard)

- Replace the A7 Reference.

A7 Reference (Option UNR)

1. Check the 10 MHz signal into the A7 Reference from the 10 MHz standard.
2. The signal should be 10 MHz 1.8 V<sub>pp</sub> into 1 MΩ.
3. If the 10 MHz signal is bad, replace the A32 10 MHz Crystal Oscillator.
4. If the signal is good, replace the A7 Reference.

## 520 Sampler Unlocked

A 520 Sampler unlock message indicates a failure of the A5 Sampler VCO loop.

1. Run self-test. If self-test fails, troubleshoot the problem reported.
2. Power-up the signal generator. Remove the A5 Sampler. Probe the mmx connection center pin on the right side of the A31 Motherboard in the A5 Sampler slot. There should be a 1 GHz signal >0 dBm.
3. If the 1 GHz signal is present, replace the A5 Sampler.
4. If the 1 GHz signal is not present, replace the A7 Reference.

---

**NOTE** Turn the signal generator off before re-installing any assembly.

---

## 521 YO Loop Unlocked

A 521 YO Loop unlocked message indicates a failure of the A5 Sampler's YO Phase detector circuit.

1. Set the signal generator to 5 GHz.
2. With the signal generator on, remove the A5 Sampler. Probe the mmx connectors on the A31 Motherboard

**Table 1-14**

Connector	Signal
right mmx connector	1 GHz >0 dBm from A7 Reference
center mmx connector	5 GHz from A29 20 GHz Doubler -6 dBm
left mmx connector	approximately 850 MHz >-6 dBm from A5 Sampler

3. If all signals are present replace the A5 Sampler.
4. If any signal is not present, troubleshoot to the signal generator and replace that assembly.

---

**NOTE** Turn the signal generator off before re-installing any assembly.

---

## 625 Internal Pulse Generator Unlock

A 625 internal pulse generator unlocked message indicates a failure on the A11 Pulse/Analog Modulation Generator.

- Replace the A11 Pulse/Analog Modulation Generator.

## 626 Internal Mod Source Unlock

A 626 Internal Mod Source Unlock error message indicates a problem with the digital 10 MHz signal to the A11 Pulse/Analog Modulation Generator. This error message is turned on if the signal generator is in phase modulation mode and there is a problem with the 10 MHz digital signal to the in phase clock.

1. Set the signal generator to phase modulation mode.
2. Measure pin P131-91. The waveform is not a sine wave, but more like a distorted pulse waveform  $>2 V_{pp}$ .
3. If the waveform is present, replace the A11 Pulse/Analog Modulation Generator.
4. If the signal is not present, replace the A7 Reference.

---

## Troubleshooting Unlevels

A leveled output power is obtained comparing a detected voltage with a reference voltage. The reference voltage is generated using DACs on the A10 ALC and the detected voltage is generated by coupling off a portion of the RF output signal and converting it to dc using detector diodes. When the reference and detected levels are the same the integrated output level remains constant. When the detected and reference levels are not the same, the integrator output ramps either up or down to increase or decrease the detected level. If the integrator can not get the detected voltage and the reference voltage to match, an unlevelled annunciator is displayed.

The Automatic Leveling Circuit (ALC) uses two detectors and two modulator diodes. The A23 Low Band Coupler/Detector is used for frequencies 2 GHz and below. The A25 Highband Coupler/Detector is used for all frequencies above 2 GHz. The modulator in the A23 Low Band Coupler/Detector is used to control the RF amplitude for frequencies 3.2 GHz and below. The modulator in the A30 Modulation Filter is used to control the amplitude for frequencies above 3.2 GHz.

The RF path must provide a minimum power level to the ALC loop for the ALC loop to work properly. The minimum power required is slightly higher than the maximum leveled power. The first step to troubleshooting a leveling problem is to verify the RF path power level.

### **Troubleshoot and correct any unlock problems before troubleshooting unlevelled problems.**

If the unlevelled annunciator is on:

1. Verify the signal generator's amplitude is not set higher than the maximum level specified on the data sheet. Verify that the signal generator's RF output is terminated into 50 ohms. If the unlevelled indication turns off after resetting the amplitude or terminating the RF output into 50 ohms, the signal generator is operating correctly. If the unlevelled indicator remains on, proceed to step 2.
2. Using a spectrum analyzer check the RF signal level at the RF output connector.
  - a. Signal generator and spectrum analyzer setup:

Signal Generator:

- Turn ALC Off
- Set Amplitude to 30 dBm
- Turn Modulation Off
- Turn RF On
- Set Sweep to Frequency
- Set Sweep Type to Step
- Set Start Frequency to 250 kHz
- Set Stop Frequency to 3.2 GHz
- Set Number of Points to 500

Spectrum Analyzer:

- Set Start Frequency to 225 kHz
- Set Stop Frequency to 3.25 GHz
- Set Reference Level to +30 dBm
- Set Display to Max Hold

- b. Connect the RF output of the signal generator to the spectrum analyzer. Measure and record the minimum power level.
- c. Set the signal generator and spectrum analyzer start/stop frequencies to the next start/stop frequencies in [Table 1-15](#). Repeat step b above.

**Table 1-15**

Signal Generator		Spectrum Analyzer	
Start	Stop	Start	Stop
3.2 GHz	20 GHz	3.15 GHz	20 GHz
20 GHz	19.5 GHz	40 GHz	40 GHz

- d. If any of the frequency ranges do not produce power levels  $\geq$  the maximum leveled power shown in the [Table 1-16](#), set the signal generator to the frequency with the lowest power level and measure the power with a power meter. If the power level is low, troubleshoot the RF path before proceeding.

**Table 1-16**

20 GHz Models	Standard	Option 1EA	Option 1E1	Option 1E1 with 1EA
250 kHz to 3.2 GHz	+13 dBm	+16 dBm	+11 dBm	+15 dBm
3.2 GHz to 20 GHz	+13 dBm	+20 dBm	+11 dBm	+18 dBm
40 GHz Models				
250 kHz to 3.2 GHz	+9 dBm	+15 dBm	+7 dBm	+14 dBm
3.2 GHz to 20 GHz	+9 dBm	+18 dBm	+7 dBm	+16 dBm
20 GHz to 40 GHz	+9 dBm	+14 dBm	+7 dBm	+12 dBm

- 3. If the RF signal levels are good, most likely the problem is either a detector, ALC, or modulator. Before proceeding, turn ALC On and set the signal generator to maximum leveled power for the model and options you have and note the frequencies where the unlevelled condition occur. Later, when troubleshooting in ALC Off mode the unlevelled indication is turned off.

4. For each of the failed conditions listed, always start with the signal generator set to the following settings.
  - ALC Mode ALC Off
  - Amplitude +30 dBm
  - Attenuator Hold Mod On
  - RF On
  - Modulation Off

**Conditions:**

5. Unleveled only between 250 kHz and 2 GHz.  
If the unleveled problem only occurs between 250 kHz and 2 GHz, the problem is most likely the A23 Low Band Coupler/Detector.
  - a. Checking the A23 Low Band Coupler/Detector:
    - Set the signal generator to 1.9 GHz or a frequency where the signal generator is unleveled.
    - Connect a power meter or spectrum analyzer to the A23 Low Band Coupler/Detector output.
    - Set the signal generator to 1 GHz. Using the RPG adjust the amplitude level so the detected voltage on cable J5 of A10 ALC (W14) is  $-0.117$  Vdc. Using a power meter, measure the signal level at the end of the cable going to J3 of A30 Modulation Filter (W27). The power level should read  $2.3$  dBm  $\pm 0.5$  dB. If the voltage can not be adjusted to this level, troubleshoot the RF path.
    - If the problem is at some frequency other than 1 GHz, repeat the above step using the problem frequency. The dB p-p variation from 250 kHz to 2 GHz should be  $<2$  dB.
    - If the dc level is bad, replace the A23 Low Band Coupler/Detector.
    - If the signal is good, replace the A10 ALC.
6. Unleveled only between 250 kHz and 3.2 GHz. If the unleveled problem only occurs between 250 kHz and 3.2 GHz, the problem is most likely the A8 Output or A10 ALC.
  - a. Checking Lowband Modulator Drive signal.
    - Set the signal generator to a frequency between 250 kHz and 3.2 GHz. Set the amplitude so the power meter reads +21 dBm on cable W27 going to J3 on A30 Modulation Filter.
    - Measure the voltage on the center pin on A31 Motherboard connector J1122. The voltage should be around +2.0 Vdc.
    - Reduce the amplitude setting to 0 dBm and the voltage on J1122 should move towards +.15 Vdc.
    - If the voltages are not correct or do not change as power is changed, replace the A10 ALC.
    - If the voltage changes, replace the A8 Output.
7. Unleveled only between 2 GHz and 20 GHz or 40 GHz. If the unleveled condition occurs only for frequencies  $>2$  GHz to 20 GHz or 40 GHz, the problem is most likely the A25 Highband Coupler/Detector.
  - a. Checking the A25 Highband Coupler/Detector
    - Set the signal generator frequency to 19 GHz or a frequency where the signal generator is

unleveled.

- Connect a power meter or spectrum analyzer to the RF output connector.
  - Using the RPG adjust the power until the measured power level is +9 dBm. If the power can not be adjusted to this level, troubleshoot the RF path.
  - Remove the cable from J3 on the A10 ALC and measure the dc voltage on the center pin of the cable. The dc voltage should be  $-0.150 \text{ mVdc} \pm 0.05 \text{ Vdc}$ .
  - Set the power level to 0 dBm and repeat the center pin measurement. The voltage should be  $-30 \text{ mVdc} \pm 10 \text{ mVdc}$ .
  - If the voltages are good, go to step 8.
  - If the voltages are the same, replace the A25 Highband Coupler/Detector.
8. Unleveled only between 3.2 GHz and 20 GHz or 40 GHz.  
If the unleveled condition occurs between 3.2 GHz and 20 GHz or 40 GHz, the problem is most likely the A30 Modulation Filter.
- a. Checking the A30 Modulation Filter.
- Set the signal generator to 20 GHz or a frequency where the signal generator is unleveled and measured RF output level is +7 dBm. If the power can not be set to +7 dBm, troubleshoot the RF path.
  - Remove the cable going to J4 on the A30 Modulation Filter and measure the voltage on the center pin. The voltage should be approximately +4.7 Vdc.
  - Set the amplitude to  $-15 \text{ dBm}$ . The voltage on the center pin should decrease a few mVdc.
  - If the voltages are good, replace the A30 Modulation Filter.
  - If the voltages are bad, go to step 7.
9. Unleveled only between 20 GHz and 40 GHz.  
If the unleveled condition occurs between 20 GHz and 40 GHz, the problem is either with the A27 40 GHz Doubler or the A25 Highband Coupler/Detector.
- a. Checking the A25 Highband Coupler/Detector
- Using a spectrum analyzer, check at the RF output signal level to the level shown in the Maximum Leveled Power table. The RF output level must be greater than the maximum specified power level.
  - If the maximum power level is not greater than the maximum power level specified, troubleshoot the RF path starting with the signals out of the A30 Modulation Filter to the A27 40 GHz Doubler.
  - If the signal is greater than the maximum specified power level, replace the A25 Highband Coupler/Detector.
10. Unleveled at all frequencies.  
If the signal generator is unleveled at all frequencies, the problem is most likely the A10 ALC.
- a. Checking the A10 ALC.
- Run a complete self-test and troubleshoot the reported failure.

## Troubleshooting Adjustment Problems

When an adjustment does not work or fails to resolve a problem and all self-tests have passed, use the following table to locate the most likely failure.

**Table 1-17 Troubleshooting Help for Failed Adjustments**

<b>Adjustment that is failing...</b>	<b>Assemblies most likely causing failure...</b>
ADC Calibration	A18 CPU
YIG-Driver Pre-Tune Calibration	A9 YIG Driver A28 YIG Oscillator A5 Sampler A6 Frac-N
VCO Bias Frac-N Calibration	A6 Frac-N
Internal Source Calibration	A11 Pulse/Analog Modulation Generator
AM Audio Path Offset Calibration	A11 Pulse/Analog Modulation Generator
KV vs. Frequency Calibration	A6 Frac-N
Timebase Calibration	A7 Reference
FM Scale Offset Calibration	A11 Pulse/Analog Modulation Generator
FM Path Offset Calibration	A11 Pulse/Analog Modulation Generator A6 Frac-N
FM In-band Offset Calibration	A6 Frac-N
FM Inverting Amplifier Offset Calibration	A6 Frac-N
FM 1/2 Path Ratio Gain Calibration	A11 Pulse/Analog Modulation Generator
Mod Source Relative Gain Calibration	A11 Pulse/Analog Modulation Generator
FM/PM Out-of- Band Calibration	A6 Frac-N
FM/PM YO Frequency Compensation Calibration	A9 YIG Driver A28 YIG Oscillator
DC FM Calibration	A6 Frac-N A11 Pulse/Analog Modulation Generator
Low Frequency Output Calibration	A11 Pulse/Analog Modulation Generator
External Input Peak Detector Calibration	A11 Pulse/Analog Modulation Generator
ALC Dynamic Calibration	A10 ALC A30 Modulation Filter A8 Output
Power Flatness Calibration	A10 ALC RF Path
Attenuator Calibration-Low Band and High Band Power	AT1 RF Path
Attenuator Calibration-High Band and High Power	AT1 RF Path
Attenuator Calibration-Low Band and Low Power	AT1 RF Path

**Table 1-17 Troubleshooting Help for Failed Adjustments (Continued)**

<b>Adjustment that is failing..</b>	<b>Assemblies most likely causing failure..</b>
Attenuator Calibration-High Band and Low Power	AT1 RF Path
ALC Modulator Calibration	A30 Modulation Filter A8 Output
AM Gain Calibration	A11 Pulse Modulation Generator
Gain Adjustment Bypass Calibration (Frequencies $\leq$ 3.2 GHz)	A8 Output A6 Frac-N
Pulse Width Calibration	A11 Pulse/Analog Modulation Generator A30 Modulation Filter A8 Output



## Troubleshooting ADC Adjustment Failures

The ADC adjustment adjusts the ADC reference voltage to match the A18 CPU +10 Vdc reference. There are three reasons the adjustment could fail:

- problems with the +10 Vdc reference
- A18 CPU problems
- analog mux on another assembly is starting to fail

### Procedure:

1. Run self-test 1100. If self-test 1100 passes, the +10 Vdc reference is good; proceed to step 2.
2. To see if an analog mux is failing and loading the supply, turn power off and remove the A5 Sampler, A6 Frac-N, and A7 Reference.
3. Run the adjustment. If the adjustment passes, turn power off, reinstall one assembly at a time and run the adjustment until the problem assembly is located.
4. If self-test fails, turn power off, reinstall the assemblies and remove the A8 Output, A9 YIG Driver, and A10 ALC.
5. Run the adjustment. If the adjustment passes, turn power off, reinstall one assembly at a time and run the adjustment until the problem assembly is located.
6. If self-test fails, turn power off, reinstall the assemblies and remove the ribbon cable from J10 on the A26 MID (W35).
7. If self-test passes, replace the A26 MID.
8. If self-test fails, replace A18 CPU.

## Troubleshooting Performance Test Problems

If a performance test fails and all self-tests pass, use the following to find the most likely failure:

Performance test that is failing...	Action to perform...
Maximum Leveled Output Power	Refer to <a href="#">“Troubleshooting the RF Path” on page 1-76.</a>
Power Level Accuracy	Perform Power Flatness Calibration, Attenuator Calibration-Low Band and High Band Power, Attenuator Calibration-High Band and High Power, Attenuator Calibration-Low Band and Low Power, and Attenuator Calibration-High Band and Low Power.
Internal Pulse Modulation Level Accuracy Internal Pulse Modulation Rise/Fall Time Internal Pulse Modulation Minimum Pulse Width	If the frequency $\leq 3.2$ GHz, check the A11 Pulse/Analog Modulation Generator or the A8 Output.  If the frequency is $>3.2$ GHz, check A11 Pulse/Analog Modulation Generator and the A10 ALC.  If the Internal Pulse Modulation Minimum Pulse Width test fails, perform a Pulse Width Calibration prior to replacing any assembly.
DC FM Carrier Offset	Perform DC FM Calibration.  If still failing, check A11 Pulse/Analog Modulation Generator and A6 Frac-N.
External AM Frequency Response	If the frequency is $\leq 3.2$ GHz, check the A11 Pulse/Analog Modulation Generator or the A8 Output.  If the frequency is $>3.2$ GHz, check the A11 Pulse/Analog Modulation Generator and the A10 ALC.
Internal FM Frequency Response	Perform FM adjustments.  If still failing check A11 Pulse/Analog Modulation Generator and A6 Frac-N.
External Phase Modulation Frequency Response	Perform FM adjustments.  If still failing check A11 Pulse/Analog Modulation Generator and A6 Frac-N.
Internal FM Distortion	Perform FM adjustments.  If still failing check A11 Pulse/Analog Modulation Generator and A6 Frac-N.
Internal Phase Modulation Distortion	Perform FM adjustments.  If still failing check A11 Pulse/Analog Modulation Generator and A6 Frac-N.
External FM Deviation Accuracy	Perform FM adjustments.  If still failing check A11 Pulse/Analog Modulation Generator and A6 Frac-N.
External Phase Modulation Deviation Accuracy	Perform FM adjustments.  If still failing check A11 Pulse/Analog Modulation Generator and A6 Frac-N.
External Pulse Modulation ON/OFF Ratio	If the frequency is $\leq 3.2$ GHz, check the A11 Pulse/Analog Modulation Generator or the A8 Output.  If the frequency is $>3.2$ GHz, check the A11 Pulse/Analog Modulation Generator and the A10 ALC.
Harmonic Spurious	Refer to <a href="#">“Troubleshooting Harmonic Spurious” on page 1-80.</a>
Sub-Harmonic Spurious	Refer to <a href="#">“Troubleshooting Harmonic Spurious” on page 1-80.</a>
Non-Harmonic Spurious	Refer to <a href="#">“Troubleshooting Non-Harmonic Spurious” on page 1-83.</a>
Single-Sideband Phase Noise	Refer to <a href="#">“Troubleshooting the RF Path” on page 1-76.</a>
Internal EVM Digital Modulation Quality	Perform I/Q and digital calibrations.

<b>Performance test that is failing...</b>	<b>Action to perform...</b>
Digital Modulation Power Relative to CW	Perform I/Q and digital calibrations.

## Troubleshooting the RF Path

Troubleshooting RF Path procedure:

- preset the signal generator
- set a frequency
- open ALC loop (ALC Off)
- set signal generator to maximum power
- check power levels in the RF path (power levels are included on the RF block diagram)

### ALC and RF problems

1. Run a full self-test and troubleshoot any reported failures before proceeding.
2. From [Table 1-18](#) determine the frequencies where the problem occurs.

**Table 1-18**

<b>Frequencies</b>	<b>Assemblies</b>
All frequencies	A27 40 GHz Doubler (40 GHz models only) A28 YIG Oscillator A29 20 GHz Doubler A30 Modulation Filter AT1 (Option 1E1) RF Output Connector
250 kHz to 2 GHz	A6 Frac-N A8 Output A27 40 GHz Doubler A29 20 GHz Doubler A30 Modulation Filter A25 Highband Coupler/Detector AT1 (Option 1E1) RF Output Connector
250 kHz to 20 GHz	A23 Low Band Coupler/Detector A8 Output
3.2 GHz to 20 GHz/40 GHz	A27 40 GHz Doubler (40 GHz models only) A29 20 GHz Doubler A30 Modulation Filter AT1 (Option 1E1) RF Output Connector
20 GHz to 40 GHz	A25 Highband Coupler/Detector A27 40 GHz Doubler A30 Modulation Filter AT1 (Option 1E1) RF Output Connector

3. Perform the following steps:

- press Preset
- press Frequency, and set signal generator to frequency in problem area
- press Amplitude, and set to +25 dBm
- press RF ON/OFF (turn RF On)
- turn ALC Off

- Power Search Manual
  - Do Power Search
4. Using the RF Path Block Diagram, check the power levels at the points shown.
  5. Once the problem is located, verify any cable between assemblies is good before replacing the assembly.
  6. To measure the A6 Frac–N output level, with the signal generator on, remove the A8 Output and probe the right hand mmx connector’s center pin. The power level should be  $\geq +5$  dBm.

**WARNING** Always turn the signal generator off before installing any assembly.

7. If power levels look good through the path in ALC Off mode, the problem is most likely in the ALC loop. Go to troubleshooting the ALC loop.

### Troubleshooting Pulse Modulation

1. Run a full self–test and troubleshoot any reported failures before proceeding.
2. Determine the frequency of the pulse modulation problem.
3. Configure the signal generator to the pulse modulation setting that produces the problem.
4. Connect an oscilloscope to the LF OUTPUT connector. The waveform should be present on the oscilloscope.
5. If the waveform is present, continue to step 7.
6. If the waveform is not present or the signal is not the correct amplitude or type, replace the A11 Pulse/Analog Modulation Generator.
7. Turn ALC Off. If in ALC On mode, the ALC bandwidth causes a reduction in pulse amplitude at pulse widths  $< 1\mu\text{s}$ . If turning ALC Off corrects the problem, then verify the user has set up pulse modulating in either ALC Off or Power Search Modes.

### Troubleshooting Problems $< 3.2$ GHz

8. If the pulse modulation problem occurs at  $< 3.2$  GHz, check P52–23 on the A31 Motherboard. Compare the results with [Table 1-19](#).

**Table 1-19**

Pulse On	Pulse Off
+5 Vdc	0 to +5 Vdc (pulses at modulation rate)

9. If signal levels are good, replace the A8 Output.
10. If the signals are bad, replace the A11 Pulse/Analog Modulation Generator.

### Troubleshooting Problems $> 3.2$ GHz

11. If the pulse modulation problem occurs  $> 3.2$  GHz, remove the cable A30 Modulation Filter J7

(W17). Probe the end of the cable. Compare the results with [Table1-20](#).

**Table 1-20**

<b>Pulse On</b>	<b>Pulse Off</b>
+5 Vdc	0 to +5 Vdc (pulses at modulation rate)

12. If the signal levels are good, replace the A30 Modulation Filter.

13. if the signal levels are bad, replace the A11 Pulse/Analog Modulation Generator.

## Troubleshooting AT1 Attenuator

Starting from +25 dBm, the attenuator steps when the power is changed from between +5.1 dBm and +5.0 dBm. Continuing to lower the power level, the next switch occurs between -4.99 dBm and -5.0 dBm. The next change is between -14.99 dBm and -15.0 dBm and so on. The last change occurs between -104.99 dBm and -105.0 dBm.

1. If the attenuator switches at the switch points but the power does not change or the power changes more or less than expected, replace the attenuator.
2. If the attenuator does not switch, press: Utility > more 1 of 2 > Instrument Info > Options Info  
An Option 1E1 should be listed.
3. If Option 1E1 is not listed, the option is either not installed or the configuration file is bad. The signal generator will need to be returned to Agilent for service.
4. If Option 1E1 is listed, turn the signal generator off and remove W36 from J13 on the A26 MID.
5. Turn the signal generator on and probe the following pins on J13.
  - Pin 1 +15 Vdc  $\pm$ 0.75 Vdc
  - Pin 2 +5.2 Vdc  $\pm$ 0.5 Vdc

[Table1-21](#) shows the amplitude ranges and the corresponding attenuator switch control line voltages. Attenuation is switched in at +3 Vdc  $\pm$ .75 Vdc and switched out at 0 Vdc.

**Table 1-21**

Amplitude Levels	Pin Numbers and Voltages				
	J13-5 40B dB Atten. Step	J13-6 20 dB Atten. Step	J13-7 40C dB Atten. Step	J13-9 10 dB Atten. Step	J13-10 5 dB Atten. Step
+25 to +5.1 dBm	0	0	0	0	0
+5.0 to -4.99 dBm	0	0	0	0	+3
-5.0 to -14.99 dBm	0	0	0	+3	+3
-15.0 to -24.99 dBm	0	+3	0	0	+3
-25.0 to -34.99 dBm	0	+3	0	+3	+3
-35.0 to -44.99 dBm	+3	0	0	0	+3
-45.0 to -54.99 dBm	+3	0	0	+3	+3
-55.0 to -64.99 dBm	+3	+3	0	0	+3
-65.0 to -74.99 dBm	+3	+3	0	+3	+3
-75.0 to -84.99 dBm	+3	0	+3	0	+3
-85.0 to -94.99 dBm	+3	0	+3	+3	+3
-95.0 to -104.99 dBm	+3	+3	+3	0	+3
>-105.0 dBm	+3	+3	+3	+3	+3

6. If the voltages are correct, replace the attenuator.
7. If the voltages are not correct, replace the A26 MID.

## Troubleshooting Harmonic Spurious

Harmonics are multiples of the output frequency. The second harmonic is two times the output frequency at an x dBc down. If the harmonic falls beyond the frequency range of the signal generator, the harmonic is not specified or measured.

To measure harmonics that fall within the signal generator frequency range, set the signal generator and spectrum analyzer to the harmonic frequency and set the signal generator to a specified power level. Measure the output signals peak power level on the spectrum analyzer. This peak power level is the reference level for the harmonic measurement. Turn on Marker Delta, set the signal generator to the fundamental frequency, and measure the power level of the fundamental frequency. The dBc value is the difference between the fundamental peak power level and the harmonic frequency power level.

### 20 GHz Models

Harmonic problems with a fundamental frequency between 500 kHz and 3.2 GHz.

1. Set the signal generator as follows:
  - Frequency: set to harmonic frequency to be measured
  - Amplitude: +10 dBm
  - ALC Off
  - Amplitude Power Search (softkey)
2. Remove the cable on A30 Modulation Filter J3 (W27). Connect the spectrum analyzer to the cable.
3. Set the spectrum analyzer to the harmonic frequency, then press peak search and marker delta.
4. Set the signal generator to the fundamental frequency of the harmonic.
5. Using the delta marker, read the harmonic power level on the spectrum analyzer. Compare the spectrum analyzer reading to the specifications in [Table 1-22](#).

**Table 1-22**

Harmonic Specifications	
< -30 dBc	1 MHz to 2 GHz
-55 dBc	2 GHz to 3.2 GHz

6. If the harmonics do not meet specifications, replace the A8 Output.
7. If harmonic meet specifications reconnect the cable to the A30 Modulation Filter J3 and remove the cable going to A30 Modulation Filter J2 (W31). Connect the spectrum analyzer to the A30 Modulation Filter J2.
8. Set the signal generator and spectrum analyzer to the harmonic frequency, then on the spectrum analyzer, press marker peak search and then delta marker.
9. Set the signal generator to the fundamental frequency of the harmonic.
10. Using the delta marker, read the harmonic power level on the spectrum analyzer. Harmonic level should be  $\leq -55$  dBc.



11. If the harmonic level is  $>-55$  dBc, replace the A30 Modulation Filter.

## 20 GHz Models

Harmonic problems with a fundamental frequency between 3.2 GHz and 20 GHz

1. Set the signal generator as follows:
  - Frequency: set to harmonic frequency to be measured
  - Amplitude: +10 dBm
  - ALC Off
  - Amplitude Power Search (softkey)
2. Remove the cable from the A29 20 GHz Doubler J2. Connect the spectrum analyzer to A29 20 GHz Doubler J2.
3. Set the spectrum analyzer to the harmonic frequency, press marker peak search and then delta marker.
4. Set the signal generator to the fundamental frequency of the harmonic.
5. Using the delta marker, read the harmonic power level on the spectrum analyzer.

**Table 1-23**

<b>Harmonic Specifications</b>	
2nd harmonic	$\leq -15$ dBc
3rd harmonic	$\leq -10$ dBc

6. If harmonics do not meet specification, replace the A29 20 GHz Doubler.
7. If harmonics meet or exceed specification, reconnect the cable to the A29 20 GHz Doubler J2 and remove the cable going to the A30 Modulation Filter J2 (W31). Connect the spectrum analyzer to the A30 Modulation Filter J2.
8. Set the signal generator and spectrum analyzer to the harmonic frequency. On the spectrum analyzer, press marker peak search and delta marker.
9. Set the signal generator to the fundamental frequency of the harmonic.
10. Using the delta marker, read the harmonic power level on the spectrum analyzer. Harmonics should be  $\leq -55$  dBc.
11. If the harmonics do not meet specification, replace the A30 Modulation Filter.

## 40 GHz Models Only

Harmonic problems with a fundamental frequency between 2 GHz and 20 GHz

1. Set the signal generator as follows:
  - Frequency: set to harmonic frequency to be measured
  - Amplitude +10 dBm

- ALC Off
  - Amplitude Power Search (softkey)
2. Remove the cable from the A30 Modulation Filter J2 (W31). Connect the spectrum analyzer to A30 Modulation Filter J2.
  3. Set the spectrum analyzer to the harmonic frequency and press marker peak search and delta marker.
  4. Set the signal generator frequency to the fundamental frequency of the harmonic.
  5. Using the delta marker, read the harmonic power level on the spectrum analyzer. The harmonic level should be  $\leq -55$  dBc.
  6. If the harmonics do not meet specification, replace the A30 Modulation Filter.
  7. If the harmonics meet or exceed specification, reconnect the cable to the A30 Modulation Filter J2 and remove the cable going to A27 40 GHz Doubler output (W30). Connect the spectrum analyzer to the A27 40 GHz Doubler J2.
  8. Set the signal generator and spectrum analyzer to the harmonic frequency. Press marker peak search and delta marker.
  9. Set the signal generator to the fundamental frequency of the harmonic.
  10. Using delta marker, read the harmonic power level on the spectrum analyzer. The harmonics should be  $< -45$  dBc the signal generator's specification.
  11. If the harmonics do not meet specification, replace the A27 40 GHz Doubler.

## Troubleshooting Non-Harmonic Spurious

There are nine different groupings a spur can fall into. The grouping determines what assembly is most likely generating the spur. The procedure for troubleshooting spurs is to identify the grouping based on failing a performance test, checking for loose or broken cables or castings, and replacing the assembly.

**Table 1-24**

Mixing Spurs	These spurs are generated by the mixing products of the RF and IF signals on the A8 Output. The instrument is tuned to a frequency in the Heterodyne-Band (250 kHz to 250 MHz) to measure these spurs.
Power Supply Spurs	These spurs are generated by the power supply switching at a 100 kHz rate. If the test fails for these spurs, change A19 Power Supply.
Offset Reference Spurs	These spurs are generated by the 10 MHz frequency reference on the A7 Reference.
Clock Spurs	Two clocks on the A11 Pulse/Analog Modulation Generator generate these spurs. The first clock is 33.554432 MHz and is used by the numeric synthesizer. The second clock is 100 MHz and is used by the internal pulse generator.
RF and LO Feedthrough Spurs	When the instrument is tuned to a Heterodyne Band (250 kHz to 250 MHz) frequency, the RF and LO feeds through from the mixer on the A8 Output generates spurs on the RF output.
Frac-N Feedthrough	These spurs are generated by the Frac-N frequency coupling onto the low-band signal as it leaves the A6 Frac-N. The spurs then appear at the Frac-N frequency at the RF output.
Sampler Spurs	These spurs are generated on the A5 Sampler by the sampler LO and IF frequencies.
Frac-N 250 MHz Crossing Spurs	These spurs are generated by either the A5 Sampler, A6 Frac-N, or A7 Reference. They occur when a harmonic of the Frac-N frequency equals a harmonic of 250 MHz. The spurs are measured in highband at 133 kHz offset from the CW frequency.
IF 250 MHz Crossing Spurs	These spurs are generated on the A5 Sampler. They are caused by harmonics of the A5 Sampler IF. The spurs are measured in highband at 133 kHz offset from the CW frequency.

---

## Troubleshooting Option UNR Phase Noise

Poor grounds or shielding problems in either the test environment or the measurement system can cause the phase noise measurement to fail. Physical vibration is another common cause of phase noise. Before performing a phase noise measurement make sure all covers are installed, the work surface is free of physical vibrations, and the phase noise system is working properly.

Phase noise failures at specific offsets are fairly predictable. After making sure the measurement accurately reflects a failure, use [Table 1-25](#) to troubleshoot phase noise problems. The troubleshooting procedure consists of assembly substitution.

**Table 1-25**

Frequency Offset	Most Likely Assembly
0 to 100 Hz	A32 High Stability Time Base
100 Hz to 10 kHz	A7 Reference
10 kHz to 100 kHz	A5 Sampler
>100 kHz to 1 MHz	A28 YIG Oscillator or A9 YIG Driver
Frequencies <3.2 GHz	A8 Output
Frequencies >3.2 GHz	A29 20 GHz Doubler or A30 Modulation Filter
Frequencies >20 GHz	A27 40 GHz Doubler

---

**NOTE** In non-Option UNR signal generators, the most likely assemblies and frequency offset are the same except for <100 Hz. In non-Option UNR signal generators the most likely assembly for <100 Hz offset is the A7 Reference.

---

## Overall Description

The overall description provides a functional overview of the Agilent PSG signal generators. Some of the functional blocks discussed are common to many types of instruments, while others are more specific to analog and digital signal generators.

Common functions:

- [A19 Power Supply](#)
- [A18 CPU](#)
- [Input/Output Interface](#)

Specific signal generator functions:

- [Frequency Generation](#)
- [Output Power Level/Automatic Leveling Control](#)
- [Analog Modulation](#) and [Digital Modulation](#)

## A19 Power Supply

### Voltages

The main power supply converts line voltage (120 Vac or 240 Vac) to regulated dc voltages. Some of the required dc voltages are not directly available from the main power supply and are provided by re-regulating one of the main power supply voltages to the required voltage. This regulation can take place on any assembly and is then routed to the required assemblies.

### Line Module

The line voltage connects to the power supply through the A22 Line Module. Because the power supply automatically detects and adjusts to different line voltages, manual line voltage selection is neither necessary nor available. The power supply has an internal line fuse that cannot be replaced. If the fuse opens, the power supply must be replaced.

### Power Supply Thermal Sensors

Two thermal sensors prevent the signal generator from overheating. One sensor is internal to the A19 Power Supply; the other sensor is on the A8 Output. If the signal generator goes into thermal shutdown, the amber and green LEDs on the front panel blink on and off.

## A18 CPU

The A18 CPU controls all activities in the signal generator:

- translating information entered from the front panel keys, LAN, GPIB, or Auxiliary Interface (RS–232) into machine level instructions
- communicating translated instructions on the internal buses
- monitoring critical circuits for problems, such as unlevelled and unlocked conditions
- reporting (on the front panel display) any problems with critical circuits

## Input/Output Interface

### Front Panel

The signal generator accepts inputs through the front panel hardkeys and the display softkeys, and provides outputs on the front panel display, and through the RF output connector and rear panel connectors. Depending on the model, features, and options, the front panel can also contain modulation input/output BNC connectors. In some cases, connectors may be installed but not operational (if the option associated with that connector is not also installed).

When line voltage is present and the signal generator is in standby mode, the amber LED above the power switch lights. When the signal generator is in power–on mode, the green LED (also above the power switch) lights.

**Hardkeys/Softkeys** The front panel has two types of keys:

*Hardkeys* are dedicated to specific functions, entering values for the most commonly used features, and controlling the display's contrast and intensity.

The front panel keypad uses a row and column configuration. Pressing a key makes a connection between a row and column. The row and column information is routed to the A18 CPU where it is interpreted, and the corresponding function executed.

*Softkeys*, located along the display, are used to select the function displayed to the left of the key (on the display). When a softkey is pressed, the displayed function changes.

**A2 Display** An LCD provides information about the instrument's settings and condition. The LCD requires a power supply, lighting, and data:

- The A4 inverter converts dc voltage to the ac voltage required by the display.
- A back–light (a bulb powered by the A4 Inverter) lights the display so that information is visible.
- The A18 CPU generates data, which is routed to the LCD through the A3 Power Switch assembly.

**RF Output Connector** On 20 GHz instruments, the RF output connector is an APC 3.5 male or Type–N (Option 1ED). On 40 GHz instruments, the RF output connector is a 2.4 mm male. Option 1EM moves *all* front panel connectors to the rear panel.

### Rear Panel

The rear panel contains the power line module, LAN, GPIB, RS–232, and A20 source module interface (SMI), scalar interface, and BNC connectors used for sweep interface. Depending on the model, options, and features, additional BNC connectors are provided on the rear panel. In some cases connectors may be installed but not operational if the option associated with that connector is

not installed.

## Frequency Generation

The YIG oscillator generates frequencies from 3.2 to 10 GHz.

Output Frequency	Oscillator Frequency	Path	Notes
< 250 MHz	3.2 to 10 GHz	Low band path, and part of high band path	A6 Frac-N signal is mixed with a 1 GHz signal on the A8 output assembly; the difference is used to generate the lower frequencies.
100 kHz to 3.2 GHz	4 to 8 GHz		Oscillator output is divided by 2/4/8/16 on the A6 Frac-N assembly.
> 3.2 GHz	3.2 to 10 GHz	High band path	For frequencies between 10 and 20 GHz, the oscillator output is doubled. For frequencies between 20 and 40 GHz, the 10 to 20 GHz signal is doubled.

### High Band Path – Frequencies 3.2 GHz and Above

The output of the YIG oscillator (3.2 to 10 GHz) is routed to the A29 20 GHz Doubler microcircuit. Depending on the desired output frequency, the signal is routed either through a bypass circuit (for frequencies <10 GHz), or through a frequency doubler circuit (for frequencies >10 GHz). After the bypass or doubler circuits, the signal is amplified and filtered.

The 20 GHz Doubler output is routed first to either the A30 Modulation Filter (in *analog* models) or the A35 3–20 GHz I/Q Modulator (in *digital* models), and then to the A30 Modulation Filter. The A30 contains amplitude and pulse modulators, amplifiers, and filters. The A35 3–20 GHz I/Q Modulator contains I and Q modulation circuits used to transfer the I/Q information to the RF signal.

In 20 GHz models, the output of the A30 Modulation Filter is routed to the A24 High Band Coupler and A25 High Band Detector, then either through the optional AT1 attenuator to the front panel RF output connector, or directly to the RF output connector.

In 40 GHz *analog* models, the A30 Modulation Filter output is routed to the input of the A27 40 GHz Doubler for frequencies above 20 GHz, and to a bypass switch in the A27 40 GHz Doubler for frequencies up to 20 GHz. The output of the A27 40 GHz Doubler is connected to the A24 High Band Coupler and A25 High Band Detector, to the optional AT1 attenuator, and to the front panel RF output connector.

### Low Band Path – Frequencies Below 3.2 GHz

For frequencies below 3.2 GHz, the YIG oscillator output is tuned between 4 and 8 GHz. The YIG oscillator output is routed to the A29 20 GHz Doubler microcircuit, where a portion of the signal is coupled off and routed to the A6 Frac-N. A divider on the A6 Frac-N divides the 4 to 8 GHz signal to a frequency between 250 MHz and 3.2 GHz. This signal is then routed to the A8 Output assembly where it is amplified, filtered and modulated.

Frequencies below 250 MHz are generated on the A8 Output by mixing the output signal from the A6 Frac-N (between 1000 and 750 MHz) with a 1 GHz LO from the A7 Reference. In *digital* models, the A8 Output also contains the I/Q modulation circuit.

Option 1E6 (Improved Pulse performance below 3.2 GHz) is installed after the A8 Output.

The signal (100 kHz to 3.2 GHz) is routed to the A23 Low Band Coupler/Detector, and then switched into the high band path by a switch in the A30 Modulation Filter microcircuit. From this point, the

low frequency signals flow to the front panel through the high band path.

## Frequency Control

**CW Mode** The A9 YIG Driver, A18 CPU, A7 Reference, A5 Sampler, and A6 Frac-N establish frequency accuracy and stability. This circuitry is commonly referred to as a phase lock loop (PLL).

In CW operation, the A18 CPU programs the A9 YIG Driver pre-tune DAC to output a voltage that coarsely tunes the YIG oscillator to the desired frequency. The A18 CPU also sets the A6 Frac-N and the A5 Sampler to a frequency such that when the A6 Frac-N, A5 Sampler signal, and the YIG oscillator signals are in phase, the output of the phase comparator is 0 volts, and the phase lock loop is at the desired output frequency. When the phases of these two signals (YO feedback and reference) are *not* the same, the output of the phase detector changes to some voltage other than 0 volts.

The phase detector output is then integrated (the integrator voltage is proportional to the frequency error), and routed to the A9 YIG Driver where it is summed with the pre-tune DAC voltage, causing the YIG's output frequency to change. Once the phase of the two signals matches, the phase detector output voltage returns to 0 volts, and the integrator maintains a constant output voltage, holding the YIG output frequency constant.

To perform a phase comparison between the A6 Reference signal and the RF signal coupled off by the A20 Doubler, a sampling function on the A5 Sampler converts the RF (in GHz) to an IF frequency in the MHz range. A 10 MHz signal from the A7 Reference Assembly is used as the reference to the A6 Frac-N VCO (Voltage Controlled Oscillator) to maintain the A6 Frac-N frequency accuracy. The frequency reference for the A7 Reference can be an:

- external 10 MHz signal
- internal standard 10 MHz OCXO (Oven Controlled Crystal Oscillator) on the A7 Reference
- optional high-stability 10 MHz OCXO

In summary:

- The A18 CPU coarse tunes the YIG, and sets the A5 Sampler VCO frequency and the A6 Frac-N VCO frequencies.
- The A5 Sampler and A6 Frac-N VCO frequencies are not fixed, and vary according to the YIG frequency.
- In some modes, the A6 Frac-N's VCO is divided on the A5 Sampler.
- The A5 Sampler converts the RF signal to an IF signal for phase comparison.
- After a phase detector determines the phase difference between the two signals, the phase detector output is integrated. The integrated voltage is summed with the A9 YIG Driver pre-tune DAC voltage, causing the YIG oscillator output frequency to change to the desired frequency.

**Ramp Sweep Mode (Option 007)** The A9 YIG Driver, A18 CPU, A7 Reference and the A6 Frac-N are used in sweep mode, but the A5 Sampler is not. The A9 YIG Driver does the following:

- generates the sweep rate
- sets the start frequency
- generates the sweep ramp
- provides delay compensation
- adjusts the ALC leveling reference for improved power flatness during sweep

The A6 Frac-N contains the phase lock circuitry required to monitor and maintain phase lock during sweep, and it provides a correction voltage to the A9 YIG Driver.



## Output Power Level/Automatic Leveling Control

The output power control circuitry, commonly referred to as the ALC loop, comprises the following:

- Two detectors: the A23 Low Band Coupler/Detector (frequencies  $\leq 2$  GHz) and the A24 High Band Coupler/A25 High Band Detector (frequencies  $> 2$  GHz). Note: this is not the same frequency breakpoint as defined by the low band and high band paths.

The couplers couple off a small portion of the RF signal and route it to the detectors. The detectors convert the RF signal to a dc voltage proportional to the RF power level, and that dc voltage is routed to the A10 ALC.

- An ALC assembly (A10)
- Two ALC modulators

In ALC leveling on (closed loop operation), the output level is detected and a voltage fed back and compared to a reference voltage. The output of the comparator controls the modulator drive current, which controls the output power level. When the detected and reference voltage levels are the same, the modulator drive current remains constant. When the detected and reference levels are not the same, the modulator drive current changes, causing the RF output power to increase or decrease until the reference and detected voltages are the same.

In ALC leveling off (open loop operation), only a reference voltage is used to control the modulation drive current. The comparator output is the sum of the reference voltage and stored calibration data for that frequency point; no feedback is provided. The stored calibration data is correction information stored in the instrument during power level calibration; it adjusts for any losses that occur after the coupler/detector. The reference voltage is generated on the A10 ALC by a DAC, the output voltage of which is the result of the power level set on the front panel.

**Leveling during ramp sweep (Option 007)** In ramp sweep mode, a sweep compensation reference voltage is routed from the A9 YIG Driver assembly to the A10 ALC to improve leveling during sweep operation. The A18 CPU controls the ALC reference correction DAC on the A9 YIG Driver.

## Analog Modulation

The RF can be modulated using either external signals or internal signals from the A11 Pulse/Analog Generator. The A11 Pulse/Analog Generator includes a pulse generator and a numeric synthesizer to provide AM, FM, PM, and pulse modulation capabilities. For better phase modulation control, the internal generator is tied to the A7 Reference 10 MHz.

Internally generated signals up to 1 MHz can be switched to the LF Output BNC on the front panel.

A11 Pulse/Analog output signals are routed as follows:

Modulation Type	Routed to
Amplitude	A10 ALC
Pulse	A30 Modulation Filter and A8 Output
Frequency and Phase	A6 Frac-N

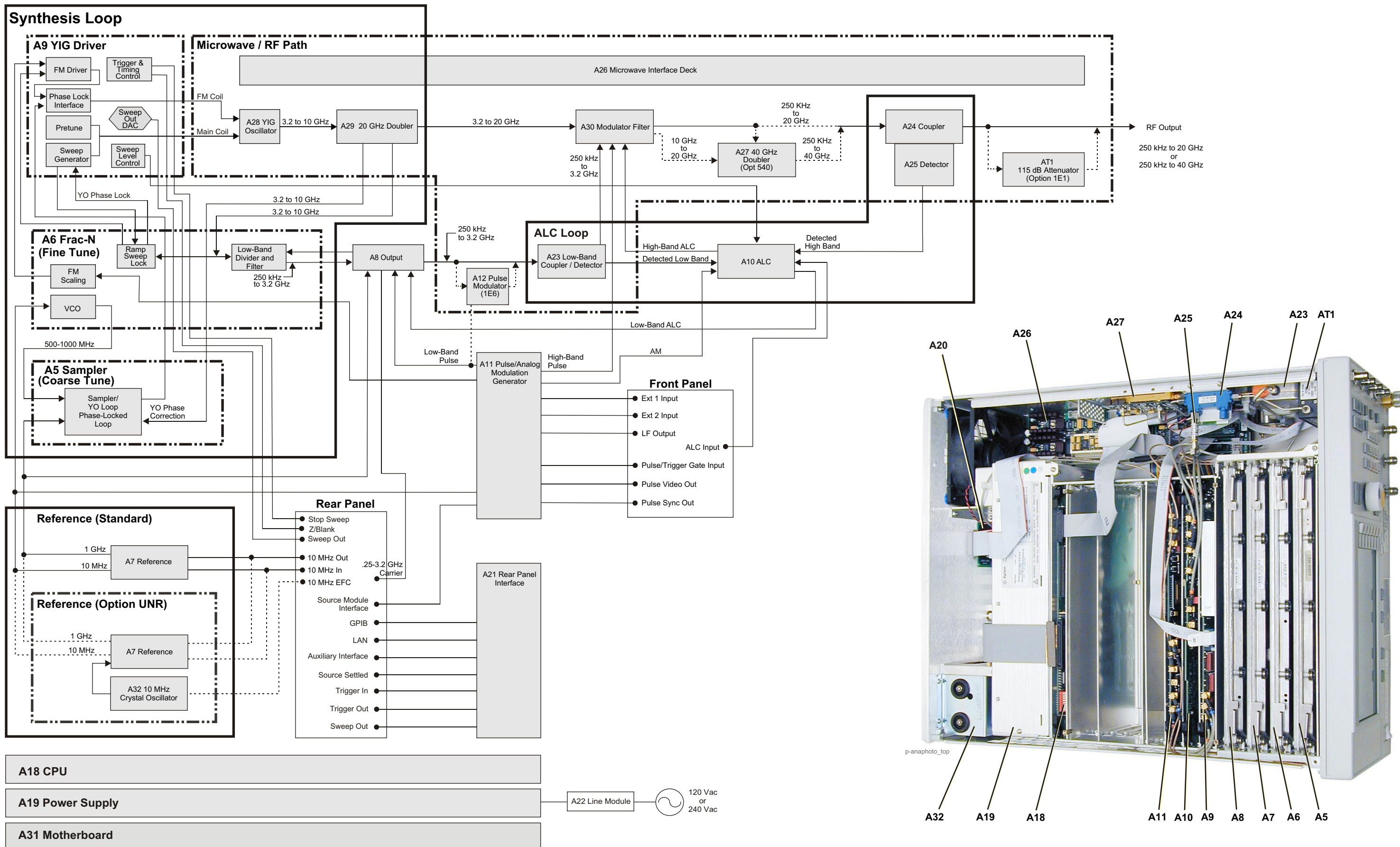
**Improved Pulse Performance <3.2 GHz (Option 1E6)** Option 1E6 installs a pulse modulator between the A8 Output board and A23 Low Band Detector to improve pulse performance below 3.2 GHz. The pulse drive signal is switched from the A8 Output board to the 1E6 assembly.

### **Digital Modulation**

The I/Q modulator circuits in the A8 Low Band, A35 3–20 GHz I/Q Modulator and the A13 I/Q Multiplexer provide digital modulation.

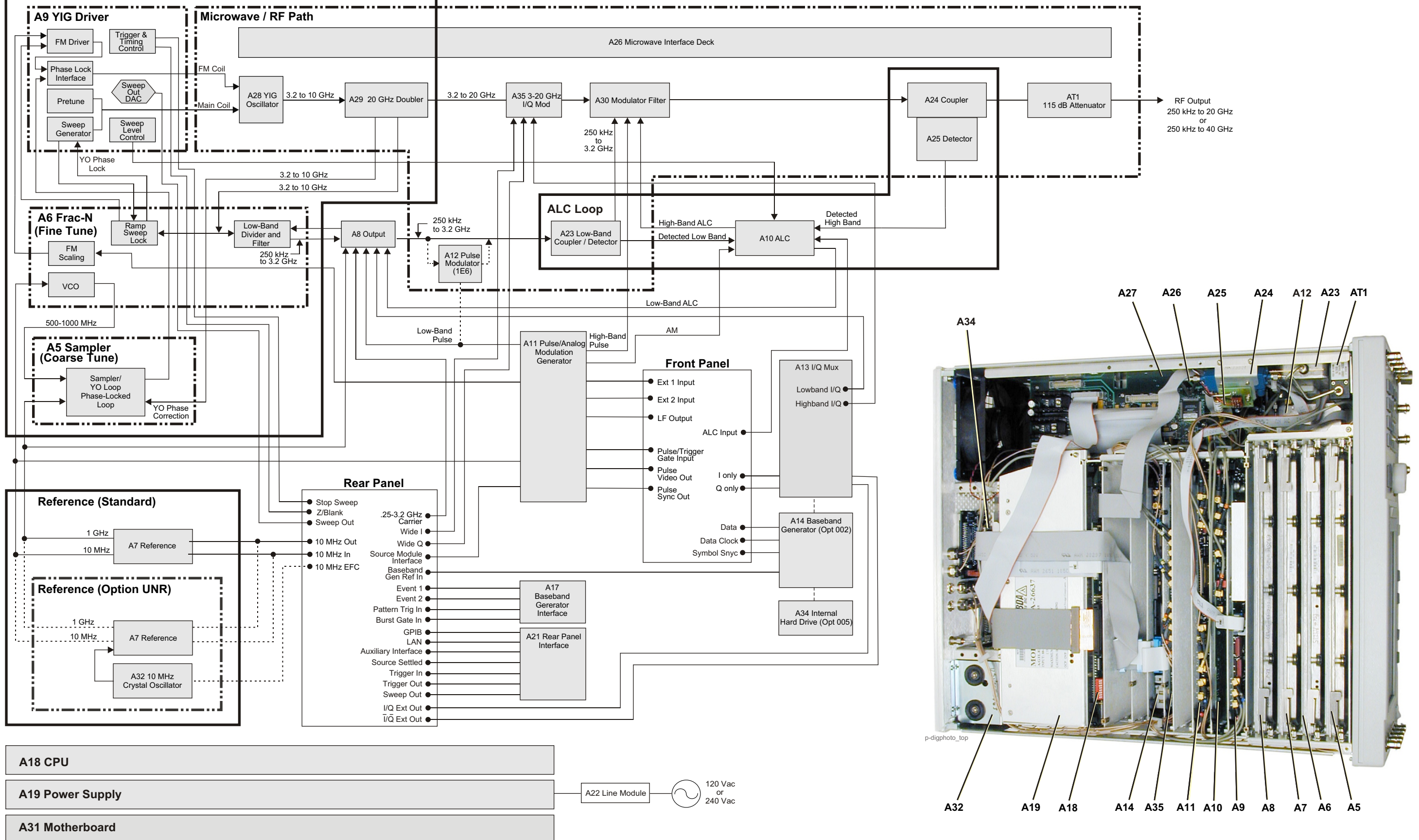
The A13 I/Q Multiplexer provides the circuitry to generate the desired phase shifts and to drive the I and Q modulators. A baseband generator (Option 002) can be added to generate complex waveforms.

**Baseband Generator (Option 002)** Option 002 provides the instrument with a baseband generator, which is used to generate complex waveforms. The A14 Baseband Generator output is routed to the A13 I/Q Multiplexer and then to the I/Q modulators.





# Synthesis Loop



## Reference/Synthesis Loop Description

This description covers generating CW and swept signals at frequencies from 3.2 to 10 GHz. For information on generating other frequencies, see the [“Overall Description” on page 1-85](#).

The Reference/Synthesis Loop establishes the frequency characteristics of the signal generator. Frequency requirements include the following:

- fundamental frequency range generation
- phase noise
- frequency accuracy
- sweep rate (in sweep mode, Option 007)
- swept frequency accuracy (in ramp sweep mode, Option 007)

### Reference/Synthesis Loop Hardware

In *CW* operation, the hardware used includes the A7 Reference, A5 Sampler, A6 Frac–N, A9 YIG Driver, A28 YIG Oscillator (YO), and A29 20 GHz Doubler.

In *sweep* mode, the A5 Sampler is not used.

### CW Mode

The following two basic functions are used to generate an accurate frequency:

- coarse and fine tuning  
The Pre-tune DACs on the A9 YIG Driver provide coarse tuning; the A5 Sampler and A6 Frac–N assembly provide fine-tuning.
- frequency monitoring or feedback

#### *Example (5 GHz CW)*

The A18 CPU sets the A9 YIG Driver Pre-tune DAC to a value such that the YIG oscillator output is approximately 5 GHz (within approximately 3 MHz). The A18 CPU also sets the A5 Sampler VCO and the A6 Frac–N VCO frequencies to the values necessary to generate a 5 GHz YIG Oscillator output.

The A29 20 GHz Doubler receives the output of the YIG oscillator, and couples off and routes a portion of the signal to the A5 Sampler.

On the A5 Sampler, the VCO output samples the 5 GHz from the A29 20 GHz Doubler and converts it to an IF frequency. The IF signal is then filtered and routed to a phase detector.

The output of the VCO on the A6 Frac–N is also routed to the A5 Sampler, where a divide circuit generates the phase detector reference frequency.

At this point, the reference IF and the sampled IF are approximately at the same frequency/phase. When the two signals are in phase, the output of the phase comparator is 0 volts. If the two signals are not in phase, the phase detector generates a voltage proportional to the phase (frequency) difference or error.

The phase detector error voltage is integrated and summed with the YIG oscillator pre-tune voltage on the A9 YIG Driver, fine tuning the YIG oscillator output to exactly 5 GHz.

## Ramp Sweep (Option 007)

The following basic functions are required to generate an accurate sweep in ramp sweep mode:

- coarse and fine tune
- sweep rate control
- sweep generation
- output frequency monitoring or feedback

*Example (start 3.2 GHz, stop 10 GHz, sweep rate 50 ms)*

The A18 CPU sets the A9 YIG Driver Sweep DAC for a +3.2V output, which results in a YIG oscillator output of approximately 3.2 GHz. To sweep the instrument from 3.2 to 10 GHz, a programmable counter on the A9 YIG Driver increments the Sweep DAC's output to +10V.

The speed at which the output of the Sweep DAC changes determines the instrument's sweep rate. The rate of change is controlled by the output frequency of a digitally developed synthesis (DDS) chip on the A9 YIG Driver. The A18 CPU sets the DDS output to a frequency between 0 and 25 MHz, and the DDS output frequency clocks a programmable counter that drives the Sweep DAC rate of change. A low DDS frequency produces a slow sweep rate; a high DDS frequency produces a high sweep rate.

In ramp sweep mode, the A9 YIG Driver Pre-tune DAC is set to 0V. Delay compensation is added to improve linearity, and a fine tune correction from the A6 Frac-N is summed with the Sweep DAC voltage to maintain phase lock. The phase lock correction voltage is generated on the A6 Frac-N by coupling off some of the YIG output frequency in the A29 20 GHz Doubler, and routing it to the A6 Frac-N. On the A6 Frac-N, fixed and programmable dividers (controlled by the A18 CPU) divide the RF signal down to 5 MHz.

Also on the A6 Frac-N, 10 MHz from the A7 Reference is divided down to 5 MHz. The phase of the two 5 MHz signals is compared and integrated. The integrator's output is routed to the A9 YIG Driver and summed with the Sweep DAC (YIG Drive) voltage to maintain phase lock during sweep.

After the A18 CPU has everything set up, the A9 YIG Driver programmable counter is enabled and sweep begins. The A6 Frac-N divide numbers determine how far the A6 Frac-N sweeps before the A18 CPU calculates new divide numbers. The A6 Frac-N divide numbers are updated at filter switch points and at band crossings. During multiple band sweeps, the A9 YIG Driver Sweep DAC, DDS, and delay compensation are updated at band crossings.

## A7 Reference

Clean and stable reference signals are essential to frequency accuracy and low phase noise. In this case, two reference signals are provided:

- 1 GHz (to the A5 Sampler and the A8 Output, for down conversion)
- 10 MHz (to the A6 Frac-N for VCO phase coherency, and the A9 YIG Driver for DDS clock accuracy).

The standard A7 Reference uses a 1 GHz STW Oscillator and 10 MHz OCXO.

The *low phase noise* A7 Reference (Option UNR) uses a 100 MHz VCXO that is multiplied by 10 to achieve 1 GHz, and a high performance 10 MHz OCXO.

## A5 Sampler (CW mode only)

The A5 Sampler contains a microwave sampler used to convert a portion of the YIG oscillator output frequency to an IF frequency for phase comparison.

The A5 Sampler VCO provides the LO input to the RF sampler (the RF is the YIG oscillator signal).

The A5 VCO output frequency (LO input) is set between 618 and 905 MHz. The sampler output is an IF signal between 30 and 64 MHz. The IF signal passes through an 80 MHz low pass filter, eliminating all signals above 80 MHz that might pass through the sampler.

The IF signal is one input to a phase comparator. The second input to the phase comparator is 10 to 80 MHz, and is the result of dividing or mixing the 500 to 1000 MHz signal from the A6 Frac-N VCO. The output of the phase comparator is integrated and summed with the pre-tune voltage on the A9 YIG Driver, fine tuning the YIG oscillator to the desired frequency.

Phase noise is better in FM off mode than in FM on mode. In off mode the A6 Frac-N VCO signal on the A5 Sampler is divided down to get the phase comparator reference frequency of 10 and 80 MHz. In FM on mode, and for FM rates above 230 Hz, phase noise performance degrades because the A6 Frac-N VCO uses a mixer (required for higher FM rates) to get to the reference frequency.

## A6 Frac-N

### CW Mode

The A6 Frac-N can set the YIG Oscillator to any frequency by using a dividing technique that can set the A6 Frac-N VCO signal to any frequency. The A6 Frac-N VCO output is the phase reference for the comparator on the A5 Sampler, so small changes in the divide number result in small changes in the A6 Frac-N VCO output frequency, which result in small changes in the YIG Oscillator frequency.

### FM Mode

FM rates up to 230 Hz are accomplished by combining the FM signal and the A6 Frac-N VCO tune signal to drive the YIG Driver main coil.

FM rates above 230 Hz are accomplished using the FM drive circuit on the A9 YIG Driver to drive the FM coil in the YIG Oscillator.

### Sweep Mode

The A6 Frac-N maintains phase lock in sweep mode by providing the frequency correction voltage; in CW mode the A5 Sampler provides the frequency correction voltage.

The A6 Frac-N downconverts the RF signal from the YIG oscillator, and phase compares it to the phase of a reference signal generated on the A6 Frac-N. The output of the phase comparator is integrated and applied to main or FM coil drive paths using a crossover circuit on the A9 YIG Driver.

On the A6 Frac-N, the RF signal is downconverted to 5 MHz using fixed and programmable dividers. The RF 5 MHz is compared to a 5 MHz reference developed by dividing 10 MHz from the A7 Reference by 2. The difference in phase is integrated and a correction voltage is applied to the crossover circuit on the A9 YIG Driver. By using programmable dividers, the RF side of the comparator can be kept at 5 MHz while the RF frequency sweeps. Because the instrument can maintain phase lock while sweeping over a finite frequency range, the A6 Frac-N divide numbers are changed at filter switch points and band crossings.



## A9 YIG Driver

### CW Mode

The A9 YIG Driver provides the YIG oscillator tune voltage. Coarse tuning of the YIG Oscillator occurs when the A18 CPU sets the pre-tune DACs output voltage to a value that sets the YIG oscillator frequency close to the desired frequency. 3.2 volts out of the pre-tune DAC results in a 3.2 GHz YIG oscillator output.

The A6 Frac-N and A5 Sampler compare the phase of a reference signal and the YIG oscillator frequency, and generate a correction voltage that is summed with the pre-tune voltage on the A9 YIG Driver, which fine tunes the YIG oscillator to the desired frequency. For higher rate FM operation, the FM signal is scaled and the gain calibrated on the A9 YIG Driver before being used to drive the FM coil in the YIG oscillator.

### Ramp Sweep Mode (Option 007)

In sweep mode the A9 YIG Driver provides the tune voltage for the YIG oscillator, generates the sweep voltage, and provides the ALC Reference correction used during sweep.

The A9 YIG Driver has two similar circuits that generate:

- rear panel sweep out signal
- YIG sweep voltage

The hardware in these two circuits is identical, and includes:

- a sweep rate clock that is a digitally developed synthesis (DDS) chip with an output frequency of 0 to 25 MHz. 10 MHz from the A7 Reference maintains the DDS frequency accuracy, and its output frequency clocks the programmable counter at its output rate.
- a programmable counter that can count either up or down; its output increments the sweep DAC.
- a sweep DAC

In the rear panel Sweep Out circuit, the DDS frequency is set so the programmable counter output increments the sweep DAC at the desired sweep rate. The programmable counter in the Sweep Out circuit always increments the sweep out DAC from 0 to +10V.

Because the output frequency can be equal to, a fraction of, or a multiple of the YIG oscillator frequency, the frequency of the DDS in the YIG Drive circuit changes during a sweep so the RF output frequency always sweeps at the desired sweep rate. The amount the programmable counter increments the sweep DAC depends on the required tune voltage. The YIG tunes from the start frequency to either the stop frequency or a band crossing. The Sweep DAC sets the start frequency, and the sweep DAC output voltage directly relates to the YIG output frequency:

- If sweep DAC output = 5V, YIG frequency = 5 GHz
- If sweep DAC output = 10V, YIG frequency = 10 GHz

Signals that are summed with the sweep DAC voltage include:

- delay compensation, which is calculated by the A18 CPU and is dependent on the sweep rate and frequency band
- YIG pre-tune (the pre-tune DAC is always set to 0 volts in sweep mode)
- frequency correction voltage from the A6 Frac-N, which is dependent on the amount of frequency correction required



## **A28 YIG Oscillator (YO)**

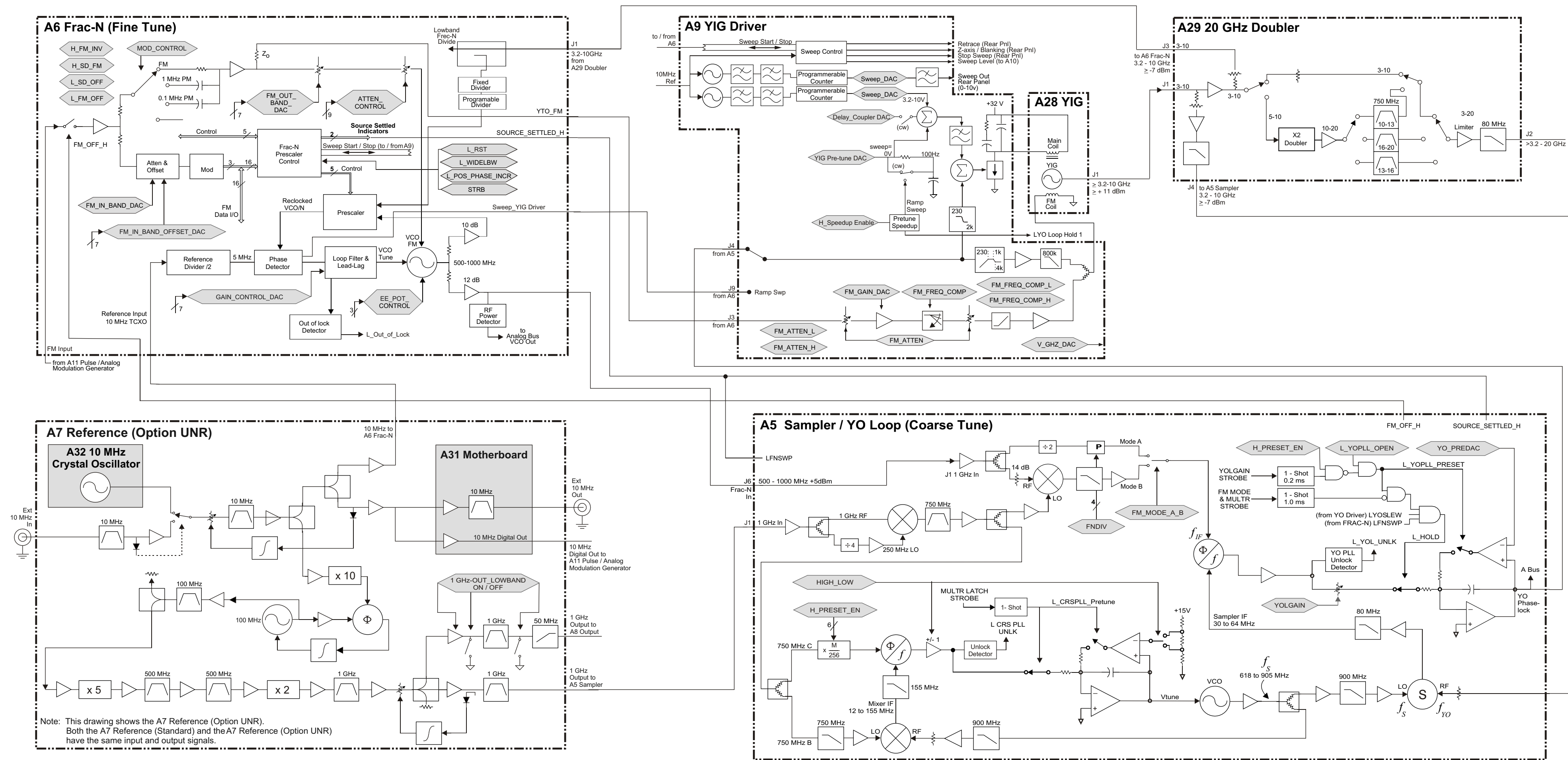
The YIG oscillator output frequency (3.2 to 10 GHz) is controlled by the amount of current through the main and FM coils. The main coil is used to set the frequency, and for FM  $\leq 230$  Hz. The FM coil is used for FM rates  $> 230$  Hz.

## **A29 20 GHz Doubler**

The A29 Doubler provides:

- a thru path for output frequencies from 3.2 to 10 GHz
- two internal couplers that provide a 3.2 to 10 GHz signal to both the A6 Frac-N for phase locking during sweep operation, and to generate frequencies  $\leq 3.2$  GHz; and the A5 Sampler to provide the feedback needed for fine tune correction in CW mode
- a doubler path to generate frequencies from 10 to 20 GHz
- RF signal amplification and filtering





## RF Path Description (Frequency Generation, Level Control, and Modulation)

The RF path can divide, pass through, and multiply the A28 YIG Oscillator (YO) signal to generate the desired RF frequency. Depending on models and options, the RF path includes the hardware for amplitude, pulse, and digital (I/Q) modulation, and to control the RF output power level. The Synthesis /Reference Block Description ([page 1-95](#)) provides information on generating fundamental frequencies of 3.2 GHz to 10 GHz.

All RF signals originate from the A28 YIG Oscillator (YO) output frequencies of 3.2 GHz to 10 GHz. RF output frequencies below 3.2 GHz are generated by dividing the YO signal on the A6 Frac-N and A8 Low Band Output assembly. RF output frequencies between 3.2 and 10 GHz pass through the A29 20 GHz Doubler. RF output frequencies between 10 to 20 GHz are generated by doubling the 5 to 10 GHz YO signal in the A29 20 GHz Doubler. RF output frequencies above 20 GHz are generated by doubling the 10 to 20 GHz signal out of the A29 20 GHz Doubler in the A27 40 GHz Doubler.

### Analog Model Hardware

In analog models, the RF Path comprises the following:

- A29 20 GHz Doubler
- A6 Frac-N
- A8 Output
- A30 Modulation Filter
- A27 40 GHz Doubler (40 GHz models)
- 1E1 Attenuator (if option is installed)
- 1E6 (if fast pulse below 3.2 GHz option is installed)

### Vector Model Hardware

In *addition* to the analog hardware, vector models add the following hardware:

- A35 3 - 20 GHz I/Q Modulator
- A13 I/Q Multiplexer

Some assemblies in vector models differ from those in analog models. Vector models include:

- an A8 Output assembly that includes an I/Q modulator for frequencies below 3.2 GHz
- an A19 Power Supply and A31 Motherboard that can handle increased power requirements
- an A26 Microcircuit Interface Deck and front and rear panels that provide the digital interface
- a baseband generator (Option 002) for internal I/Q waveform generation
- an internal hard drive (Option 005) for internal waveform storage

### A29 20 GHz Doubler

The A29 20 GHz Doubler provides RF signals to the:

- synthesis loop (described [on page 1-95](#))
- low (<3.2 GHz) band RF path (to the A6 Frac-N)
- high (>3.2 GHz) band RF path

Frequencies 3.2 to 10 GHz pass through the A29 20 GHz Doubler. Frequencies 10 to 20 GHz are generated in the doubler by doubling the 5–10 GHz YO signal. Frequencies >3.2 GHz are routed to

the A30 Modulation Filter (in analog models) or to the 3 to 20 GHz I/Q Modulator (in vector models).

## A6 Frac-N

The A6 Frac-N is part of the Synthesis Loop *and* the RF low band path.

The RF signal from the A29 20 GHz Doubler is amplified, filtered, divided (dividers generate RF output frequencies below 3.2 GHz), and then amplified again before being routed to the A8 Output.

The A8 Output provides the A6 Frac-N a pre-level bias voltage to maintain the required RF output level to the A8 Output assembly.

*Troubleshooting note:* To check the A6 Frac-N RF output level, remove the A8 Output from the signal generator while the signal generator is powered on. If the A8 Output is removed while the power is on, the pre-level bias is maintained on the A6 Frac-N, maintaining the RF power level on the A6 Frac-N output.

## A8 Output

### Analog

The A8 Output is in the RF low band path; it provides:

- pre-level bias voltage to the RF output level control on the A6 Frac-N

For frequencies up to 3.2 GHz, the ALC diode controls the RF output power level. Without bias applied to the ALC diode, the output power goes to the maximum level. In closed-loop operation, the A10 ALC uses a negative voltage from both the A23 (< 2 GHz) and A24/25 (>2 GHz) coupler/detectors to control the ALC diode's bias.
- pulse modulation

Pulse modulation (RF pulsed on) is achieved by applying +5 Vdc to the pulse circuitry on the A8 Output. +5 Vdc turns the RF signal on; removing the +5Vdc turns the RF signal off. In instruments without modulation capability that do not have the A11 Pulse/Analog Modulation Generator installed, circuitry on the A8 Output and A30 Modulation Filter biases the pulse diodes on.
- amplitude modulation
- the circuitry to generate under-range frequencies (<250 kHz)

Under-range frequencies are the result of mixing the A6 Frac-N RF signal with a 1 GHz signal from the A7 Reference and using the difference between the two signals for the output. The A8 Output signal passes through the A23 Low Band Coupler/Detector to the A30 Modulation Filter.

### Digital

In addition to providing the analog functionality described above, the A8 Output assembly used in vector models contains an I/Q modulator that is driven with signals from the A13 I/Q Multiplexer to provide I/Q modulation <3.2 GHz. When digital modulation is not selected, the I/Q modulator is bypassed.

## A30 Modulation Filter

Because one function of the A30 Modulation Filter is to switch the high band and low band frequency paths to a common path, the output frequency range of the A30 Modulation Filter is 100 kHz to 20 GHz. For frequencies >3.2 GHz, the A30 Modulation Filter provides amplitude and pulse modulation circuitry, power level control, and filtering. Frequencies <3.2 GHz are simply switched through the A30 Modulation Filter, and are not filtered or modulated.

The high band ALC diode provides level control and amplitude modulation. With no bias applied to the ALC diode, output power is at maximum power level. In pulse operation, the pulse diode must be biased on for the RF signal to pass through. When the A11 Pulse/Analog Modulation Generator is *not* installed:

- If the instrument *does* have modulation capabilities, the pulse diode is turned off and there is no RF output.
- If the instrument *does not* have modulation capabilities, circuitry on the A30 Modulation Filter biases the pulse diode on.

In 20 GHz signal generators, the A30 Modulation Filter output is routed to the A24 High Band Coupler and A25 High Band Detector. In 40 GHz instruments, two outputs from the A30 Modulation Filter are routed to the A27 40 GHz Doubler, as follows:

- One output routes frequencies  $\leq 20$  GHz to a bypass switch.
- One output routes 10 to 20 GHz frequencies to the 40 GHz Doubler circuit.

## A27 40 GHz Doubler (Analog Models Only)

The 40 GHz Doubler generates frequencies >20 GHz. The doubler has two inputs from the A30 Modulation Filter. One input routes frequencies  $\leq 20$  GHz to a bypass switch, and the other input routes 10 to 20 GHz signals to the 40 GHz Doubler. After doubling, band pass filters eliminate unwanted harmonics. The 40 GHz output is routed to the A24 High Band Coupler and A25 High Band Detector.

## A23 Low Band Coupler/Detector, A24 High Band Coupler, and A25 High Band Detector

The coupler couples off a portion of the RF signal so it can be detected and used to monitor the RF output power level. The detector converts the coupled RF signal to a dc voltage that is routed to the A10 ALC, where it is compared to a reference voltage, and integrated. The integrated output provides the ALC diode bias.

The A23 Low Band Coupler/Detector is used for frequencies  $\leq 2$  GHz; the A24 High Band Coupler and A25 High Band Detector are used for frequencies >2 GHz.

In 20 GHz analog and digital instruments, the A24 High Band Coupler and A25 High Band Detector are located after the A30 Modulation Filter; in the 40 GHz analog model, they are located after the A27 40 GHz Doubler. The output of the A24 Coupler is routed to either the optional attenuator or the RF output connector.

Because the A23 Low Band Coupler/Detector is a single unit, the coupler and detector must be replaced together; the A24 High Band Coupler and A25 High Band Detector are separate units that you can replace independently.

### <3.2 GHz Fast Pulse Modulator (Option 1E6)

Option 1E6 provides improved pulse performance below 3.2 GHz. This option is installed in the low band path between the A8 Output and the A23 Low Band Coupler Detector. The pulse drive signal is electrically switched from the A8 Output to the 1E6 assembly, and the pulse diode on the A8 Output is biased on, allowing the RF signal to pass through.

### A35 3–20 GHz I/Q Modulator (Vector Models Only)

The I/Q Modulator, installed between the A28 20 GHz Doubler and the A30 Mod Filter, adds I/Q information to the RF signal. The I/Q Modulator provides the 90° delay circuitry required for I/Q modulation. Inputs to the A35 3–20 GHz I/Q Modulator are from the A13 I/Q Multiplexer. The multiplexer receives inputs from the External I/Q Mod inputs and, if installed, the Option 002 Baseband Generator.

### ALC Loop

The ALC loop maintains power level control and power level accuracy. Level accuracy is achieved by converting a portion of the RF signal to dc, comparing the measured dc to a reference dc voltage, integrating the difference, and using the integrated output to drive the ALC modulation diode. Level control is achieved by adjusting the reference voltage.

The A23 Low Band Coupler/Detector and the A24 High Band Coupler and A25 High Band Detector couple off RF signal and convert it to a dc voltage. Because the coupled signal is a known ratio of the RF output power, it can be used to control the RF output level. On the A10 ALC assembly, the dc is compared to a reference voltage, integrated, and the integrated voltage used to drive the modulator diodes on the A8 Output and A30 Modulation Filter. Temperature sensing circuits maintain level correction over the specified temperature range. In sweep mode, additional compensation is applied to the ALC from the A9 YIG Driver to maintain power flatness during sweep.

### A10 ALC

The A10 ALC assembly provides circuitry for level control and amplitude modulation. In ALC On operation (closed-loop operation), the output signal level is continually monitored and used to adjust the modulator diode output to produce the desired RF output level. In *ALC On* operation, the A10 ALC integrates the difference between the detected voltage and the reference voltage to adjust the modulator diode drive until both voltages agree. The A23 Low Band Coupler/Detector and A24 High Band Coupler and A25 High Band Detector provide the feedback (detected DC) voltage to the A10 ALC. On the A10 ALC, the reference voltage is generated by DACs that are controlled by the CPU. The DACs output voltage is calibrated to the RF output power level.

In *ALC Off* mode (open-loop operation) the feedback path (the RF detected voltage path) is opened, and only the reference voltage is used to set the output power level. With the modulator reference level set to a fixed drive level, and without the output level being monitored, the RF output level can vary from the set power level. In open-loop, the power level can also drift over time with changes in temperature.

In *external leveling* operation, the internal detectors are replaced with an external detector, replacing the internal detectors' voltage with the external detector's voltage. The external detector must be a negative detector to provide the correct polarity for the A10 ALC. In standard instruments, the external leveling operating range is option-dependent, but is either –20 dBm or –15 dBm to maximum power.



Level accuracy is a function of the detector and instrument calibration. Because the instrument is calibrated with internal detectors, external level accuracy depends on the voltage difference between the internal and external detectors at any given RF power level and the difference in linearity between the internal and external detectors.

When *internally* leveled, the ALC circuit is temperature compensated to improve level accuracy over the specified temperature range. Temperature compensation for the A25 High Band Detector consists of a temperature sensing circuit on the A24 High Band Coupler. A resistor pack calibrates the A25 High Band Detector; if the A25 High Band Detector is replaced, a new resistor pack is provided with the new detector, and must be installed on the A24 High Band Coupler. Although rare, unstable level performance above 2 GHz can be the result of problems with poorly soldered resistors on the resistor pack, or with other components in the temperature compensation circuit.

The A23 Low Band Coupler Detector temperature correction circuit is inside the A23 Low Band Coupler Detector package. Because the low band detector and coupler are in one package, they cannot be replaced independently.

## Modulation (AM, FM, $\Phi$ M, and Pulse)

Modulation features apply only to certain models and options of signal generators. The A11 Pulse/Analog Modulation Generator provides modulation signals for AM, FM, pulse, and phase, and SYNC OUT and VIDEO OUT signals. For phase synchronization and modulation accuracy, a dual function generator on the A11 Pulse/Analog Modulation Generator is tied to the 10 MHz reference from A7 Reference. Pulse Input, EXT1, and EXT2 provide external modulation input connections. A front panel low frequency output connector (LF Output) can be selected to output the signal generated by the A11 Pulse/Analog Modulation Generator to drive other instruments.

EXT 1 and EXT 2 inputs contain modulation drive level detection circuits that generate error messages if the signal applied to the input is too small or too large. The input impedance of EXT 1 and EXT 2 can be set for 50 or 600 ohms, and can be configured for dc or ac coupling.

### AM

The AM signal from the A11 Pulse/Analog Modulation Generator is routed to the A10 ALC, where it is summed with the ALC reference voltage to drive the A30 Modulation Filter and A8 Output ALC diodes.

### FM/ $\Phi$ M

The FM/ $\Phi$ M modulation signal is routed from the A11 Modulation Generator to the A6 Frac-N. On the A6 Frac-N:

- FM rates <4 kHz are applied to the pre-scale control circuit and the A6 Frac-N VCO. This generates a change in the pre-scaled drive (feedback from the VCO) to the VCO's phase detector, causing a VCO frequency change.
- FM rates 4 to 100 kHz are applied only to the A6 Frac-N VCO.
- FM rates >100 kHz are routed from the A6 Frac-N to the A9 YIG Driver and applied to the FM coil in the YIG Oscillator.
- For phase modulation, the FM drive signal is routed through an LCR circuit. Other than the LCR circuit,  $\Phi$ M signals are routed the same as FM signals.



## Pulse

Pulse modulation signals from the A11 Pulse/Analog Modulation Generator are routed directly to the A8 Output and the A30 Modulation Filter pulse diodes. Pulse diodes must be biased on to pass RF signals. Circuitry on the A8 Output and A30 Modulation Filter keep the pulse diodes turned on in instruments that do not have modulation capability. Because ALC bandwidth is limited, the ALC circuit can only level pulse widths >1 microsecond. To level pulse widths <1 microsecond, use search mode. Search mode calibration sequencing is as follows:

1. Modulation is turned off.
2. The ALC feedback loop is closed and the RF power leveled.
3. The ALC feedback loop is opened and the integrated output voltage used to drive the ALC diodes is maintained at the level determined during closed loop operation (step 2).

Changes in power level, frequency, or pulse settings cause the signal generator to repeat the search mode leveling procedure and determine a new ALC diode drive level. Because drift in that leveling circuit can occur over time in open-loop operation, it is not recommended to stay in search mode for extended periods of time without closing the loop and refreshing the ALC diode drive voltage.

## Digital Modulation

Digital modulation is produced using portions of the following three major assemblies:

- A14 Baseband Generator (Option 002)
- A13 I/Q Multiplexer
- A8 Output

Together, these assemblies generate and route the baseband signals to the I/Q modulators located on the A8 Output and the A35 I/Q Modulator. The A8 Output modulates carrier signals from 250 kHz to 3.2 GHz, while the A35 I/Q Modulator modulates carrier signals from 3.2 to 20 GHz. The A14 Baseband Generator (Option 002) comprises data generation, burst control, and symbol building circuitry. The output section of the A14 Baseband Generator consists of two 16-bit DACs: one for the I signal and one for the Q signal. The data produced from these I/Q signals is converted to analog, amplified, and filtered before being routed to the A13 I/Q Multiplexer. The I/Q signals are routed from the A13 I/Q Multiplexer to the I/Q modulators, located on the A8 Output and the A35 I/Q Modulator. These I/Q signals modulate the main RF signal.

### A14 Baseband Generator (Option 002)

The A14 Baseband Generator may be used as a dual arbitrary waveform generator, a real time I/Q baseband generator, a noise generator, or a multitone generator. Customer-supplied waveforms can be downloaded into the waveform memory to generate customized formats.

The I/Q bandwidth is 80 MHz for internally-generated signals, and 160 MHz for externally-generated I/Q signals. The A14 Baseband Generator can generate symbol rates of up to 6.25 Msymbol/sec, and has 32 Msamples of waveform memory.

Data is sequenced from waveform memory by the field programmable gate array block (A1-FPGA), passed on to the format builder block (A2-FPGA/Modulator/Filter), and finally to the output section. I and Q DACs at the output convert the digital waveform data to analog. The I and Q output DACs are driven by a sample clock generated by an on-board VCO. The VCO has a frequency range of 200 to 400 MHz. A 10 MHz reference signal from the A7 Reference (or an external 10 MHz reference) can be used to phase-lock the sample clock signal of the DACs.

The Burst Pulse signal from the A14 Baseband Generator goes to the A11 Pulse/Analog Modulation

Generator, and is used to drive the pulse modulators on the A8 Output and A30 Modulation Filter. The Burst Pulse signal is used by the digital modulation formats to synchronize the main RF path and ensure maximum on/off level ratio.

The I and Q output signals are the main signals out of the A14 Baseband Generator. They are also the digital modulation signals that go to the A13 I/Q Multiplexer, and are then routed to the I/Q modulators on the A8 Output and A35 I/Q Modulator.

### **A13 I/Q Multiplexer**

The A13 I/Q Multiplexer receives I/Q input signals from the A14 Baseband Generator, external I/Q input signals from the front panel, and I/Q sense feedback signals from the I/Q modulators on the A8 Output and A35 I/Q Modulator. The A13 I/Q Multiplexer inverts and routes the I and Q signals to the rear panel, where these signals can be used to modulate external equipment. The A13 I/Q Multiplexer also routes the main internal I and Q modulating signal into the I/Q modulators on the A8 Output and A35 I/Q Modulator, which are used to modulate the main RF output.

The A13 I/Q Multiplexer has two identical paths in which to switch incoming I/Q signals. Each path has individual gain control, and can be switched to a summing node. The output of the summing node can be switched to the EXT outputs, and on through more gain control circuitry, and finally out to the A13 Output. I/Q signals are supplied simultaneously to the A8 Output or A35 I/Q Modulator, and to both the inverted and non-inverted external jacks.

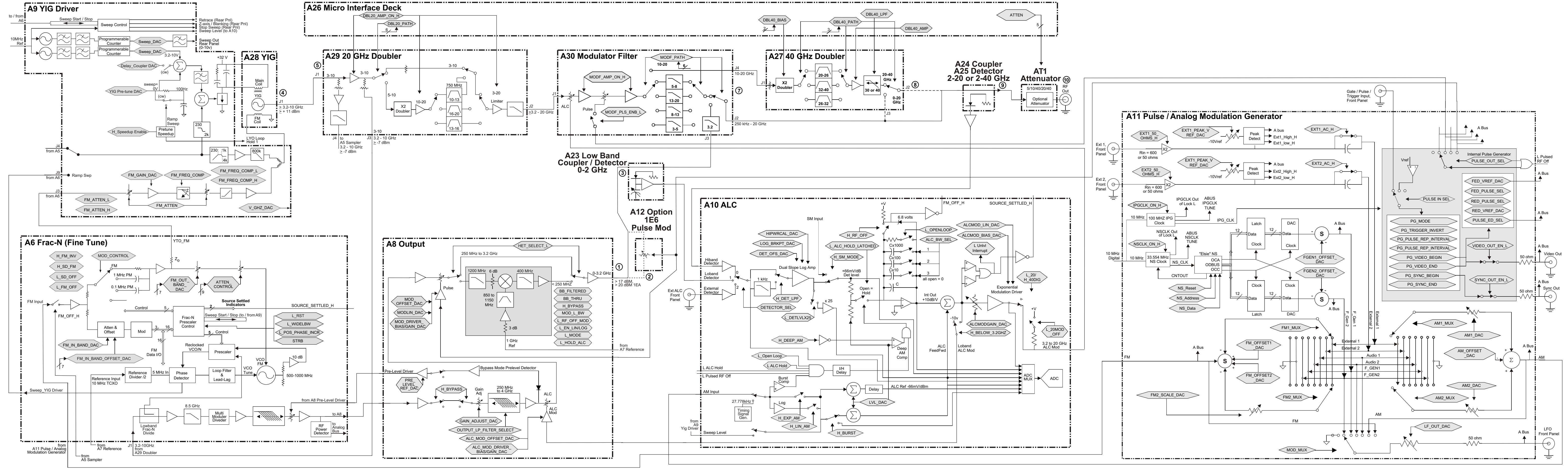
The EXT IN I and EXT IN Q signals enter the A13 I/Q Multiplexer, and can be switched into a 50 or 600 ohm input impedance.

An internal calibration source supplies the levels required to perform independent self tests. This enables the firmware to check the A13 I/Q Multiplexer by setting known levels and reading the various nodes without actually needing an I/Q signal.

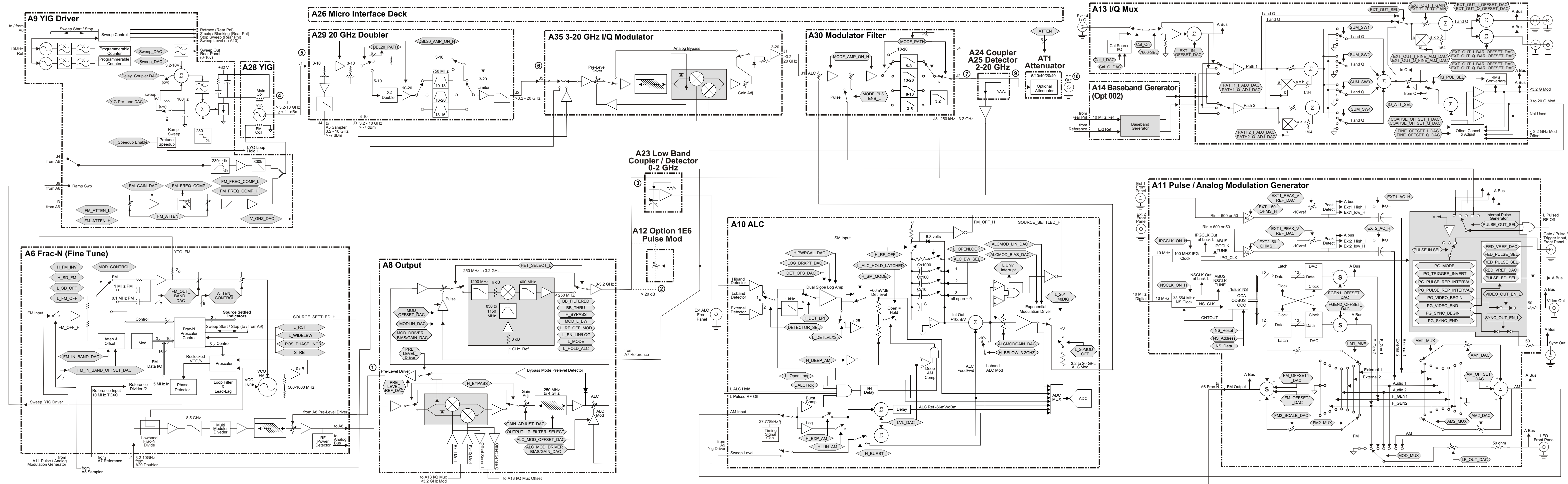
An Offset Sense signal that comes in from the I/Q Modulators on the A8 Output and A35 I/Q Modulator is used to adjust for offsets between the I and Q signals. The Offset Sense signal is compared to the I/Q signal output, and the result is used to control the amplitude; the feedback signal minimizes quadrature and gain errors.

### Approximate Device Gains and Losses

Item #	Device	Gain/Loss	Value (dB)	Analog Instruments	Vector Instruments
1	A8 Output				
	non-1EA	N/A	> 17	✓	✓
	1EA	N/A	> 20		
2	A12 Opt 1E6 Pulse Mod.	Loss	< 3	✓	✓
3	A23 Low Band Coupler	Loss	< 3	✓	✓
4	A28 YO Output	N/A	> 11	✓	✓
5	A29 20 GHz Doubler				
	J1 to J2	Gain	> 1	✓	✓
	J1 to J3 and J4	Loss	< 18		
6	A35 3–20 GHz I/Q Mod.				
	Bypass mode, J5 to J1				
	3.2 to 12.8 GHz	Gain	> 0		✓
	12.8 to 20 GHz	Loss	< 2		
7	A30 Modulator Filter				
	J1 to J2 (non-1EA)	Gain	> 0		
	J1 to J2 (1EA)	Gain	> 8		
	J1 to J4 (non-1EA)	Gain	> 1	✓	✓
	J1 to J4 (1EA)	Gain	> 9		
	J3 to J4	Loss	< 3		
8	A27 40 GHz Doubler				
	J1 to J2 (> 20 GHz)				
	J3 to J2 (< 3.2 GHz)	Loss	< 8	✓	
	J3 to J2 (3.2 to 20 GHz)		< 1		
			< 2.5		
9	A24 High Band Coupler				
	< 3.2 GHz				
	2–20 GHz	Loss	< 2.5	✓	✓
	> 20 GHz		< 0.5		
			< 2.5		
10	AT1 (0 dB step)	Loss	< 2.5	✓	✓







Block Diagram for the Vector RF Path, Service Guide E8251-90259

---

## Self-Test Overview

A group of tests (self-tests) are embedded in the signal generator's firmware that can evaluate the condition of the circuitry on many of the assemblies. Self-tests check hardware performance under controlled conditions, and compare test results to predetermine limits. If the results fall within the limits the signal generator passes. If the results of one or more tests fall outside the limits, the self-test routine evaluates the failures and reports the most independent failure.

Because self-tests are designed to check signal generator *hardware*, the signal generator does not need to be calibrated for self-tests to pass. Self-tests are designed with the philosophy that it is better to pass a defective signal generator than to fail a good one; some failures will pass, rather than be detected and reported. If the signal generator powers on and self-tests can be run, always start troubleshooting by running self-tests and resolving reported problems.

### How self-test works:

1. When the signal generator is tested at the factory, self-test limits are loaded into the A18 CPU memory from devices on each assembly, or from fixed files. Most assemblies contain limit information, while microcircuit limits must be loaded.
2. When the program runs, latches and DACs are set to a known state.
3. An analog mux routes the detected dc signal from the selected rest node to the A18 CPU.
4. The A18 CPU compares the detected dc level to the test limit. If the detected value is within the limits, the A18 CPU reports a pass.
5. If one or more detected values fall outside the limits, the most independent failure is determined and reported.

### Independent failures

An example best illustrates independent failures; in this example, there are three assemblies in a series: A1, A2, and A3. The output of A1 is the input for A2, and the output of A2 is the input for A3. If the output of A1 is bad, A2 and A3 outputs are also bad. If the output of A2 is bad, the output of A3 is also bad. A file in the signal generator contains this dependency knowledge for the signal generator to use to identify the most independent failure. If A1, A2, and A3 self-tests all fail, the signal generator reports A1 as the most independent failure. If A1 passes but A2 and A3 fail, self-test reports A2 as the most independent failure. If A2 passes and A3 fails, self-test reports A3 as the most independent failure. If two independent failures occur, self-test reports only one failure at a time and reports the second failure after the first reported failure is repaired.

Troubleshooting procedures in this chapter are based on the most independent failure, and no lower level information is needed. Although not needed for troubleshooting, the self-test overhead does provide features to view lower level detailed information about the subroutines, and select specific routines to run. These features include:

- Select/Deselect Test
- Select/Deselect All
- View Details
- Run Highlighted Tests
- Run Selected Tests
- When View Details is selected, the highlighted test's measured value, lower, and upper limits are displayed.

---

## Contacting Agilent Technologies

If you have a problem with your signal generator, contact your nearest sales and service office (refer to [page 1-117](#)). When calling, please be prepared with the following information:

**Model Number:** \_\_\_\_\_ **Serial Number:** \_\_\_\_\_

**Firmware Revision:** \_\_\_\_\_ **Installed Options:** \_\_\_\_\_

**Firmware Date:** \_\_\_\_\_

### If you are having problems with an option upgrade

What option(s) are you trying to install: \_\_\_\_\_

Describe the problem: \_\_\_\_\_  
\_\_\_\_\_

### If you suspect a hardware problem

Self-test results:

Pass/Fail: \_\_\_\_\_

Reported self-test failure: \_\_\_\_\_

Error message reported on the front panel:

Unlock: \_\_\_\_\_

Unleveled: \_\_\_\_\_

Other \_\_\_\_\_

Did the instrument fail when it arrived, has it been degrading over time, or was it working for some time and then failed?

Describe the problem: \_\_\_\_\_  
\_\_\_\_\_

What action has been taken: \_\_\_\_\_  
\_\_\_\_\_

### If you are having a problem with performance tests or adjustments

Software revision: \_\_\_\_\_

Name of adjustment or performance test: \_\_\_\_\_

Reported software message: \_\_\_\_\_

Describe the problem: \_\_\_\_\_  
\_\_\_\_\_

### If you are having a problem with an application

Describe what you want to do: \_\_\_\_\_  
\_\_\_\_\_

Describe the problem: \_\_\_\_\_  
\_\_\_\_\_

## Agilent Sales and Service Offices

Sales and service offices are located around the world to provide complete support for your signal generator. To obtain servicing information, contact the nearest Agilent Sales and Service office listed below. For information on ordering parts refer to [“Ordering Information” on page 1-2](#).

By internet, phone, or fax, get assistance with all your test and measurement needs.

**Online assistance:** [www.agilent.com/find/assist](http://www.agilent.com/find/assist)

**United States**  
 (tel) 1 800 452 4844

**Latin America**  
 (tel) (305) 269 7500  
 (fax) (305) 269 7599

**Canada**  
 (tel) 1 877 894 4414  
 (fax) (905) 282-6495

**Europe**  
 (tel) (+31) 20 547 2323  
 (fax) (+31) 20 547 2390

**New Zealand**  
 (tel) 0 800 738 378  
 (fax) (+64) 4 495 8950

**Japan**  
 (tel) (+81) 426 56 7832  
 (fax) (+81) 426 56 7840

**Australia**  
 (tel) 1 800 629 485  
 (fax) (+61) 3 9210 5947

### Asia Call Center Numbers

Country	Phone Number	Fax Number
Singapore	1-800-375-8100	(65) 836-0252
Malaysia	1-800-828-848	1-800-801664
Philippines	(632) 8426802 1-800-16510170 (PLDT Subscriber Only)	(632) 8426809 1-800-16510288 (PLDT Subscriber Only)
Thailand	(088) 226-008 (outside Bangkok) (662) 661-3999 (within Bangkok)	(66) 1-661-3714
Hong Kong	800-930-871	(852) 2506 9233
Taiwan	0800-047-866	(886) 2 25456723
People's Republic of China	800-810-0189 (preferred) 10800-650-0021	10800-650-0121
India	1-600-11-2929	000-800-650-1101



## Packaging a Signal Generator for Return

1. Use the original packaging materials or a strong shipping container that is made of double-walled, corrugated cardboard with 159 kg (350 lb.) bursting strength. The carton must be both large enough and strong enough to accommodate the signal generator and allow at least 3 to 4 inches on all sides of the signal generator for packing material.

---

**CAUTION** Signal generator damage can result from using packaging materials other than those specified. Never use styrene pellets, in any shape, as packaging materials. They do not adequately cushion the instrument or prevent it from shifting in the carton. Styrene pellets cause equipment damage by generating static electricity and by lodging in the signal generator fan.

---

2. Surround the instrument with at least 3 to 4 inches of packing material, or enough to prevent the instrument from moving in the carton. If packing foam is not available, the best alternative is SD-240 Air Cap™ from Sealed Air Corporation (Hayward, CA 94545). Air Cap looks like a pink plastic sheet covered with 1-1/4 inch air-filled bubbles. Use the Air Cap to reduce static electricity. Wrap the instrument several times in the material to both protect the instrument and prevent it from moving in the carton.
3. Seal the shipping container securely with strong, nylon adhesive tape.
4. Mark the shipping container “FRAGILE, HANDLE WITH CARE” to ensure careful handling.
5. Retain copies of all shipping papers.

---

## **2 Assembly Replacement**

## Before You Replace an Assembly

---

**CAUTION** Many of the assemblies in this instrument are very susceptible to damage from electrostatic discharge (ESD). Perform service procedures only at a static-safe workstation and wear a grounding strap.

---

Be sure to review the warning and caution statements described in [Chapter 5, "Safety and Regulatory," on page 5-1](#), prior to replacing an assembly in your signal generator.

## After Replacing or Repairing an Assembly

After you have replaced or repaired an assembly, certain performance tests and adjustments may have to be performed. Please refer to [Chapter 4, "Post-Repair Procedures," on page 5-1](#), for the list of performance tests and adjustments required for each assembly.

## Assemblies That You Can Replace

- "Outer Instrument Cover" on page 2-5
- "Inner Instrument Cover" on page 2-7
- "Front Panel" on page 2-9
- "A1 Keyboard" on page 2-12
- "A2 Display" on page 2-14
- "A2DS1 Display Backlight" on page 2-16
- "A3 Power Switch" on page 2-18
- "A4 Inverter" on page 2-20
- "A5 Sampler, A6 Frac-N, A7 Reference (Standard and Option UNR), and A8 Output" on page 2-22
- "A9 YIG Driver" on page 2-24
- "A10 ALC" on page 2-26
- "A11 Pulse/Analog Modulation Generator" on page 2-28
- "A12 Pulse Modulator Board (Option 1E6)" on page 2-30
- "A13 I/Q MUX (E8267C Models Only)" on page 2-32
- "A14 Baseband Generator (E8267C Models Only)" on page 2-34
- "A17 Baseband Generator Interface (E8267C Models Only)" on page 2-36
- "A18 CPU" on page 2-38
- "A18BT1" on page 2-40
- "A19 Power Supply" on page 2-42
- "Rear Panel (Standard)" on page 2-44
- "Rear Panel (Option 1EM)" on page 2-47
- "A20 SMI (Source Module Interface)" on page 2-50
- "A21 Rear-Panel Interface" on page 2-52
- "A22 Line Module" on page 2-54
- "AT1 115 dB Attenuator" on page 2-56
- "AT1 115 dB Attenuator (Option 1EM)" on page 2-58
- "A23 Low Band Coupler/Detector" on page 2-60
- "A24 20 GHz Highband Coupler (Option 520 Only)" on page 2-62
- "A24 40 GHz Highband Coupler (Option 540 Only)" on page 2-64
- "A25 20 GHz Highband Detector" on page 2-66
- "A25 40 GHz Highband Detector (Option 540 Only)" on page 2-68
- "A25B Highband Detector Bias Board" on page 2-70
- "A26 MID (Microcircuit Interface Deck)" on page 2-72
- "A27 40 GHz Doubler (Option 540 Models Only)" on page 2-74
- "A28 YIG Oscillator" on page 2-76
- "A29 20 GHz Doubler" on page 2-78

**Assemblies That You Can Replace**

- "A30 Modulation Filter (Standard and Option 1EA)" on page 2-80
- "A31 Motherboard (E8247C/57C)" on page 2-83
- "A31 Motherboard (E8267C)" on page 2-86
- "A32 10 MHz Crystal Oscillator (Option UNR)" on page 2-90
- "A33 6 dB PAD" on page 2-92
- "A34 Internal Hard Drive (E8267C Models Only)" on page 2-94
- "A35 3-20 GHz I/Q Modulator (E8267C Models Only)" on page 2-96
- "B1 Fan" on page 2-98

## Outer Instrument Cover

### Tools Required

- T-15 driver
- T-20 driver

### Removal Procedure

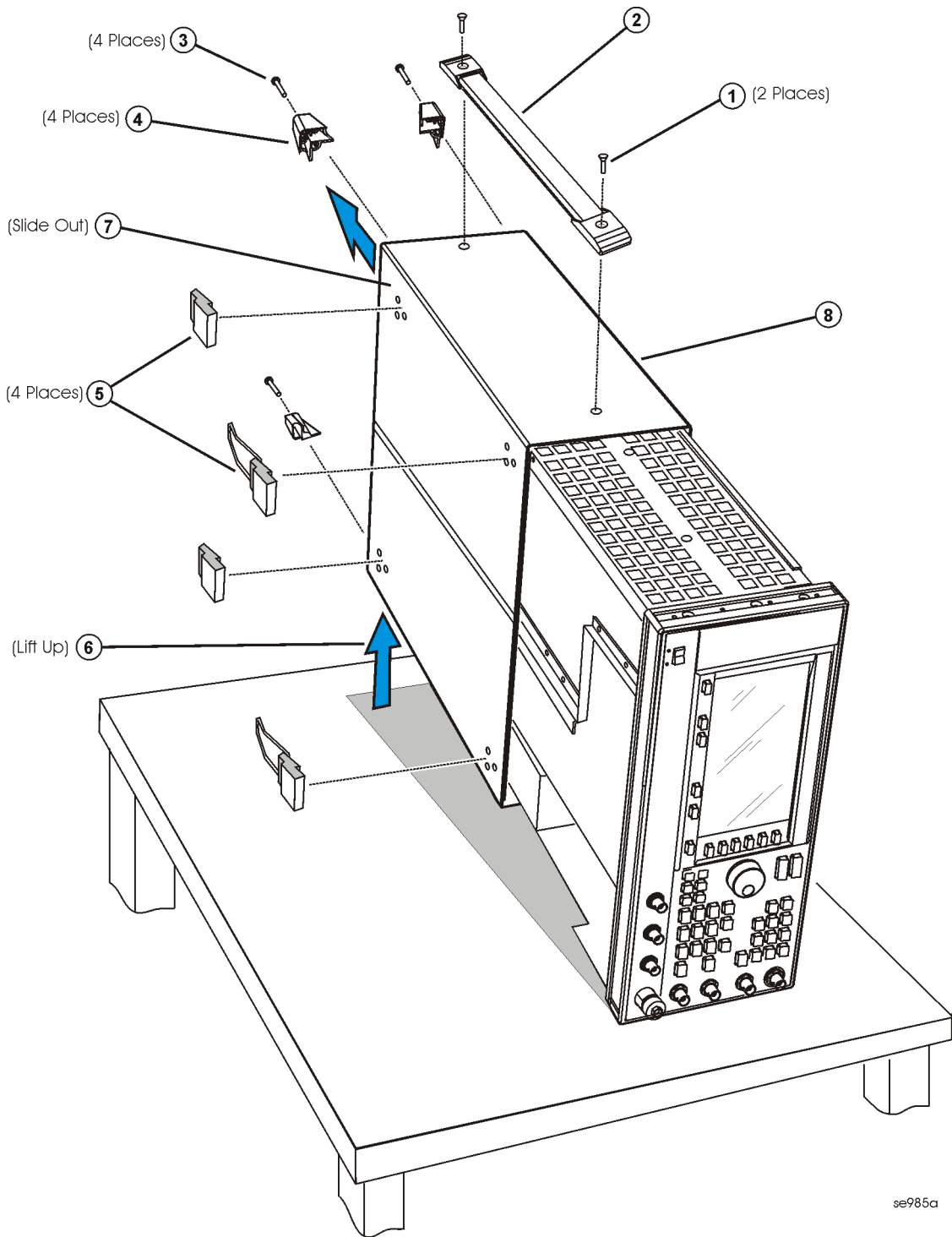
Refer to [Figure 2-1](#) for this procedure.

1. Disconnect the power cord.
2. Using the T-20 driver, loosen and remove the two screws (1) and remove the strap handle (2).
3. Using the T-15 driver, remove the center screws (3) from the four rear-panel feet (4).
4. Remove the four bottom feet (5) from the cover by lifting the tab and sliding the foot toward the tab.
5. Place the signal generator on its side.
6. Tilt the signal generator forward (6) and slide (7) the outer cover (8) back to remove it from the frame.

### Replacement Procedure

- Reverse the order of the removal procedures.
- Torque all T-15 screws to 21 in-lbs.
- Torque all T-20 screws to 21 in-lbs.

**Figure 2-1**      **Outer Instrument Cover Removal**



se985a

## Inner Instrument Cover

### Tools Required

- T-10 driver

### Removal Procedure

Refer to [Figure 2-2](#) for this procedure.

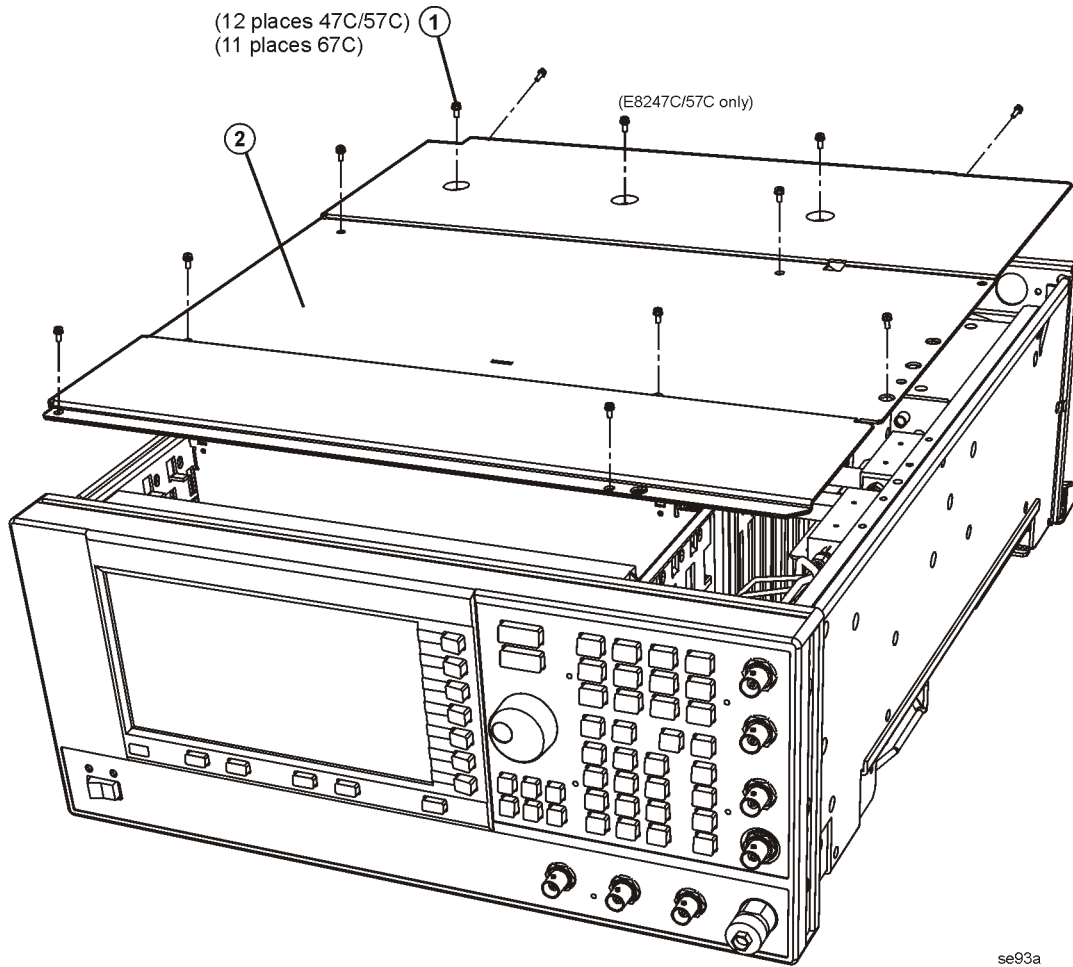
1. Disconnect the power cord.
2. Remove the outer-cover from the signal generator. Refer to "[Outer Instrument Cover](#)" on page [2-5](#).
3. Place the signal generator flat and upright with the front panel facing you.
4. Using the T-10 driver, remove the twelve screws (1) from the inner cover (2).
5. Remove the inner cover.

### Replacement Procedure

- Reverse the order of the removal procedures.
- Torque all T-10 screws to 9 in-lbs.



**Figure 2-2** Inner Instrument Cover Removal



se93a

---

## Front Panel

### Tools Required

- T-10 driver
- T-15 driver
- needle-nose pliers

### Removal Procedure

---

**NOTE** To remove the Front Panel on signal generators with Option 1EM, complete steps 1 through 6 and steps 20 through 23.

---

Refer to [Figure 2-3](#) for this procedure.

1. Disconnect the power cord.
2. Remove the covers from the signal generator. Refer to "[Outer Instrument Cover](#)" on page 2-5 and "[Inner Instrument Cover](#)" on page 2-7.
3. Using the T-10 driver, remove the four screws from the Baseband Generator cover.
4. Remove the side trims that cover the six screws.
5. Using the T-15 driver, remove the six screws (1) from the sides of the frame.
6. Using the T-10 driver, remove one screw on the top (2) and bottom (3) frame.

---

**CAUTION** Before removing the front panel from the signal generator, lift and support the front of the signal generator's frame.

---

7. Slide the front panel over the RF output connector (non 1EM signal generators only).
8. Using the needle-nose pliers, disconnect the following flexible cables:
  - W1 (EXT 1 INPUT) from the A11 Pulse/Analog Modulation Generator J401 (non 1EM signal generators only).
  - W2 (EXT 2 INPUT) from the A11 Pulse/Analog Modulation Generator J402 (non 1EM signal generators only).
  - W3 (LF OUTPUT) from the A11 Pulse/Analog Modulation Generator J403 (non 1EM signal generators only).
  - W4 ALC INPUT) from the A10 ALC J4 (non 1EM signal generators only).
  - W5 (PULSE/TRIGGER GATE INPUT) from the A11 Pulse/Analog Modulation Generator J201 (non 1EM signal generators only).
  - W6 (PULSE VIDEO OUTPUT) from the A11 Pulse/Analog Modulation Generator J203 (non 1EM signal generators only).
  - W7 (PULSE SYNC OUTPUT) from the A11J202 (non 1EM signal generators only).

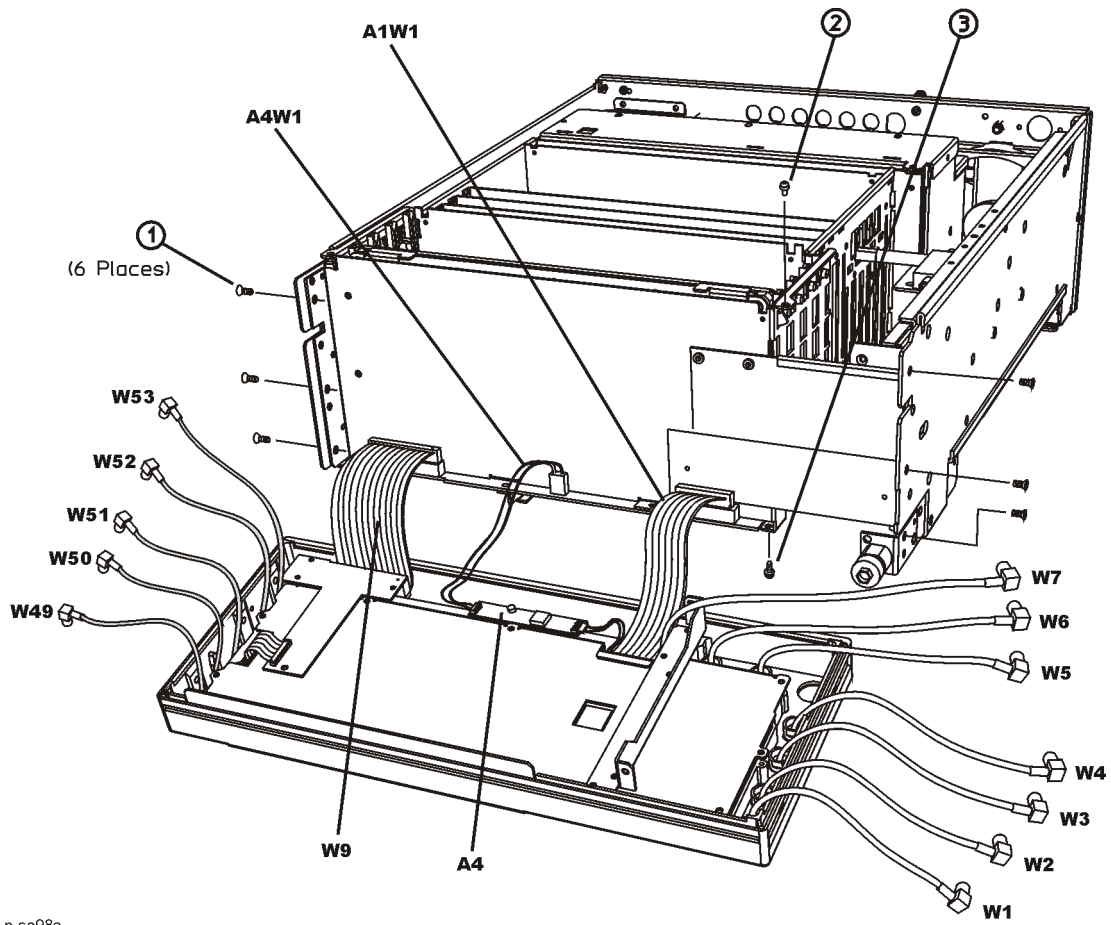
**Front Panel**

- W49 (I IN) from the A35J7 (E8267C only).
  - W50 (Q IN) from the A35J8 (E8267C non 1EM signal generators only).
  - W51 (DATA) from the A31J500 (E8267C non 1EM signal generators only).
  - W52 (DATA CLOCK) from the A31J501 (E8267C non 1EM signal generators only).
  - W53 (SYMBOL SYNC) from the A31J502 (E8267C non 1EM signal generators only).
9. Disconnect the A1W1 display cable from the A31 Motherboard P13.
  10. Disconnect the A4W1 inverter cable from the A31 Motherboard P12.
  11. Disconnect the W9 ribbon cable from the A31 Motherboard P11.
  12. Remove the front panel.

**Replacement Procedure**

- Reverse the order of the removal procedure.
- Torque all T-10 screws to 9 in-lbs.
- Torque all T-15 screws to 21 in-lbs.
- Perform the post-repair adjustments and performance tests that pertain to this removal procedure.

Figure 2-3 Front Panel Removal



p-se98a

## A1 Keyboard

### Tools Required

- T-10 driver

### Removal Procedure

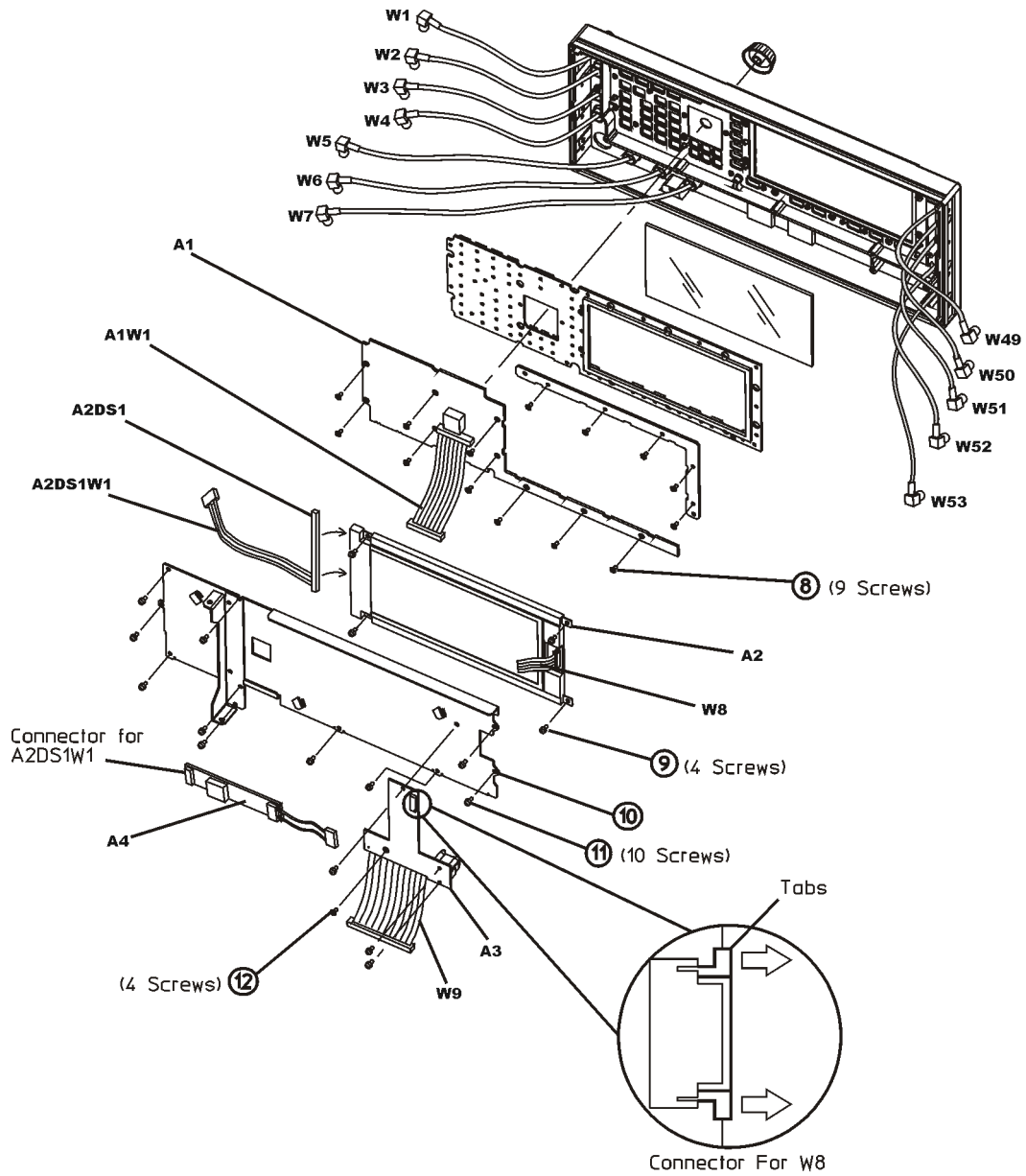
Refer to [Figure 2-4](#) for this procedure.

1. Disconnect the power cord.
2. Remove the front panel. Refer to "[Front Panel](#)" on page 2-9.
3. Disconnect the A2DS1W1 cable from the A4 Inverter.
4. Disconnect the W8 ribbon cable from the A3 Power Switch by lifting the white tabs on the connector.
5. Using the T-10 driver, remove the four screws (12) from the A3 Power Switch.
6. Remove the A3 Power Switch.
7. Using the T-10 driver, remove the ten screws (11) that secure the RFI shielding (10) to the front panel.
8. Remove the metal shielding.
9. Using the T-10 driver, remove the four screws (9) that secure the A2 Display to the front panel.
10. Remove the A2 Display.
11. Using the T-10 driver, remove the nine screws (8) that secure the A1 Keyboard to the front panel.
12. Remove the A1 Keyboard.

### Replacement Procedure

- Reverse the order of the removal procedures.
- Torque all T-10 screws to 9 in-lbs.
- Perform the post-repair adjustments and performance tests that pertain to this removal procedure.

Figure 2-4 A1 Keyboard Removal



p-se97a

## A2 Display

### Tools Required

- T-10 driver

### Removal Procedure

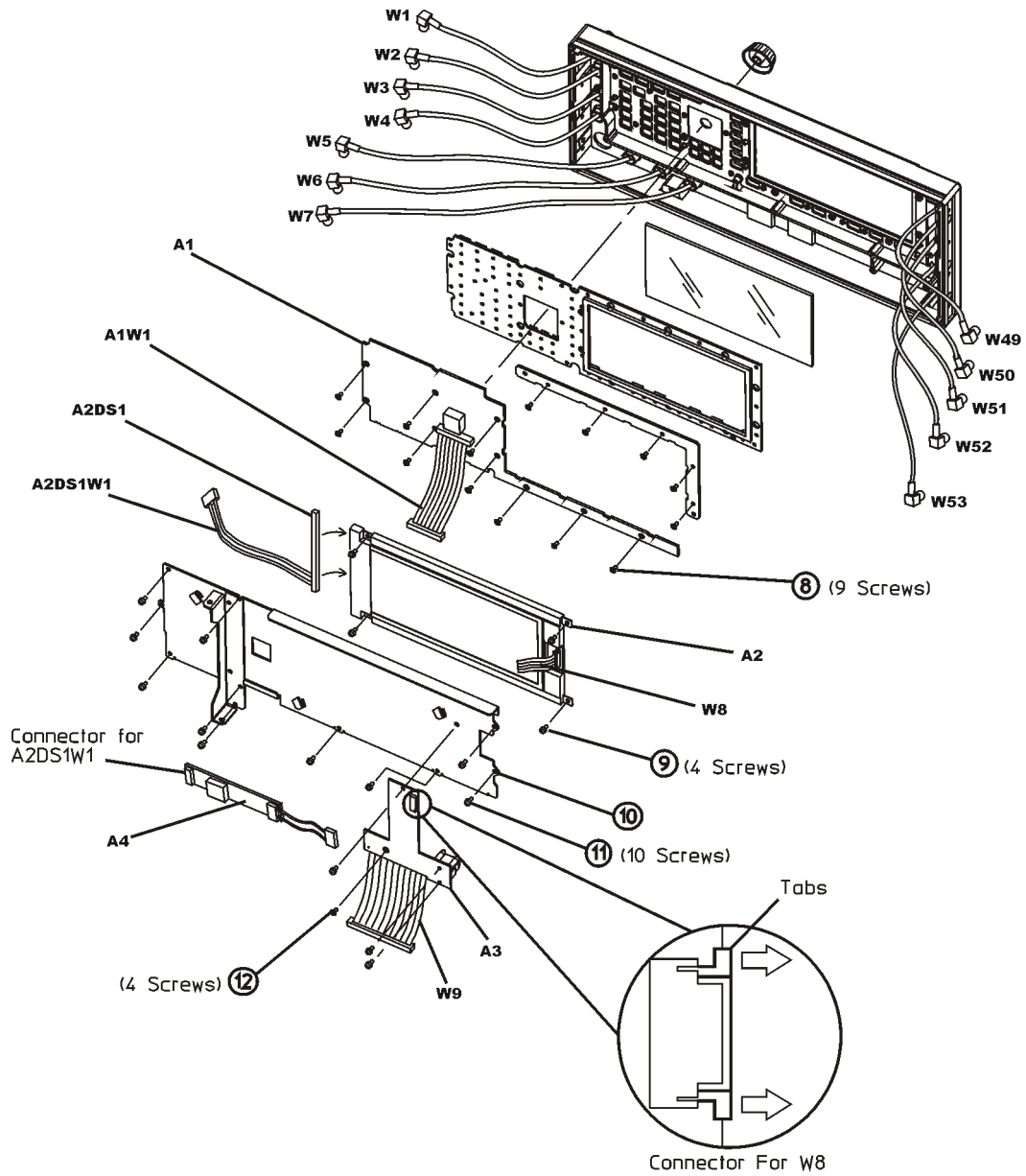
Refer to [Figure 2-5](#) for this procedure.

1. Disconnect the power cord.
2. Remove the front panel. Refer to "[Front Panel](#)" on page 2-9.
3. Disconnect the A2DS1W1 cable from the A4 Inverter.
4. Disconnect the W8 ribbon cable from the A3 Power Switch by lifting the white tabs on the connector.
5. Using the T-10 driver, remove the four screws (12) from the A3 Power Switch.
6. Remove the A3 Power Switch.
7. Using the T-10 driver, remove the ten screws (11) that secure the RFI shielding (10) to the front panel.
8. Remove the metal shielding.
9. Using the T-10 driver, remove the four screws (9) that secure the A2 Display to the front panel.
10. Remove the A2 Display.

### Replacement Procedure

- Reverse the order of the removal procedure.
- Torque all T-10 screws to 9 in-lbs.
- Perform the post-repair adjustments and performance tests that pertain to this removal procedure.

Figure 2-5 A2 Display Removal



p-se97a



## A2DS1 Display Backlight

### Tools Required

- T-10 driver
- small phillips screw driver

### Removal Procedure

Refer to [Figure 2-6](#).

1. Disconnect the power cord.
2. Remove the front panel. Refer to "[Front Panel](#)" on page 2-9.
3. Disconnect the A2DS1W1 cable from the A4 Inverter.
4. Disconnect the W8 ribbon cable from the A3 Power Switch by lifting the white tabs on the connector.
5. Using the T-10 driver, remove the four screws (12) from the A3 Power Switch.
6. Remove the A3 Power Switch.
7. Using the T-10 driver, remove the ten screws (11) that secure the RFI shielding (10) to the front panel.
8. Remove the metal shielding.
9. Using the T-10 driver, remove the four screws (9) that secure the A2 Display to the front panel.
10. Remove the A2 Display.
11. Using a small phillips screw driver, remove the screw (1) that secures the cover (2) over the A2DS1 Display Backlight.
12. Remove the A2DS1 Display Backlight.

### Replacement Procedure

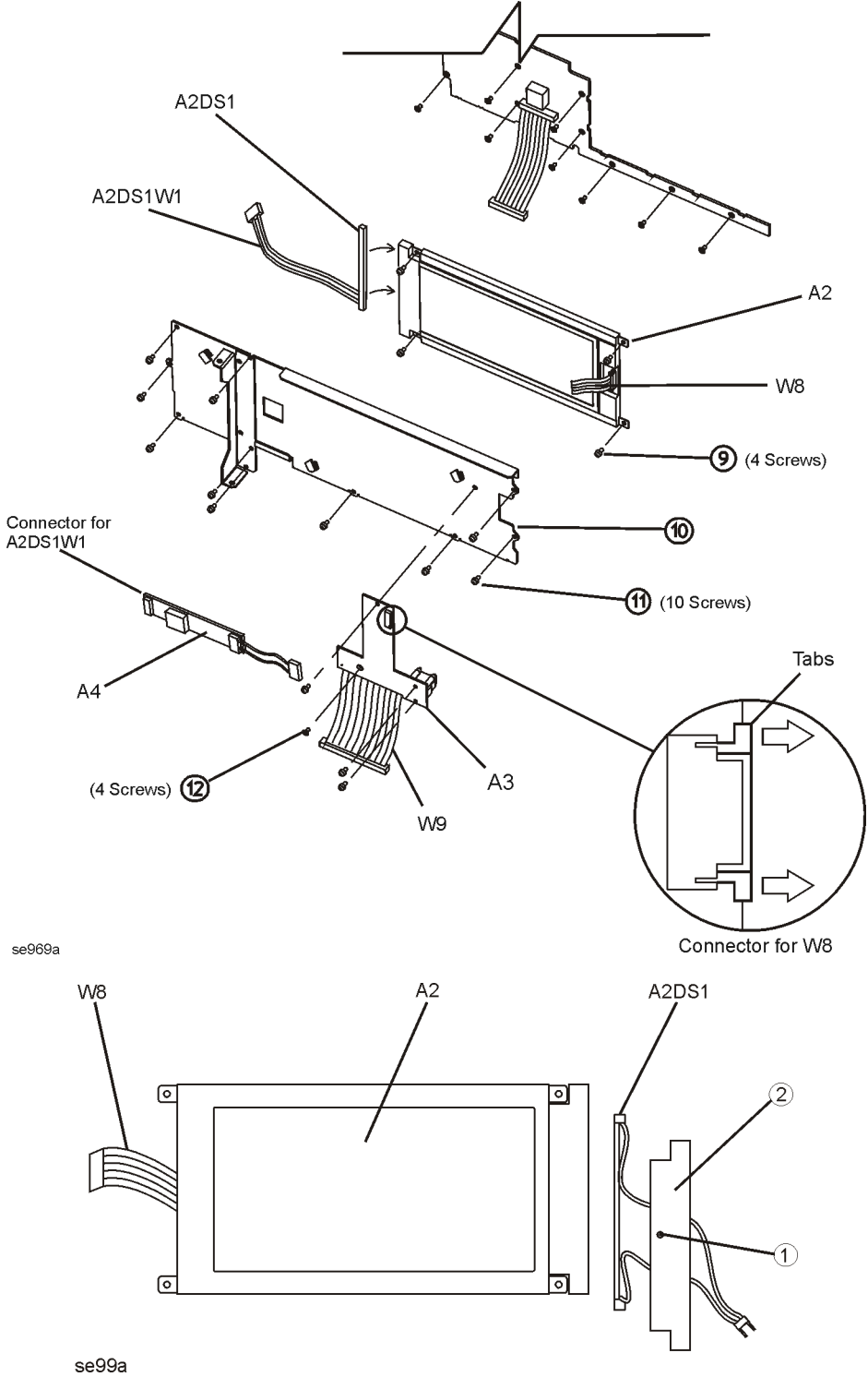
---

**NOTE** When replacing the A2DS1 Display Backlight make sure the reflective paper is behind the light.

---

- Reverse the order of the removal procedure.
- Torque all T-10 screws to 9 in-lbs.
- Perform the post-repair adjustments and performance tests that pertain to this removal procedure.

Figure 2-6 A2DS1 Display Backlight Removal



## A3 Power Switch

### Tools Required

- T-10 driver

### Removal Procedure

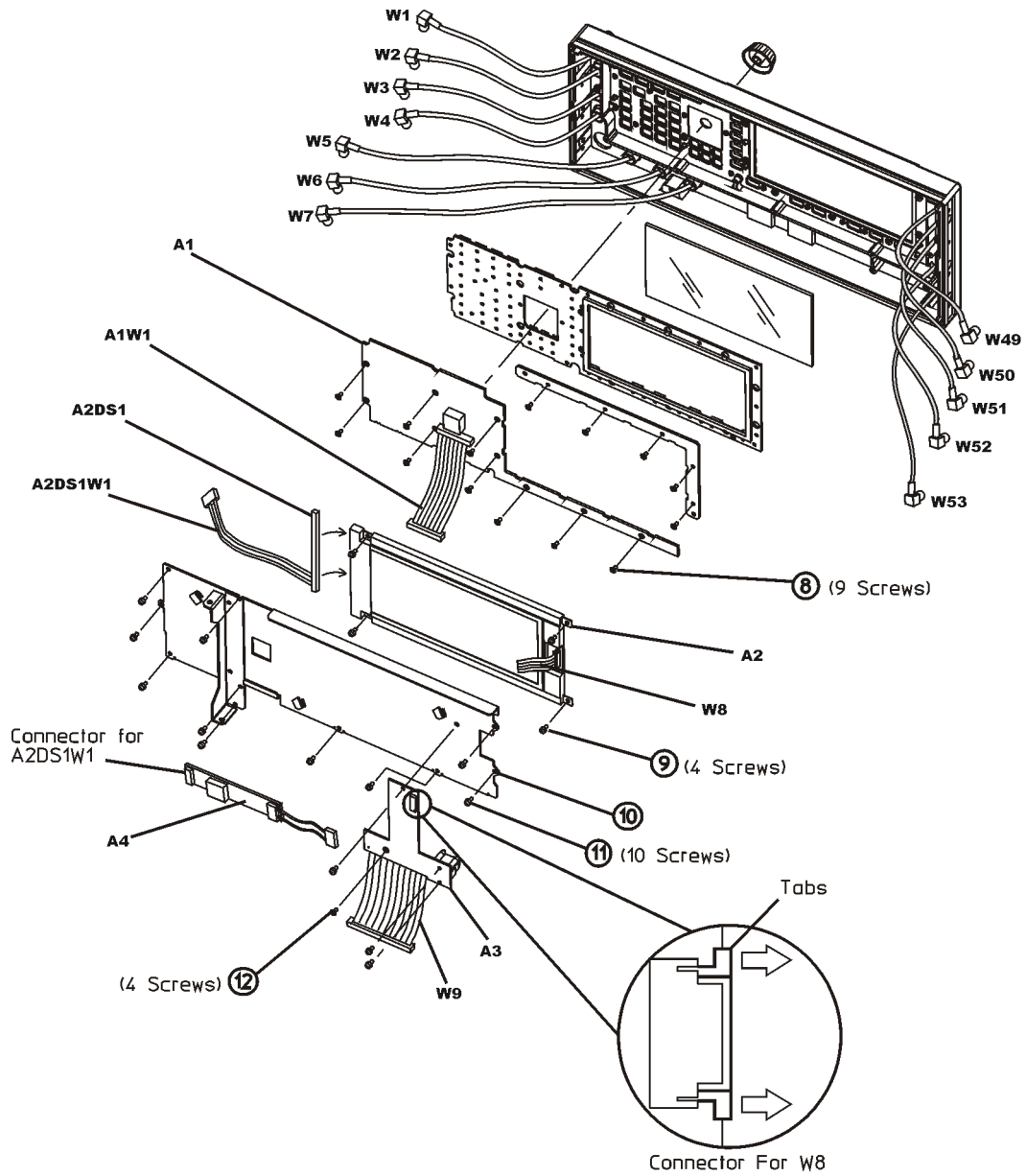
Refer to [Figure 2-7](#) for this procedure.

1. Disconnect the power cord.
2. Remove the front panel. Refer to "[Front Panel](#)" on page 2-9.
3. Disconnect the W8 ribbon cable from the A3 Power Switch by lifting the white tabs on the connector.
4. Using the T-10 driver, remove the four screws (12) from the A3 Power Switch.
5. Remove the A3 Power Switch.

### Replacement Procedure

- Reverse the order of the removal procedure.
- Torque all T-10 screws to 9 in-lbs.
- Perform the post-repair adjustments and performance tests that pertain to this removal procedure.

Figure 2-7 A3 Power Switch Removal



p-se97a

## A4 Inverter

### Tools Required

- none

### Removal Procedure

Refer to [Figure 2-8](#) for this procedure.

1. Disconnect the power cord.
2. Remove the front panel. Refer to "[Front Panel](#)" on page 2-9.
3. Disconnect the A4W1 cable from the A31 Motherboard P12.
4. Disconnect the A2DSW1 cable from the A4 Inverter.

---

**CAUTION** The A4 Inverter is fragile and can be damaged when pulled away from the velcro attachment.

---

5. Remove the A4 Inverter by pulling it away from the front panel.

### Replacement Procedure

- Reverse the order of the removal procedure.
- Perform the post-repair adjustments and performance tests that pertain to this removal procedure.



## **A5 Sampler, A6 Frac-N, A7 Reference (Standard and Option UNR), and A8 Output**

### **Tools Required**

- none

### **Removal Procedure**

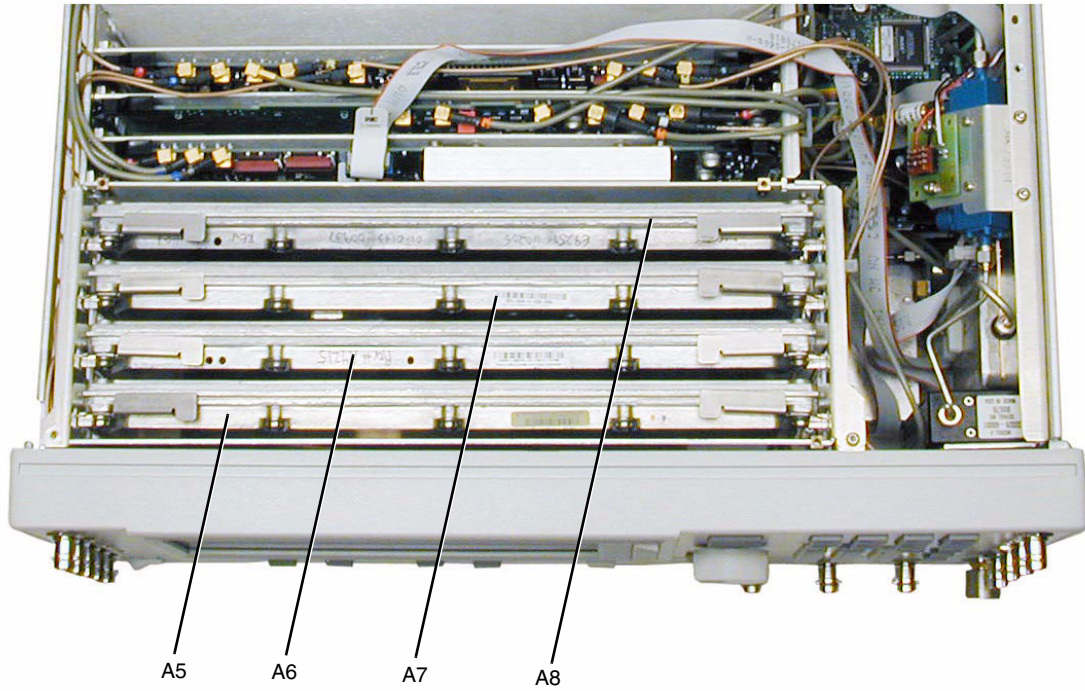
Refer to [Figure 2-9](#) for this procedure.

1. Disconnect the power cord.
2. Remove the covers from the signal generator. Refer to "[Outer Instrument Cover](#)" on page 2-5 and "[Inner Instrument Cover](#)" on page 2-7.
3. Position the signal generator with the front panel facing you.
4. Lift the retention levers and disconnect the board assembly from the A31 Motherboard.
5. Lift the board assembly out of the slot.

### **Replacement Procedure**

- Reverse the order of the removal procedure.
- Perform the post-repair adjustments and performance tests that pertain to this removal procedure.

**Figure 2-9** A5 Sampler, A6 Frac-N, A7 Reference, and A8 Output



p2\_a5



## A9 YIG Driver

### Tools Required

- needle-nose pliers

### Removal Procedure

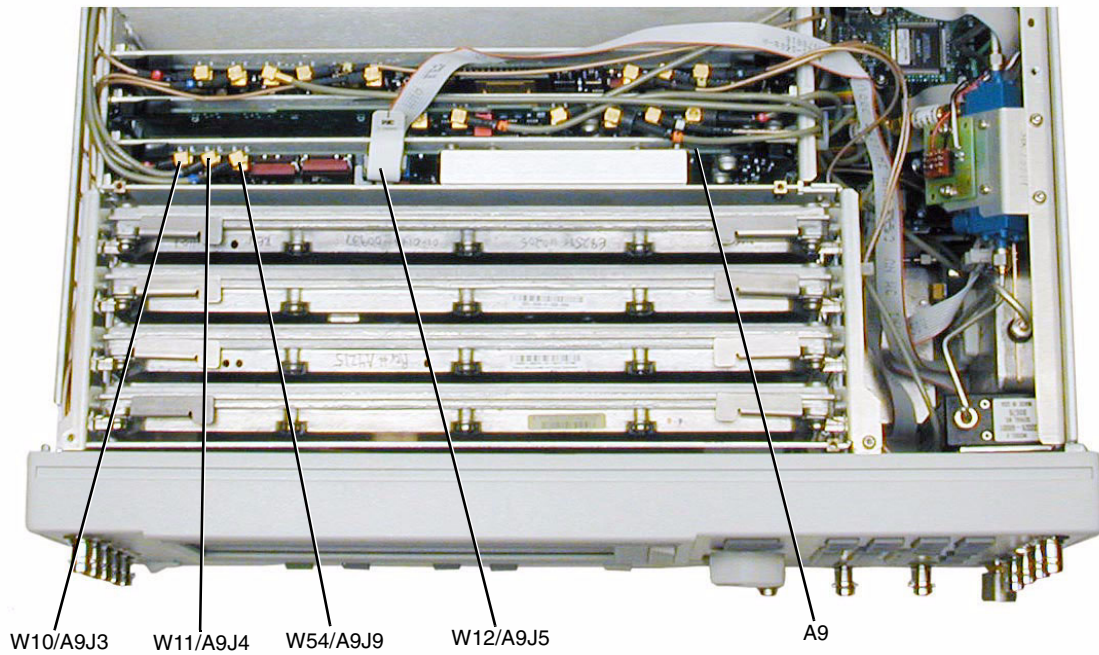
Refer to [Figure 2-10](#) for this procedure.

1. Disconnect the power cord.
2. Remove the covers from the signal generator. Refer to "[Outer Instrument Cover](#)" on page 2-5 and "[Inner Instrument Cover](#)" on page 2-7.
3. Position the signal generator with the front panel facing you.
4. Disconnect the W12 ribbon cable from A9J5.
5. Using the needle-nose pliers, disconnect the following flexible cables:
  - W54 from A9J9
  - W11 from A9J4
  - W10 from A9J3
6. Lift the retention levers and disconnect the A9 YIG Driver from the A31 Motherboard.
7. Lift the A9 YIG Driver out of the slot.

### Replacement Procedure

- Reverse the order of the removal procedure.
- Perform the post-repair adjustments and performance tests that pertain to this removal procedure.

**Figure 2-10**      **A9 YIG Driver**



p2\_a5

## A10 ALC

### Tools Required

- needle-nose pliers

### Removal Procedure

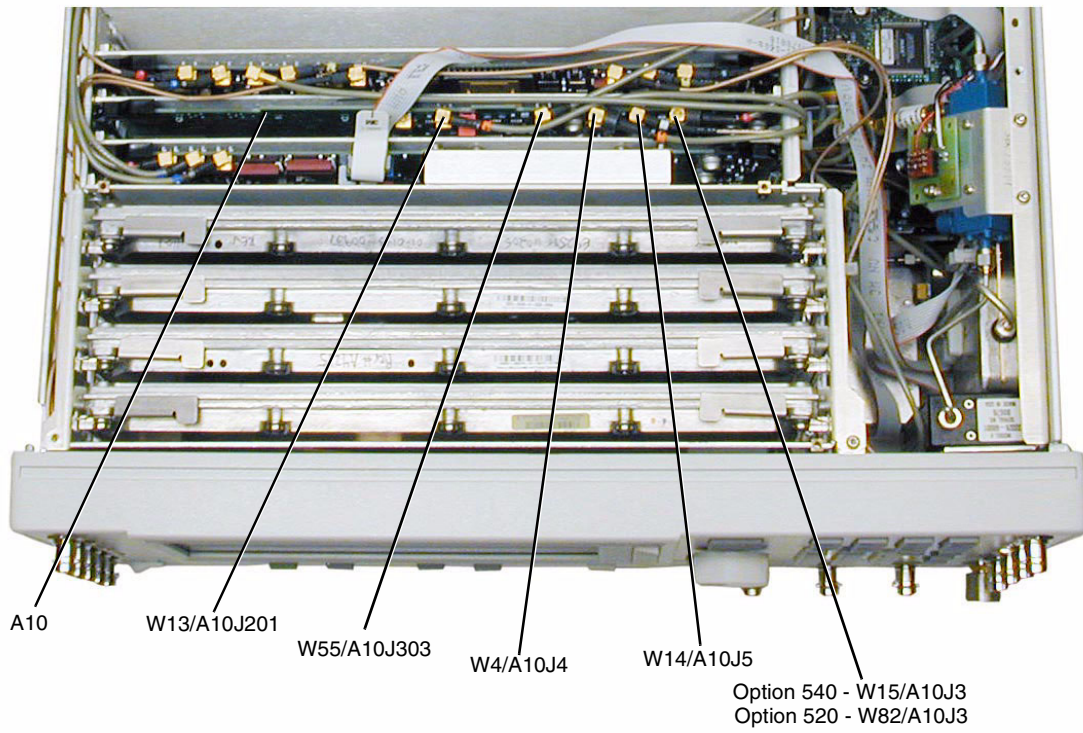
Refer to [Figure 2-11](#) for this procedure.

1. Disconnect the power cord.
2. Remove the covers from the signal generator. Refer to "[Outer Instrument Cover](#)" on page 2-5 and "[Inner Instrument Cover](#)" on page 2-7.
3. Position the signal generator with the front panel facing you.
4. Using the needle-nose pliers, disconnect the following flexible cables:
  - **Option 520** - W82 from A10J3 or  
**Option 540** - W15 from A10J3
  - W14 from A10J5
  - W4 from A10J4
  - W55 from A10J303
  - W13 from A10J201
5. Lift the retention levers and disconnect the A10 ALC from the A31 Motherboard.
6. Lift the A10 ALC out of the slot.

### Replacement Procedure

- Reverse the order of the removal procedure.
- Perform the post-repair adjustments and performance tests that pertain to this removal procedure.

Figure 2-11 A10 ALC



p2\_a5

## A11 Pulse/Analog Modulation Generator

### Tools Required

- needle-nose pliers

### Removal Procedure

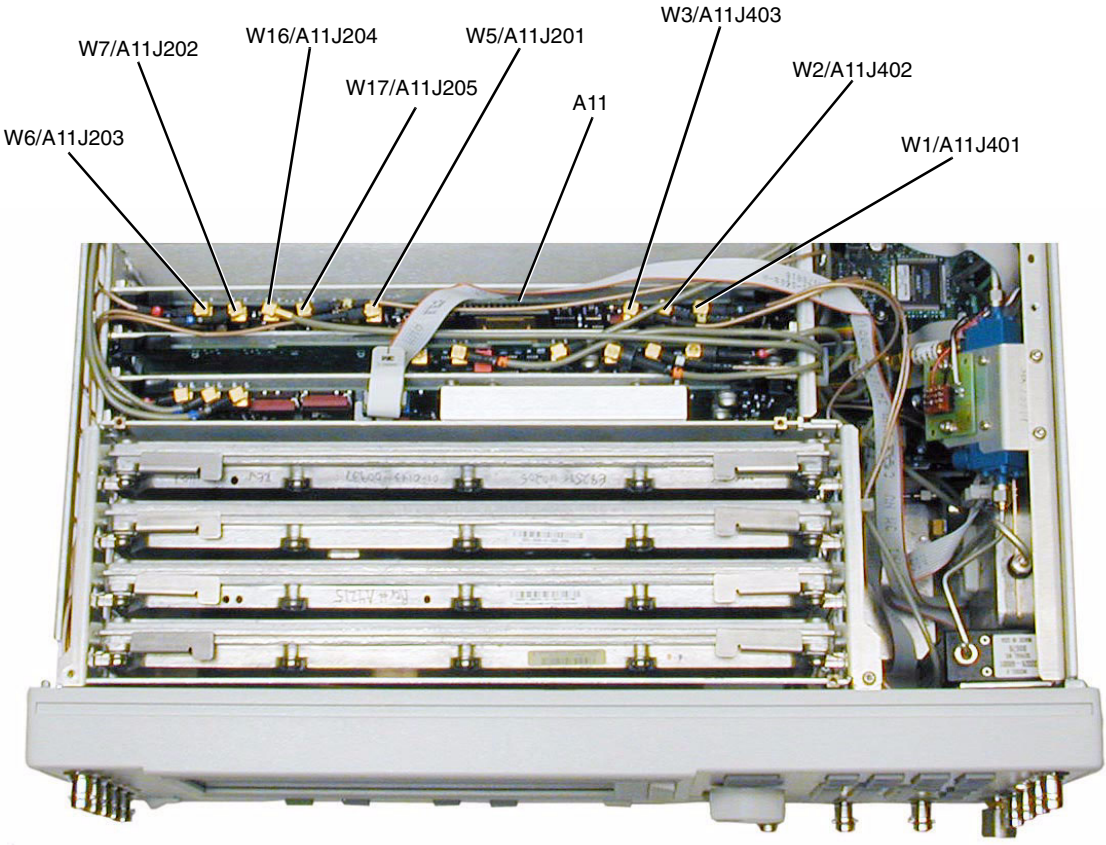
Refer to [Figure 2-12](#) for this procedure.

1. Disconnect the power cord.
2. Remove the covers from the signal generator. Refer to "[Outer Instrument Cover](#)" on page 2-5 and "[Inner Instrument Cover](#)" on page 2-7.
3. Position the signal generator with the front panel facing you.
4. Using the needle-nose pliers, disconnect the following flexible cables:
  - W1 from A11J401
  - W2 from A11J402
  - W3 from A11J403
  - W5 from A11J201
  - W17 from A11J205
  - W16 from A11J204
  - W7 from A11J202
  - W6 from A11J203
5. Lift the retention levers and disconnect the A11 Pulse/Analog Modulation Generator from the A31 Motherboard.
6. Lift the A11 Pulse/Analog Modulation Generator out of the slot.

### Replacement Procedure

- Reverse the order of the removal procedure.
- Perform the post-repair adjustments and performance tests that pertain to this removal procedure.

**Figure 2-12**      **A11 Pulse/Analog Modulation Generator**



p2\_a5

## A12 Pulse Modulator Board (Option 1E6)

### Tools Required

- T-10 driver
- 5/16" open ended wrench

### Removal Procedure

Refer to [Figure 2-13](#) for this procedure.

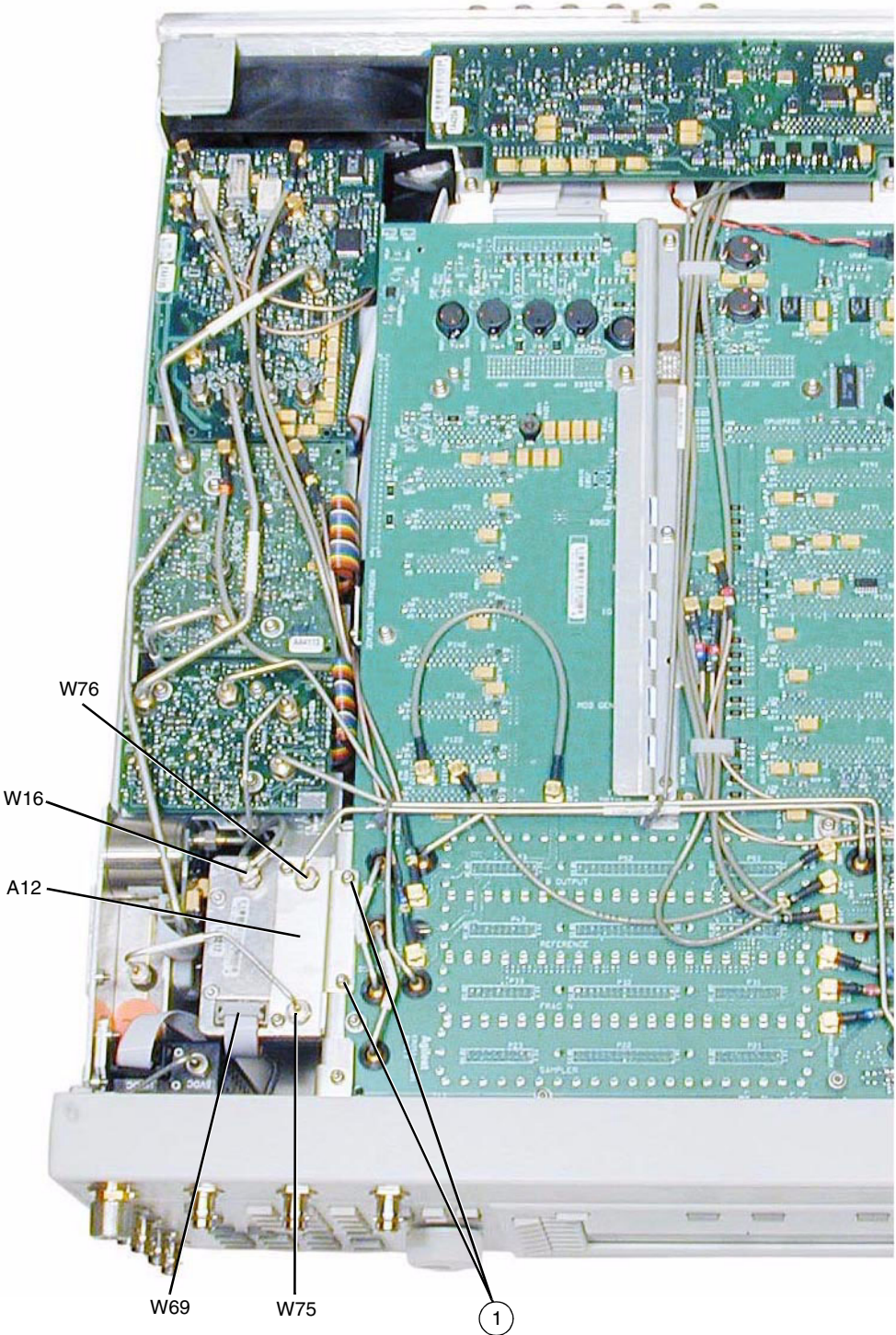
1. Disconnect the power cord.
2. Remove the covers from the signal generator. Refer to "[Outer Instrument Cover](#)" on page 2-5 and "[Inner Instrument Cover](#)" on page 2-7.
3. Position the signal generator so that the A31 Motherboard is facing you and the RF deck is on top.
4. Using the 5/16" open ended wrench, disconnect the W16, W75, and W76 RF cables from the A12 Pulse Modulator Board.
5. Disconnect the W69 ribbon cable from the A12 Pulse Modulator Board.
6. Using the T-10 driver, remove the two screws (1) that attach the A12 Pulse Modulator Board to the main chassis.
7. Remove the A12 Pulse Modulator Board from the RF deck.
8. Using the T-10 driver, remove the sheet metal from A12 Pulse Modulator Board.

### Replacement Procedure

- Reverse the order of the removal procedure.
- Perform the post-repair adjustments and performance tests that pertain to this removal procedure.



Figure 2-13 A12 Pulse Modulator Board (Option 1E6)





## A13 I/Q MUX (E8267C Models Only)

### Tools Required

- T-10 driver
- 5/16" open ended wrench
- needle-nose pliers

### Removal Procedure

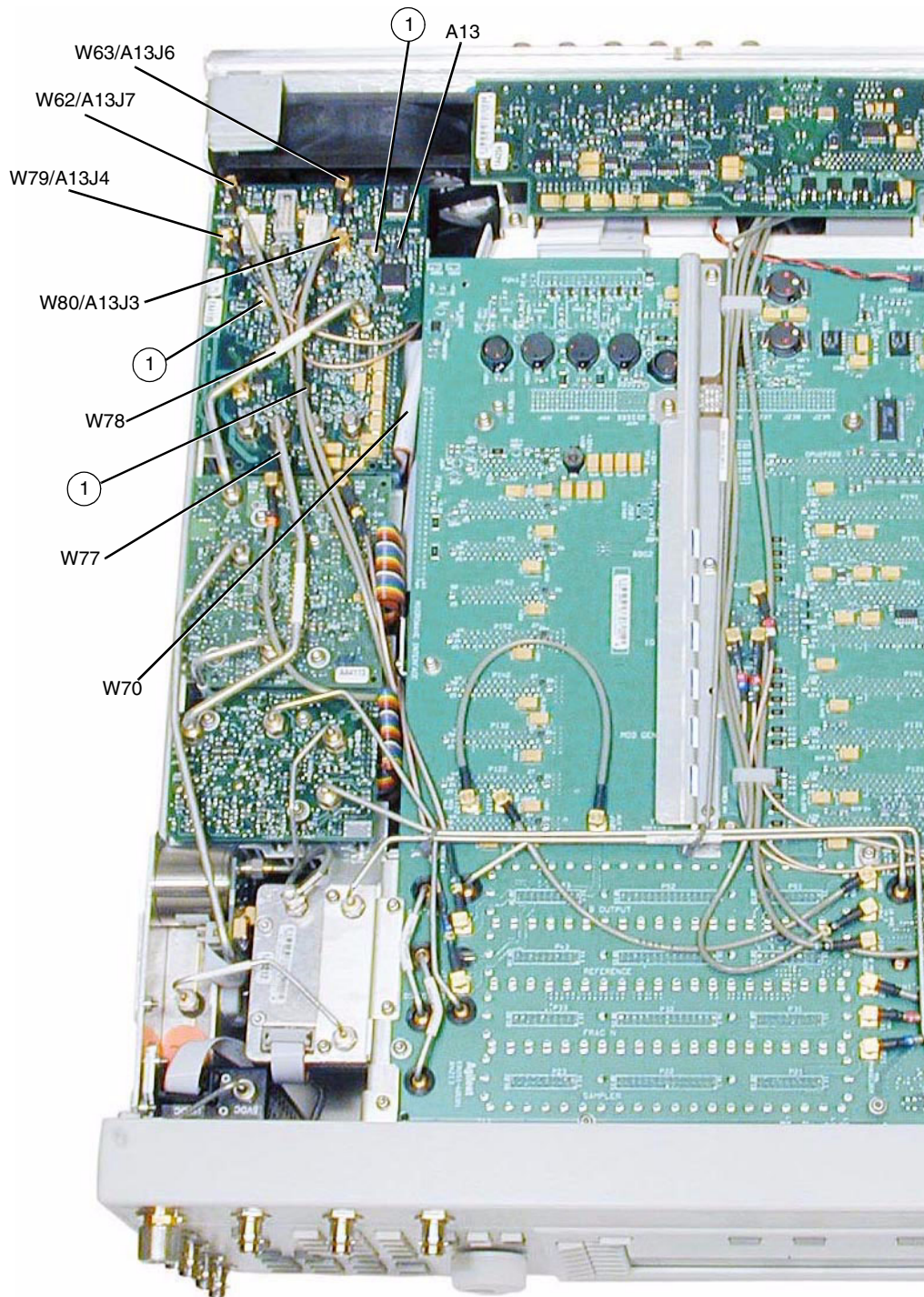
Refer to [Figure 2-14](#) for this procedure.

1. Disconnect the power cord.
2. Remove the covers from the signal generator. Refer to "[Outer Instrument Cover](#)" on page 2-5 and "[Inner Instrument Cover](#)" on page 2-7.
3. Position the signal generator with the A31 Motherboard facing you and the RF deck on top.
4. Using the 5/16" open ended wrench, disconnect the W77 RF cable from the A13 I/Q MUX.
5. Using the 5/16" open ended wrench, disconnect the W78 RF cable from the A13 I/Q MUX.
6. Using the needle-nose pliers, disconnect the following flexible cables:
  - W80 from A13J3
  - W79 from A13J4
  - W62 from A13J7
  - W63 from A13J6
7. Using the T-10 driver, remove the three screws (1) that attach the A13 I/Q MUX to the RF deck.
8. Disconnect the W70 ribbon cable from the A13 I/Q MUX.
9. Remove the A13 I/Q MUX from the RF deck.

### Replacement Procedure

- Reverse the order of the removal procedure.
- Torque all T-10 screws to 9 in-lbs.
- Torque all RF connectors to 8 in-lbs.
- Perform the post-repair adjustments and performance tests that pertain to this removal procedure.

**Figure 2-14**      **A13 I/Q MUX**



## A14 Baseband Generator (E8267C Models Only)

### Tools Required

- needle-nose pliers

### Removal Procedure

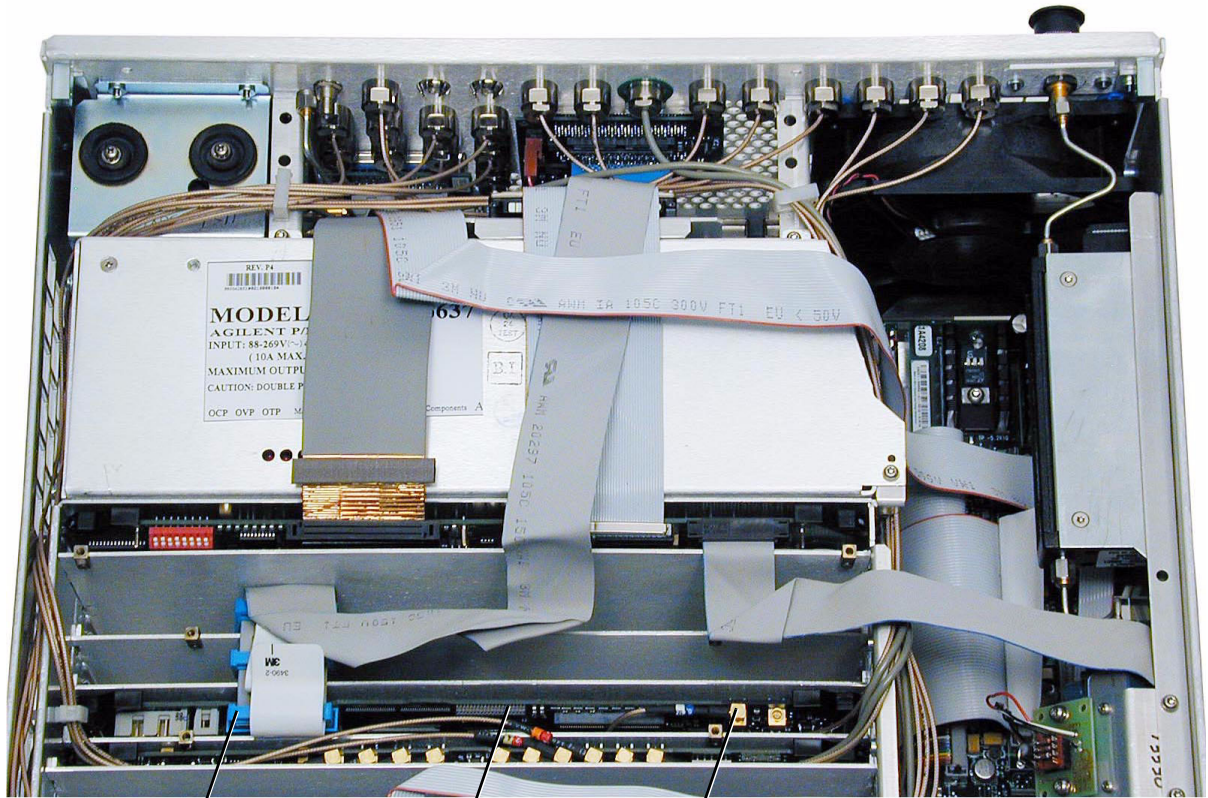
Refer to [Figure 2-15](#) for this procedure.

1. Disconnect the power cord.
2. Remove the covers from the signal generator. Refer to "[Outer Instrument Cover](#)" on page 2-5 and "[Inner Instrument Cover](#)" on page 2-7.
3. Position the signal generator with the front panel facing you.
4. Using the T-10 driver, remove the four screws from the Baseband Generator cover.
5. Using the needle-nose pliers, disconnect the W65 flexible cable from A14J800.
6. Disconnect the W64 ribbon cable from A14J13
7. Lift the retention levers and disconnect the A14 Baseband Generator from the A31 Motherboard.
8. Lift the A14 Baseband Generator out of the slot.

### Replacement Procedure

- Reverse the order of the removal procedure.
- Perform the post-repair adjustments and performance tests that pertain to this removal procedure.

Figure 2-15 A14 Baseband Generator



p2\_a18

W64/A14J13

A14

W65/A14J800



## A17 Baseband Generator Interface (E8267C Models Only)

### Tools Required

- 5.0 mm hex-nut driver
- 9/16" hex-nut driver
- needle-nose pliers

### Removal Procedure

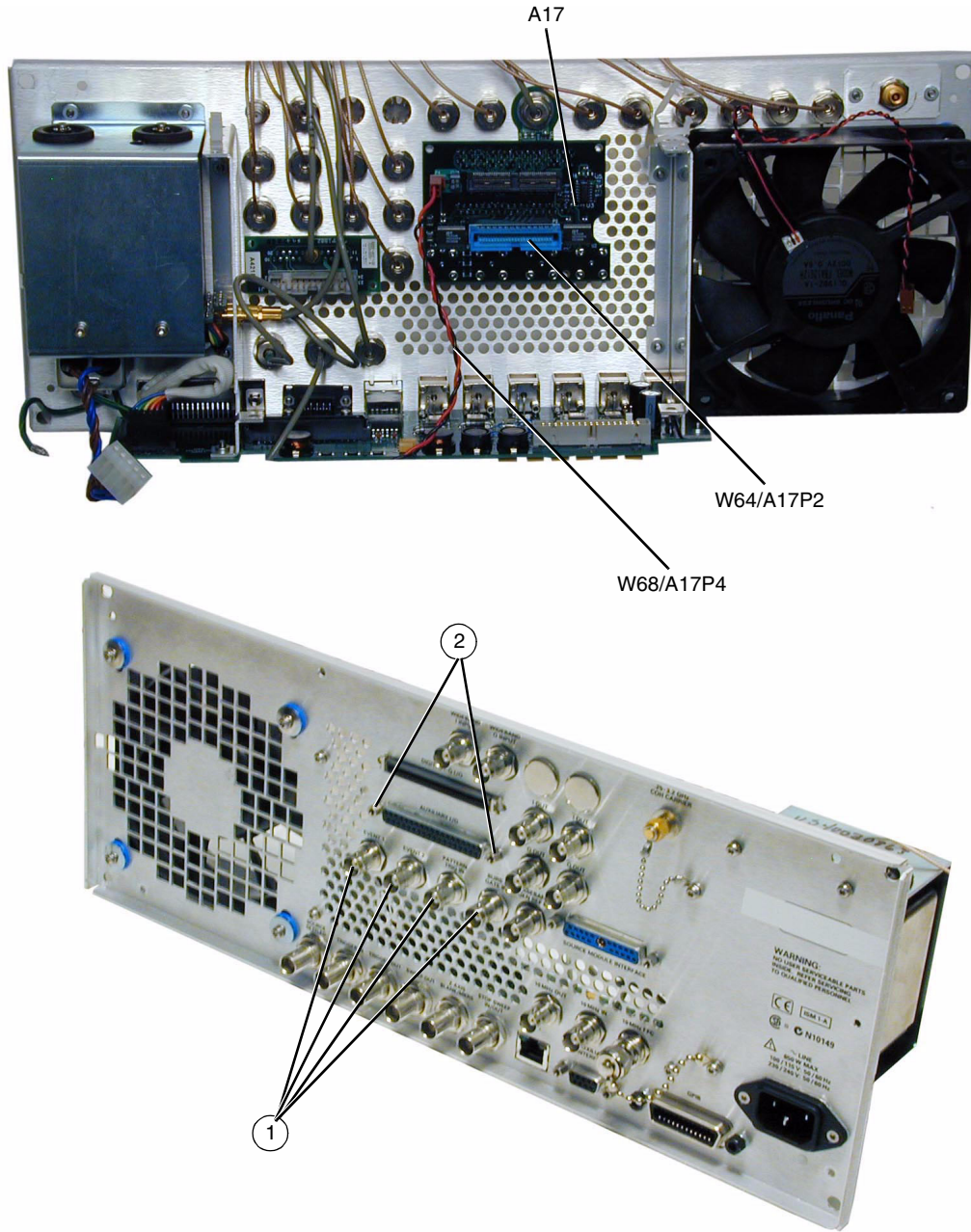
Refer to [Figure 2-16](#) for this procedure.

1. Disconnect the power cord.
2. Remove the covers from the signal generator. Refer to "[Outer Instrument Cover](#)" on page 2-5 and "[Inner Instrument Cover](#)" on page 2-7.
3. Remove the rear panel. Refer to "[Rear Panel \(Standard\)](#)" on page 2-44 or "[Rear Panel \(Option 1EM\)](#)" on page 2-47.
4. Disconnect the W64 ribbon cable from A17P2.
5. Using the needle-nose pliers, disconnect the W68 wire cable from A17P4.
6. Using the 9/16" hex-nut driver, remove the nuts and washers securing the four BNC connectors (1) on the rear panel.
7. Using the 5.0 mm driver, remove the hex screws (2) and washers that secure the A17 Baseband Generator Interface to the rear panel.
8. Remove the A17 Baseband Generator Interface.

### Replacement Procedure

- Reverse the order of the removal procedure.
- Torque all hex screws to 9 in-lbs.
- Perform the post-repair adjustments and performance tests that pertain to this removal procedure.

Figure 2-16 A17 Rear Panel Interface Board



p2\_a17

## A18 CPU

### Tools Required

- T-10 driver

### Removal Procedure

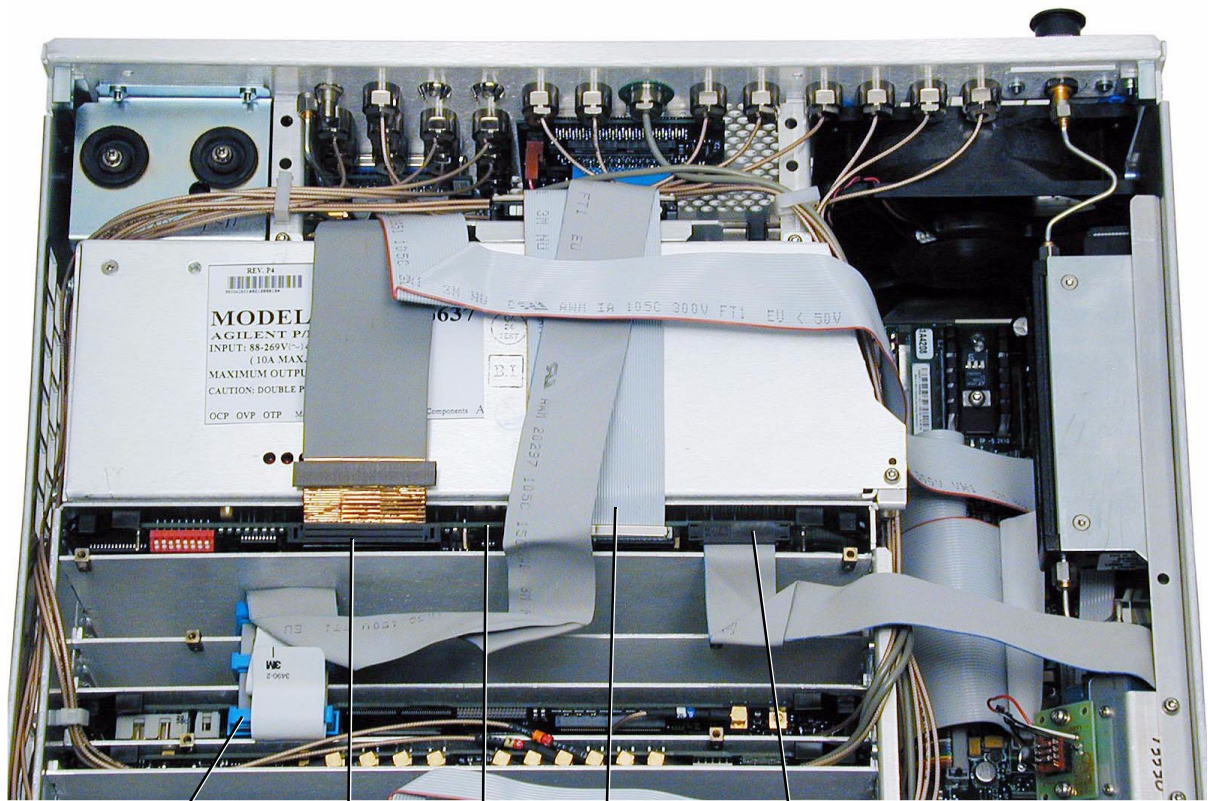
Refer to [Figure 2-17](#) for this procedure.

1. Disconnect the power cord.
2. Remove the covers from the signal generator. Refer to "[Outer Instrument Cover](#)" on page 2-5 and "[Inner Instrument Cover](#)" on page 2-7.
3. Position the signal generator with the front panel facing you.
4. Using the T-10 driver, remove the four screws from the Baseband Generator cover (E8267C Only).
5. Disconnect the following ribbon cables:
  - W19 from A18J2
  - W66 from A18P2
  - W18 from A18J1
  - W64 from A14J13
6. Lift the retention levers and disconnect the A18 CPU from the A31 Motherboard.
7. Lift the A18 CPU out of the slot.

### Replacement Procedure

- Reverse the order of the removal procedure.
- Perform the post-repair adjustments and performance tests that pertain to this removal procedure.

Figure 2-17 A18 CPU



W64/A14J13

W18/A18J1

A18

W66/A18P2

W19/A18J2

p2\_a18



## A18BT1

---

**WARNING** This battery contains lithium. Do not incinerate or puncture this battery. Do not install this battery backwards. To dispose of the battery in a safe manner, refer to [Chapter , "Lithium Battery Disposal," on page 5-3.](#)

---

### Tools Required

- flat head screw driver

### Removal Procedure

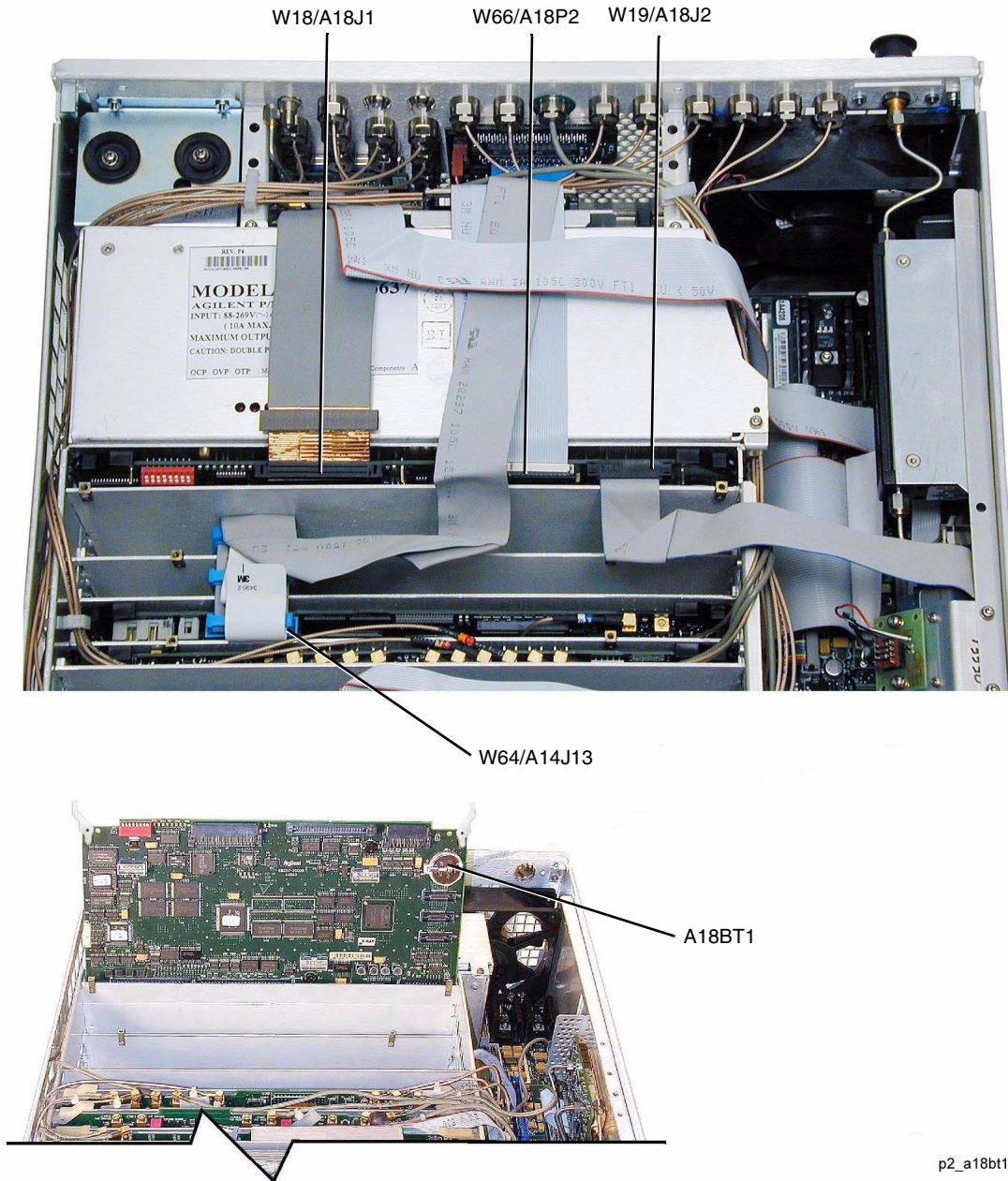
Refer to [Figure 2-17](#) for this procedure.

1. Disconnect the power cord.
2. Remove the covers from the signal generator. Refer to ["Outer Instrument Cover" on page 2-5](#) and ["Inner Instrument Cover" on page 2-7.](#)
3. Position the signal generator with the front panel facing you.
4. Using the T-10 driver, remove the four screws from the Baseband Generator cover.
5. Disconnect the following ribbon cables:
  - W19 from A18J2
  - W66 from A18P2
  - W18 from A18J1
  - W64 from A14J13
6. Lift the retention levers and disconnect the A18 CPU from the A31 Motherboard.
7. Lift the A18 CPU out of the slot.
8. Using the flat head screw driver, remove the A18BT1 by leveraging the battery out of the battery's socket.

### Replacement Procedure

- To install the battery, the positive side is aligned with the positive sign on the A18's battery clip.
- Reverse the remaining steps of the removal procedure.
- Perform the post-repair adjustments and performance tests that pertain to this removal procedure.

Figure 2-18 A18BT1



p2\_a18bt1

## A19 Power Supply

### Tools Required

- T-10 driver
- needle-nose pliers

### Removal Procedure

Refer to [Figure 2-19](#) for this procedure.

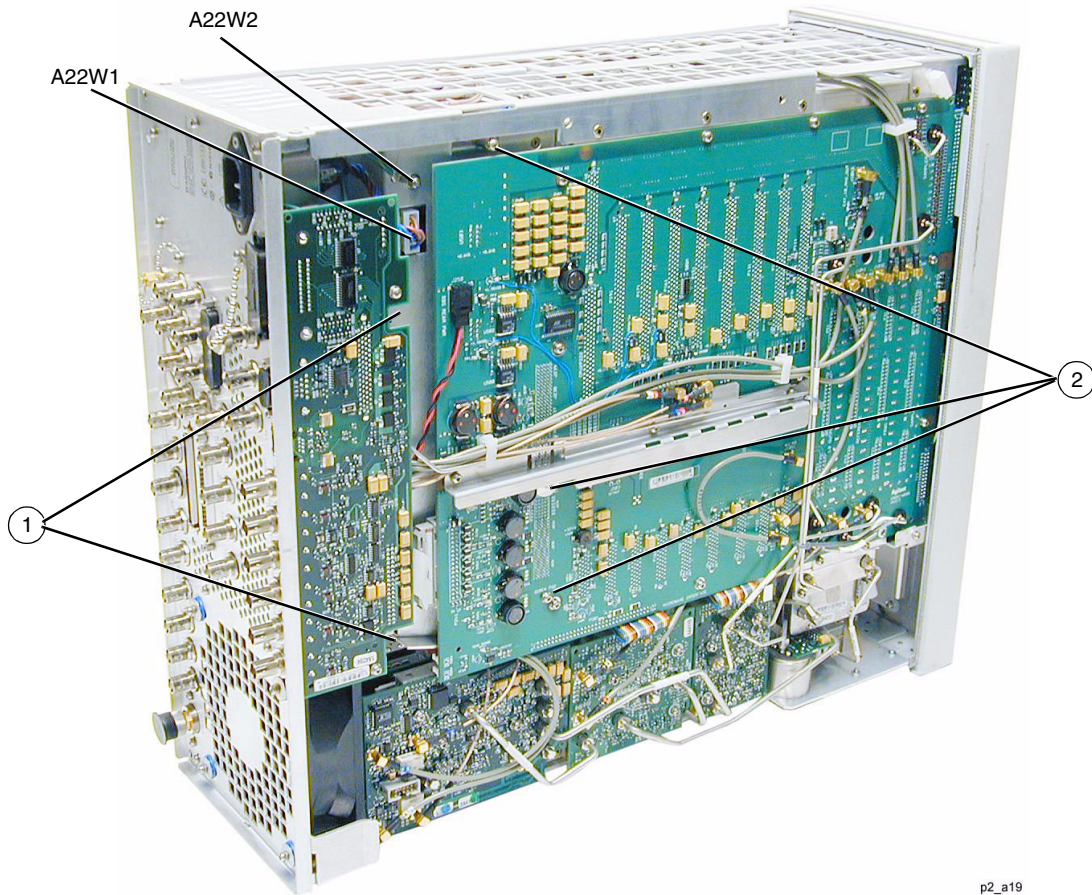
1. Disconnect the power cord.
2. Remove the covers from the signal generator. Refer to "[Outer Instrument Cover](#)" on page 2-5 and "[Inner Instrument Cover](#)" on page 2-7.
3. Position the signal generator with the A31 Motherboard facing you.
4. Disconnect the W20 ribbon cable from the A20 SMI.
5. Using the T-10 driver, remove the two screws (1) that secure the A19 Power Supply to the struts located on the bottom.
6. Using the T-10 driver, remove the three additional screws (2) that are attached to the bottom frame.
7. Using the needle-nose pliers, disconnect A22W1 from the power supply.
8. Using the T-10 driver, remove the screw securing the A22W2 to the A19 Power Supply.
9. Position the signal generator with the A31 Motherboard flat on the work surface and the rear panel facing you.
10. Disconnect the following ribbon cables:
  - W64 from A14 Baseband Generator A14J13 (E8267C only)
  - W66 from A18 CPU P2
  - W18 from A18 CPU J1
11. Using the T-10 driver, remove the two screws (3) that secure the A19 Power Supply to the struts located on the top and an additional screw (4) located on the top frame.
12. Move W20 to the side and remove the A19 Power Supply from the signal generator's chassis.
13. Remove the screw that attaches the A34 Internal Hard Drive to the A19 Power Supply (E8267C only).

### Replacement Procedure

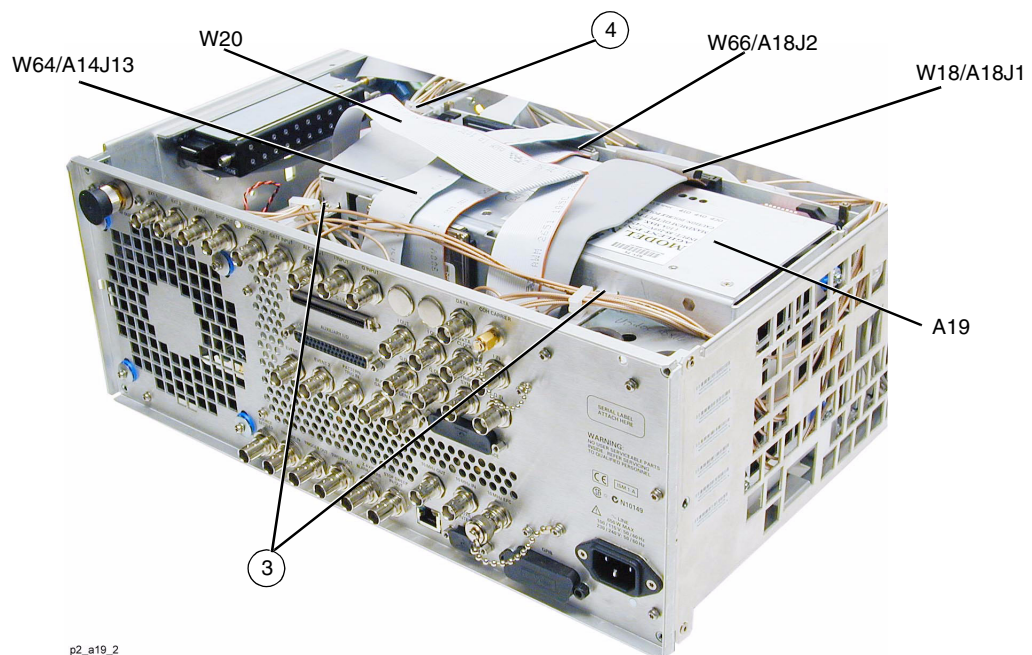
- Reverse the order of the removal procedure.
- Torque all T-10 screws to 9 in-lbs.
- Perform the post-repair adjustments and performance tests that pertain to this removal procedure.



**Figure 2-19**      **A19 Power Supply Removal**



p2\_a19



p2\_a19\_2

## Rear Panel (Standard)

### Tools Required

- T-10 driver
- needle-nose pliers

### Removal Procedure

Refer to [Figure 2-21](#) for this procedure.

1. Disconnect the power cord.
2. Remove the covers from the signal generator. Refer to "[Outer Instrument Cover](#)" on page 2-5 and "[Inner Instrument Cover](#)" on page 2-7.
3. Using the T-10 driver, remove the four screws from the Baseband Generator cover (E8267C only).
4. Position the signal generator with the A31 Motherboard panel facing you.
5. Using the needle-nose pliers, disconnect the following flexible cables:
  - W21(10 MHz output) from A31 Motherboard J1043
  - W47 from A31 Motherboard J1041
  - W22 (10 MHz input) from A31 Motherboard J1042
  - W68 (BBG Rear Pwr) from A31 Motherboard J250 (E8267C only)
  - W80 (WIDEBAND I INPUT) from A13 I/Q MUX J3 (E8267C only)
  - W79 (WIDEBAND Q INPUT) from A13 I/Q MUX J4 (E8267C only)
6. Position the signal generator with the rear panel facing you.
7. Using the needle-nose pliers, disconnect the following flexible cables:
  - W55 (SOURCE MOD INTERFACE) from A10 ALC J303
  - W65 (BASEBAND GEN REF IN) from A14 Baseband Generator Board J800 (E8267C only)
  - W56 (-Q OUT) from A35 3-20 GHz I/Q Modulator J14 (E8267C only)
  - W57 (-I OUT) from A35 3-20 GHz I/Q Modulator J13 (E8267C only)
  - W58 (Q OUT) from A35 3-20 GHz I/Q Modulator J12 (E8267C only)
  - W59 (I OUT) from A35 3-20 GHz I/Q Modulator J11 (E8267C only)
8. Using the 5/16" open ended wrench, disconnect the W67 RF cable (.25-3.2 GHz COH CARRIER) from the Rear Panel.
9. Disconnect the following ribbon cables:
  - W64 from A17 Baseband Generator Interface Board (E8267C only)
  - W20 from A20 SMI
  - W18 from A21 Rear-Panel Interface J3
  - W23 from A21 Rear-Panel Interface J2

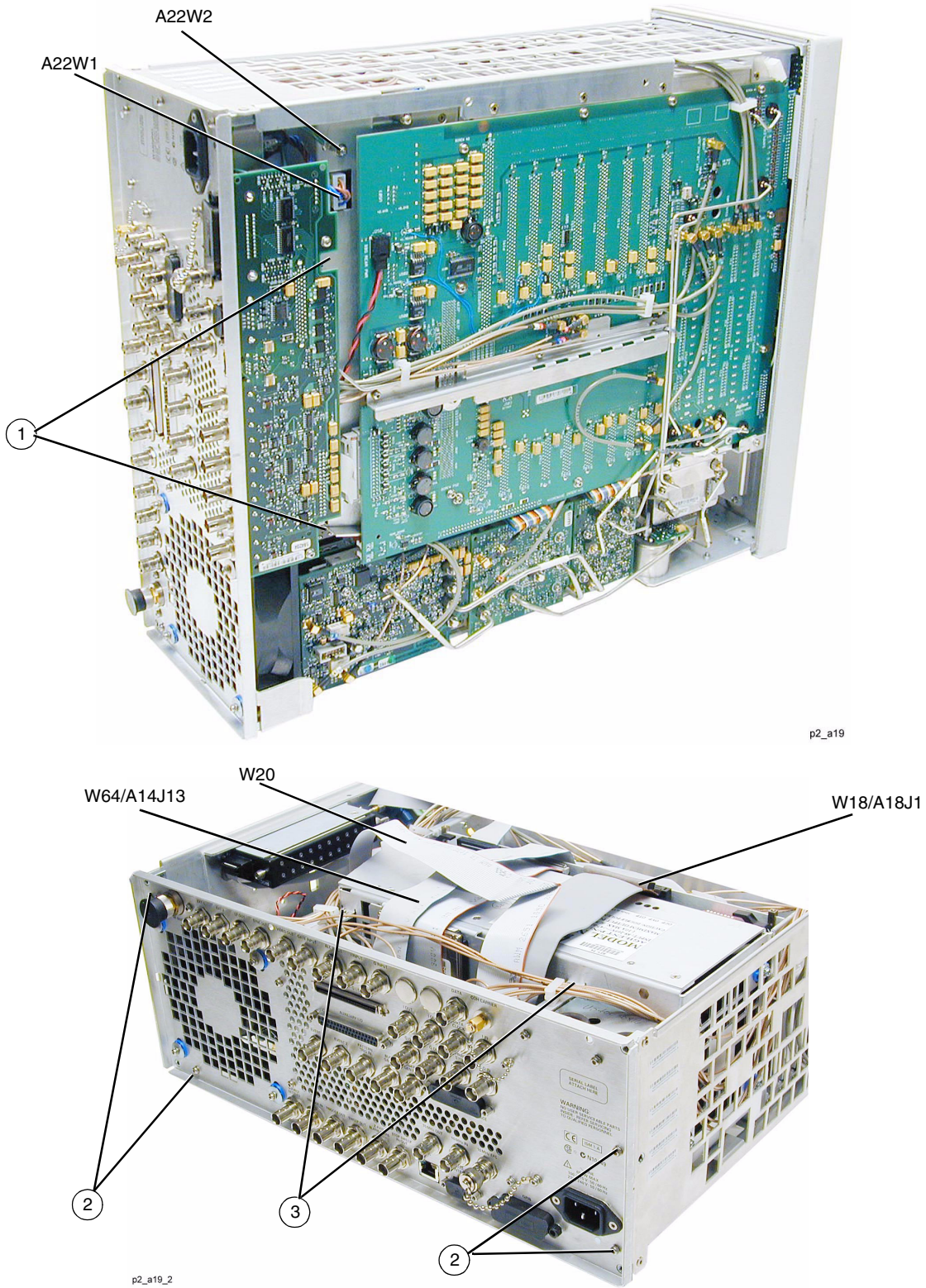
10. If the signal generator has option UNR, disconnect the W48 flexible cable from A32 10 MHz Crystal Oscillator (Option UNR).
11. Using the T-10 driver, remove the two screws (1) that secure the Rear Panel to the left and right struts.
12. Using the T-10 driver, remove the four screws (2) that attach the rear panel to the frame.
13. Using the T-10 driver, remove the two screws (3) that secure the Rear Panel to the left and right struts.
14. Using the needle-nose pliers, disconnect A22W1 from the power supply.
15. Using the T-10 driver, remove the screw securing the A22W2 to the A19 Power Supply.
16. Disconnect the B1 Fan cable from the A31 Motherboard P251.
17. Pull the rear panel away from the signal generator's chassis.

### **Replacement Procedure**

- Reverse the order of the removal procedure.
- Torque all T-10 screws to 9 in-lbs.
- Torque all RF connectors to 8 in-lbs.
- Perform the post-repair adjustments and performance tests that pertain to this removal procedure.



**Figure 2-20**      **Rear Panel Removal**



---

## Rear Panel (Option 1EM)

### Tools Required

- T-10 driver
- needle-nose pliers

### Removal Procedure

Refer to [Figure 2-21](#) for this procedure.

1. Disconnect the power cord.
2. Remove the covers from the signal generator. Refer to "[Outer Instrument Cover](#)" on page 2-5 and "[Inner Instrument Cover](#)" on page 2-7.
3. Using the T-10 driver, remove the four screws from the Baseband Generator cover (E8267C only).
4. Position the signal generator with the A31 Motherboard panel facing you.
5. Using the needle-nose pliers, disconnect the following flexible cables:
  - W21 (10 MHz output) from A31 Motherboard J1043
  - W47 from A31 Motherboard J1041
  - W22 (10 MHz input) from A31 Motherboard J1042
  - W51 (Data) from A31 Motherboard J500 (E8267C only)
  - W52 (Data Clock) from A31 Motherboard J501 (E8267C only)
  - W53 (SYMBOL SYNC) from A31 Motherboard J502 (E8267C only)
  - W68 (BBG Rear Pwr) from A31 Motherboard J250 (E8267C only)
  - W80 (WIDEBAND I INPUT) from A13 I/Q MUX J3 (E8267C only)
  - W79 (WIDEBAND Q INPUT) from A13 I/Q MUX J4 (E8267C only)
6. Using the needle-nose pliers, disconnect A22W1 from the power supply.
7. Position the signal generator with the rear panel facing you.
8. Using the needle-nose pliers, disconnect the following flexible cables:
  - W55 (SOURCE MOD INTERFACE) from A10 ALC J303.
  - W4 (ALC INPUT) from the A10 ALC J4
  - W6 (PULSE VIDEO OUTPUT) from A11 Pulse/Analog Modulation Generator J203
  - W7 (PULSE SYNC OUTPUT) from A11 Pulse/Analog Modulation Generator J202
  - W5 (PULSE/TRIGGER GATE INPUT) from A11 Pulse/Analog Modulation Generator J201
  - W3 (LF OUTPUT) from A11 Pulse/Analog Modulation Generator J403
  - W2 (EXT 2 INPUT) from A11 Pulse/Analog Modulation Generator J402
  - W1 (EXT 1 INPUT) from A11 Pulse/Analog Modulation Generator J401

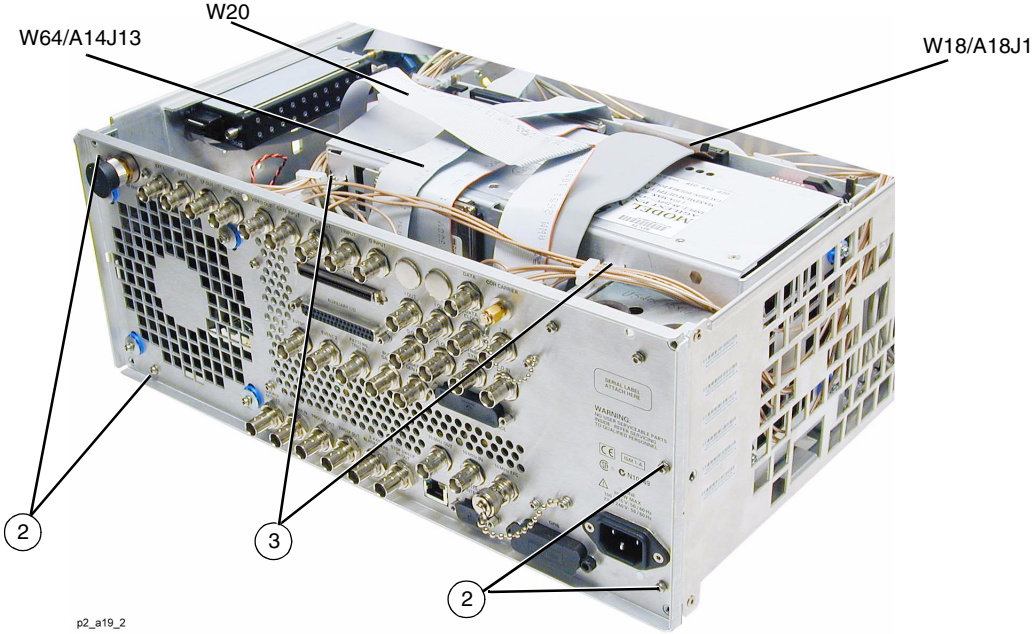
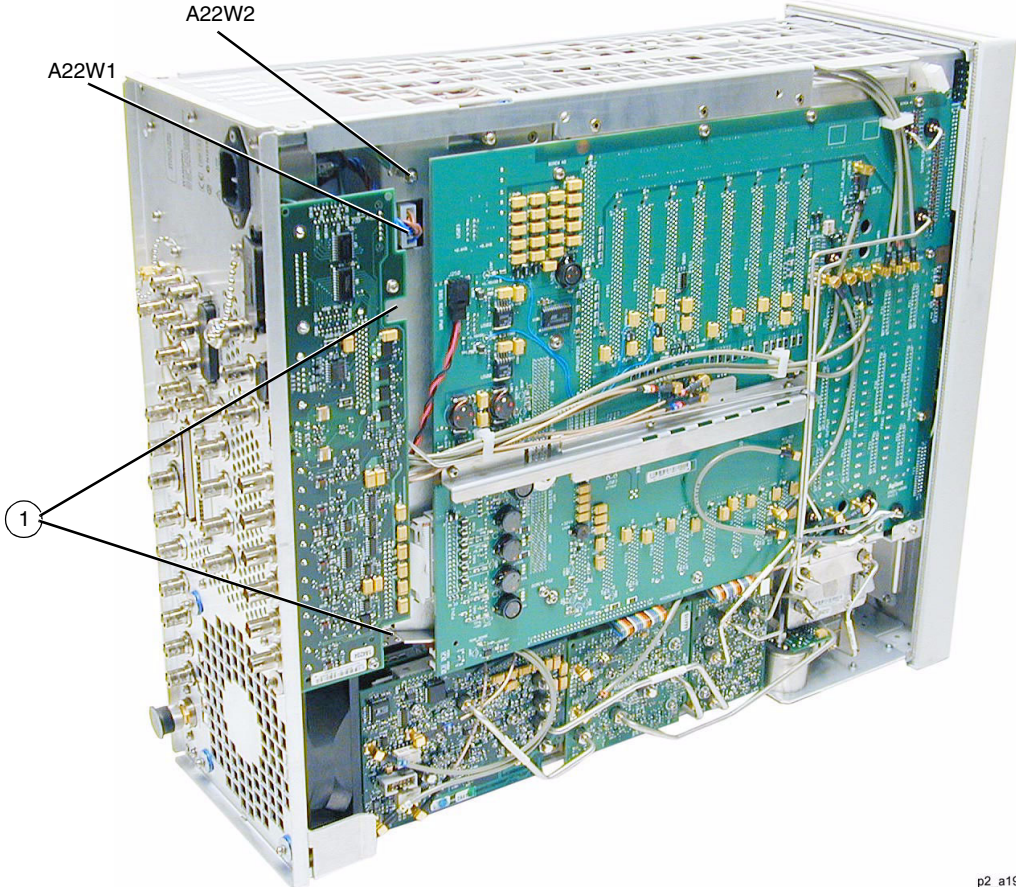


- W56 (-Q OUT) from A35 3-20 GHz I/Q Modulator J14 (E8267C only)
  - W57 (-I OUT) from A35 3-20 GHz I/Q Modulator J13 (E8267C only)
  - W58 (Q OUT) from A35 3-20 GHz I/Q Modulator J12 (E8267C only)
  - W59 (I OUT) from A35 3-20 GHz I/Q Modulator J11 (E8267C only)
  - W50 (Q IN) from A35 3-20 GHz I/Q Modulator J8 (E8267C only)
  - W49 (I IN) from A35 3-20 GHz I/Q Modulator J7 (E8267C only)
  - W65 (BASEBAND GEN REF IN) from A14 Baseband Generator Board J800 (E8267C only)
9. Using the 5/16" open ended wrench, disconnect the following RF cables
- W67 (.25-3.2 GHz COH CARRIER) from Rear Panel
  - W73 from AT1 115 dB High-Power Mechanical Attenuator
10. Disconnect the following ribbon cables:
- W64 from A17 Baseband Generator Interface Board P2 (E8267C only)
  - W20 from A20 SMI J1
  - W18 from A21 Rear-Panel Interface J3
  - W23 from A21 Rear-Panel Interface J2
11. If the signal generator has option UNR, disconnect the W48 flexible cable from A32 10 MHz Crystal Oscillator (Option UNR).
12. Using the T-10 driver, remove the two screws (1) that secure the Rear Panel to the left and right struts.
13. Using the T-10 driver, remove the four screws (2) that attach the rear panel to the frame.
14. Using the T-10 driver, remove the two screws (3) that secure the Rear Panel to the left and right struts.
15. Using the T-10 driver, remove the screw securing the A22W2 to the A19 Power Supply.
16. Disconnect the B1 Fan cable from the A31 Motherboard P251.
17. Pull the rear panel away from the signal generator's chassis.

## Replacement Procedure

- Reverse the order of the removal procedure.
- Torque all T-10 screws to 9 in-lbs.
- Torque all RF connectors to 8 in-lbs.
- Perform the post-repair adjustments and performance tests that pertain to this removal procedure.

**Figure 2-21 Rear Panel Removal (Option 1EM)**



## A20 SMI (Source Module Interface)

### Tools Required

- 5.0 mm hex-nut driver
- needle-nose pliers

### Removal Procedure

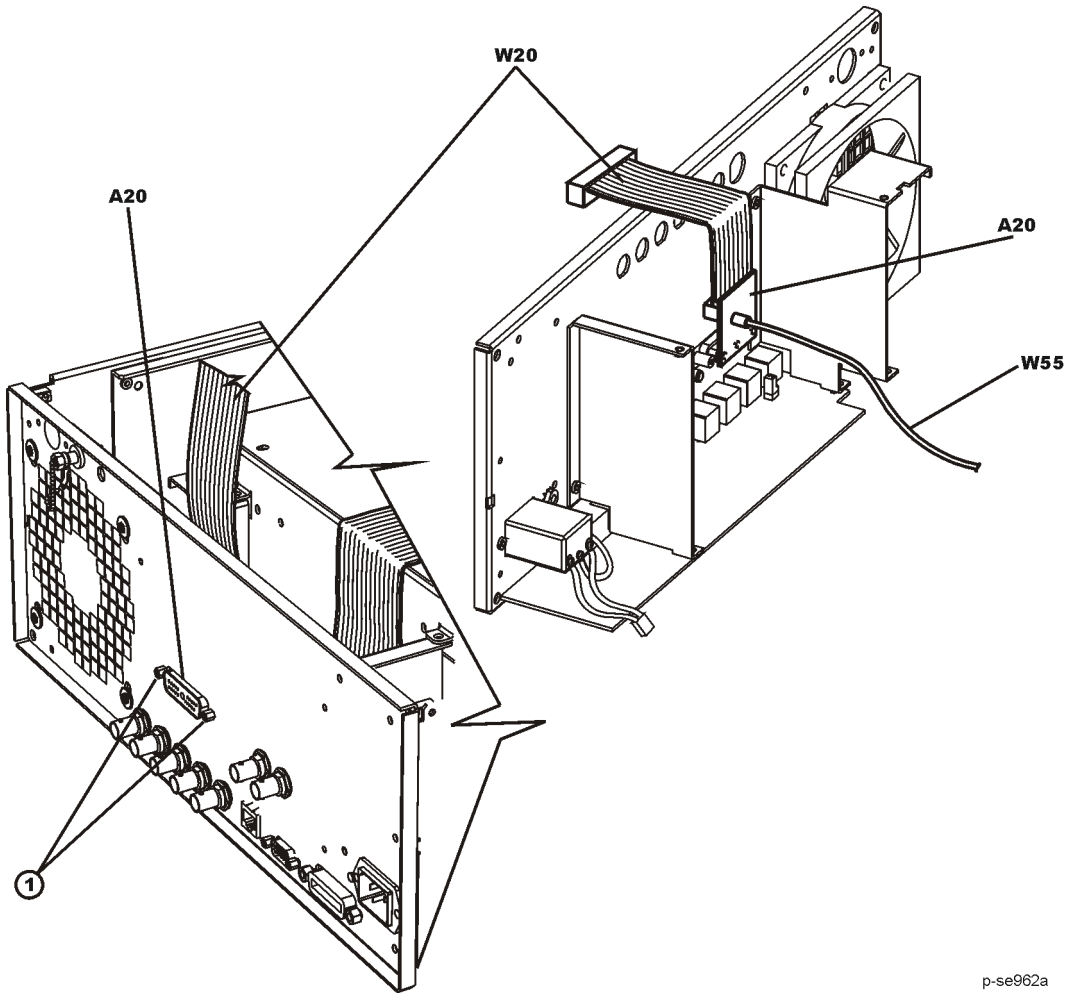
Refer to [Figure 2-22](#) for this procedure.

1. Disconnect the power cord.
2. Remove the covers from the signal generator. Refer to "[Outer Instrument Cover](#)" on page 2-5 and "[Inner Instrument Cover](#)" on page 2-7.
3. Using the needle-nose pliers, disconnect the W55 flexible cable from the A10 ALC J303.
4. Disconnect the W20 ribbon cable from the A26 MID J20.
5. Using the 5.0 mm driver, remove the hex screws (1) and washers that secure the A20 SMI to the rear panel.
6. Remove the A20 SMI.

### Replacement Procedure

- Reverse the order of the removal procedure.
- Torque all hex screws to 9 in-lbs.
- Perform the post-repair adjustments and performance tests that pertain to this removal procedure.

Figure 2-22 A20 SMI



p-se962a

## A21 Rear-Panel Interface

### Tools Required

- T-10 driver
- 9/16" hex-nut driver
- 5.0 mm hex-nut driver
- 7.0 mm hex-nut driver
- needle-nose pliers

### Removal Procedure

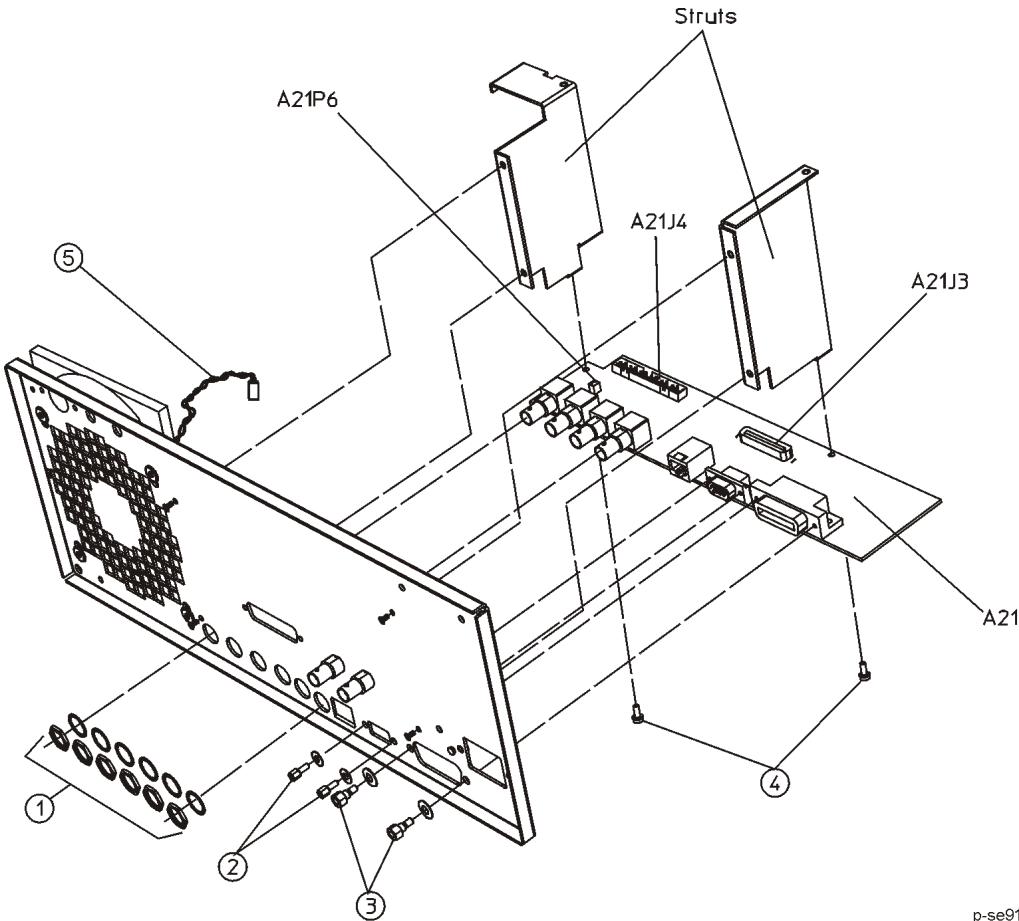
Refer to [Figure 2-23](#) for this procedure.

1. Disconnect the power cord.
2. Remove the covers from the signal generator. Refer to "[Outer Instrument Cover](#)" on page 2-5 and "[Inner Instrument Cover](#)" on page 2-7.
3. Remove the rear panel. Refer to "[Rear Panel \(Standard\)](#)" on page 2-44 or "[Rear Panel \(Option 1EM\)](#)" on page 2-47.
4. Using the 9/16" hex-nut driver, remove the nuts and washers securing the six BNC connectors (1) at the base of the rear panel.
5. Using the 5.0 mm hex-nut driver, remove the screws (2) from the RS-232 port.
6. Using the 7.0 mm hex-nut driver, remove the screws (3) from the GPIB port.
7. Using the T-10 driver, remove the two screws (4) from the bottom of the A21 Rear-Panel Interface.
8. Disconnect the B1 Fan cable (5) from A31P251.
9. If you have Option UNR, disconnect the A32 10 MHz Crystal Oscillator (Option UNR) cable from A21P2.
10. Remove the A21 Rear-Panel Interface.

### Replacement Procedure

- Reverse the order of the removal procedure.
- Torque all T-10 screws to 9 in-lbs.
- Torque all hex-nuts to 9 in-lbs.
- Torque all BNC nuts to 21 in-lbs.
- Perform the post-repair adjustments and performance tests that pertain to this removal procedure.

Figure 2-23 A21 Rear-Panel Interface



p-se913a

## A22 Line Module

### Tools Required

- T-10 driver
- 5.0 mm wrench
- needle-nose pliers

### Removal Procedure

Refer to [Figure 2-24](#) for this procedure.

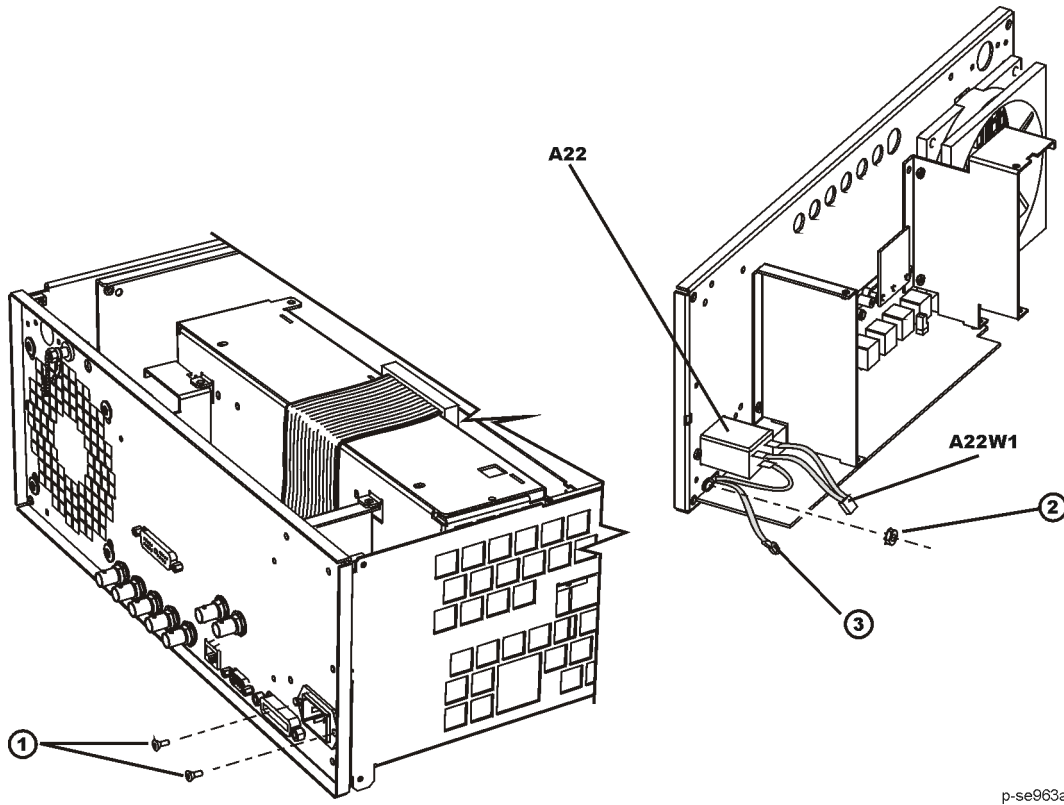
1. Disconnect the power cord.
2. Remove the covers from the signal generator. Refer to "[Outer Instrument Cover](#)" on page 2-5 and "[Inner Instrument Cover](#)" on page 2-7.
3. Position the signal generator with the rear panel facing you.
4. If the signal generator has Option UNR, refer to "[A32 10 MHz Crystal Oscillator \(Option UNR\)](#)" on page 2-90 to remove the assembly.
5. Using the T-10 driver, remove the two screws (1) that attach the A22 Line Module to the rear panel.
6. Using the 5.0 mm wrench, remove the nut (2) and washer from the grounding screw connecting A22W2 to the rear panel.
7. Using the T-10 driver, remove the screw (3) that attaches the A22W2 to the bottom of the A19 Power Supply (E8267C only).
8. Using the needle-nose pliers, disconnect the A22W1 from the bottom of the A19 Power Supply.
9. Remove the A22 Line Module

### Replacement Procedure

- Reverse the order of the removal procedure.
- Torque all T-10 screws to 9 in-lbs.
- Torque all nuts to 9 in-lbs.
- Perform the post-repair adjustments and performance tests that pertain to this removal procedure.



Figure 2-24 A22 Line Module Removal





## AT1 115 dB Attenuator

### Tools Required

- T-10 driver
- 5/16" open ended wrench

### Removal Procedure

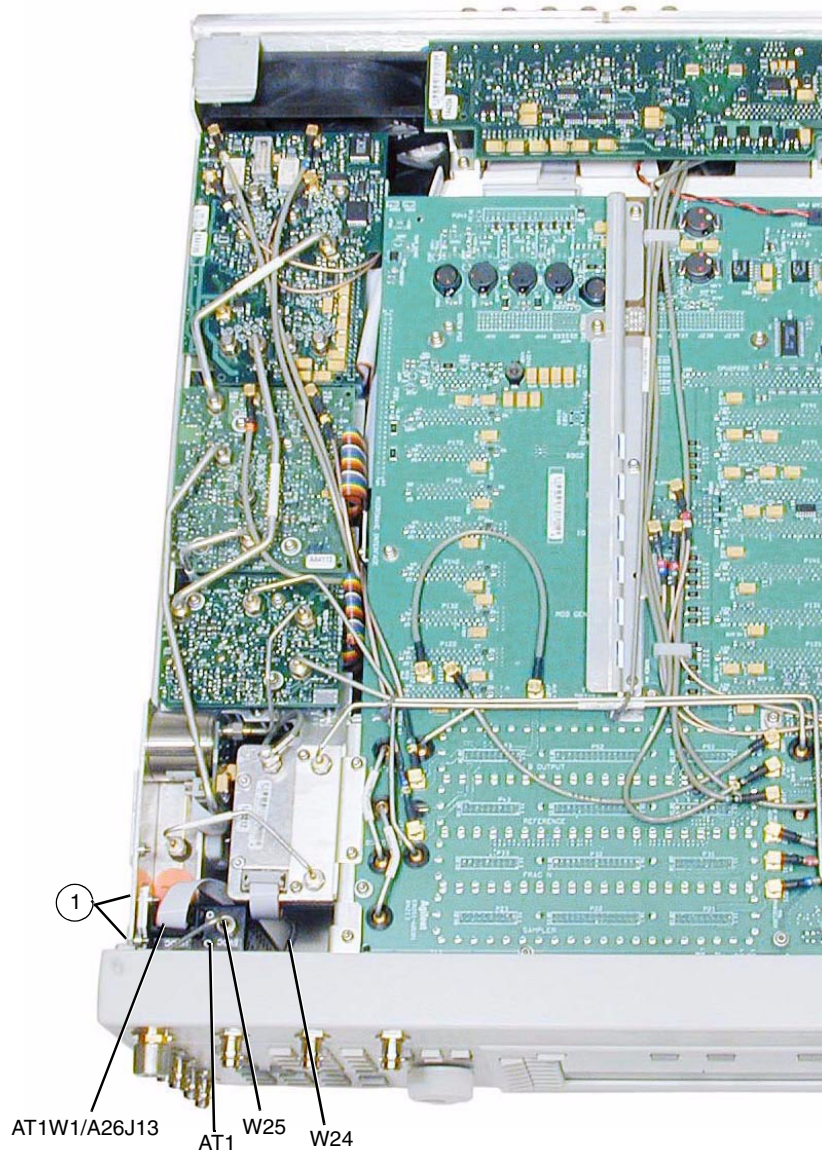
Refer to [Figure 2-25](#) for this procedure.

1. Disconnect the power cord.
2. Remove the covers from the signal generator. Refer to "[Outer Instrument Cover](#)" on page 2-5 and "[Inner Instrument Cover](#)" on page 2-7.
3. Position the signal generator with the A31 Motherboard facing you so that the RF deck is on top.
4. Disconnect the AT1W1 ribbon cable from A26J13.
5. Using the 5/16" open ended wrench, disconnect the W24 and W25 RF cables from the AT1 115 dB Attenuator.
6. Using the T-10 driver, remove the two screws (1) that attach the AT1 115 dB Attenuator to the side panel.
7. Remove the attenuator from the A26 MID bracket.
8. Using the T-10 driver, remove the sheet metal from the attenuator.

### Replacement Procedure

- Reverse the order of the removal procedure.
- Torque all T-10 screws to 9 in-lbs.
- Torque all RF connectors to 8 in-lbs.
- Perform the post-repair adjustments and performance tests that pertain to this removal procedure.

Figure 2-25 AT1 115 dB Attenuator (Option 1E1)



## AT1 115 dB Attenuator (Option 1EM)

### Tools Required

- T-10 driver
- 5/16" open ended wrench

### Removal Procedure

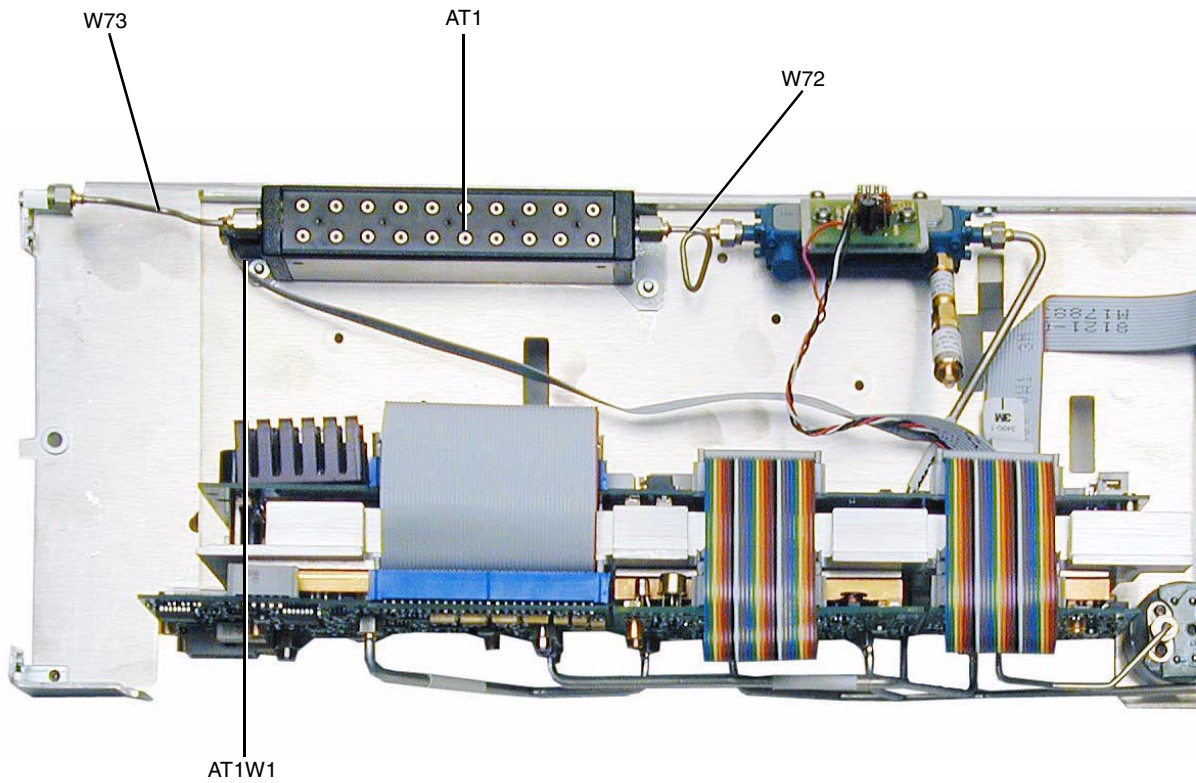
Refer to [Figure 2-25](#) for this procedure.

1. Disconnect the power cord.
2. Remove the covers from the signal generator. Refer to "[Outer Instrument Cover](#)" on page 2-5 and "[Inner Instrument Cover](#)" on page 2-7.
3. Position the signal generator with the A31 Motherboard facing you so that the RF deck is on top.
4. Disconnect the AT1W1 ribbon cable from A26J13.
5. Using the 5/16" open ended wrench, disconnect the W72 and W73 RF cables from the AT1 115 dB Attenuator.
6. Using the T-10 driver, remove the two screws that attach the AT1 115 dB Attenuator to the side panel.
7. Remove the AT1 115 dB Attenuator.
8. Using the T-10 driver, remove the sheet metal from the attenuator.

### Replacement Procedure

- Reverse the order of the removal procedure.
- Torque all T-10 screws to 9 in-lbs.
- Torque all RF connectors to 8 in-lbs.
- Perform the post-repair adjustments and performance tests that pertain to this removal procedure.

**Figure 2-26**      **AT1 115 dB Attenuator (Option 1E1)**



## A23 Low Band Coupler/Detector

### Tools Required

- T-10 driver
- 5/16" open ended wrench
- wire cutters

### Removal Procedure

Refer to [Figure 2-27](#) for this procedure.

1. Disconnect the power cord.
2. Remove the covers from the signal generator. Refer to "[Outer Instrument Cover](#)" on page 2-5 and "[Inner Instrument Cover](#)" on page 2-7.
3. Position the signal generator so that the A31 Motherboard is facing you and the RF deck is on top.
4. Using the 5/16" open ended wrench, disconnect the W27 RF cable from the A23 Low Band Coupler/Detector.
5. Using the wire cutters, cut the tie wrap that secures the W27 RF cable to the A23 Low Band Coupler/Detector.
6. Using the 5/16" open ended wrench, disconnect the following RF cable according to the signal generator you have.

**E8247C/57C:** Disconnect the W37 RF cable from the A23 Low Band Coupler/Detector.

**E8267C:** Disconnect the W75 RF cable from the A23 Low Band Coupler/Detector.

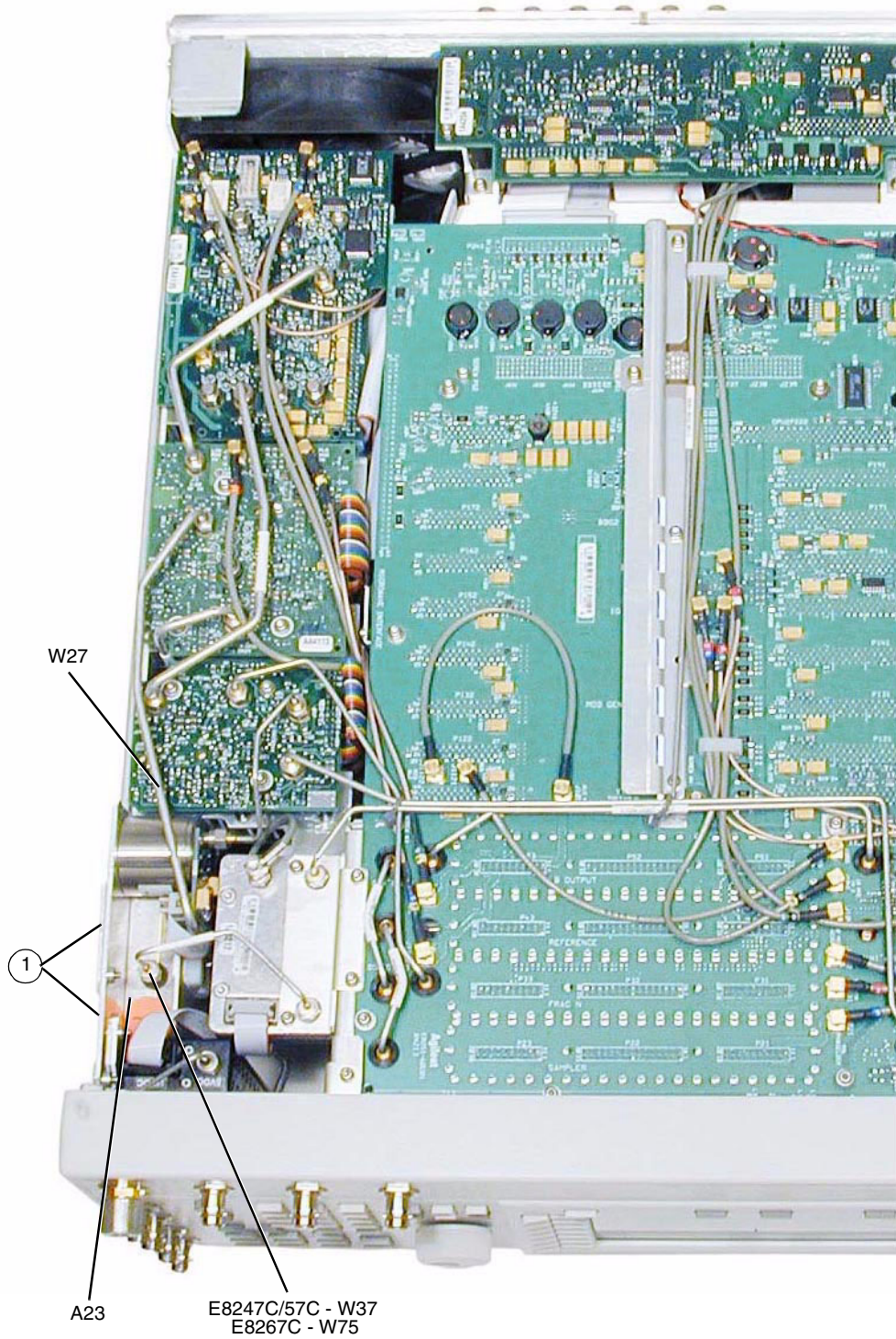
7. Using the T-10 driver, remove the two screws that attach the A23 Low Band Coupler/Detector to the side panel.
8. Disconnect the W28 ribbon cable from the A23 Low Band Coupler/Detector (not shown in [Figure 2-27](#)).
9. Disconnect the W14 flexible cable from the A23 Low Band Coupler/Detector (not shown in [Figure 2-27](#)).
10. Remove the A23 Low Band Coupler/Detector.

### Replacement Procedure

- Reverse the order of the removal procedure.
- Torque all T-10 screws to 9 in-lbs.
- Torque all RF connectors to 8 in-lbs.
- Perform the post-repair adjustments and performance tests that pertain to this removal procedure.



Figure 2-27 A23 Low Band Coupler/Detector



## A24 20 GHz Highband Coupler (Option 520 Only)

### Tools Required

- T-10 driver
- 5/16" open ended wrench

### Removal Procedure

Refer to [Figure 2-28](#) for this procedure.

1. Disconnect the power cord.
2. Remove the covers from the signal generator. Refer to "[Outer Instrument Cover](#)" on page 2-5 and "[Inner Instrument Cover](#)" on page 2-7.
3. Position the signal generator with the A31 Motherboard facing away from you and the RF deck on top.
4. Using the 5/16" open ended wrench, disconnect the following assembly according to the signal generator you have.

**E8247C/57C:** Disconnect the A25 High Band Detector from the A24 20 GHz High Band Coupler.

**E8267C:** Disconnect the A33 6dB PAD from the A24 20 GHz High Band Coupler.

5. Using the 5/16" open ended wrench, disconnect the following RF cables according to the signal generator you have.

**Standard:** Disconnect W74 and W24 RF cables from the A24 20 GHz High Band Coupler's input and output.

**Option 1EM:** Disconnect W71 and W72 RF cables from the A24 20 GHz High Band Coupler's input and output.

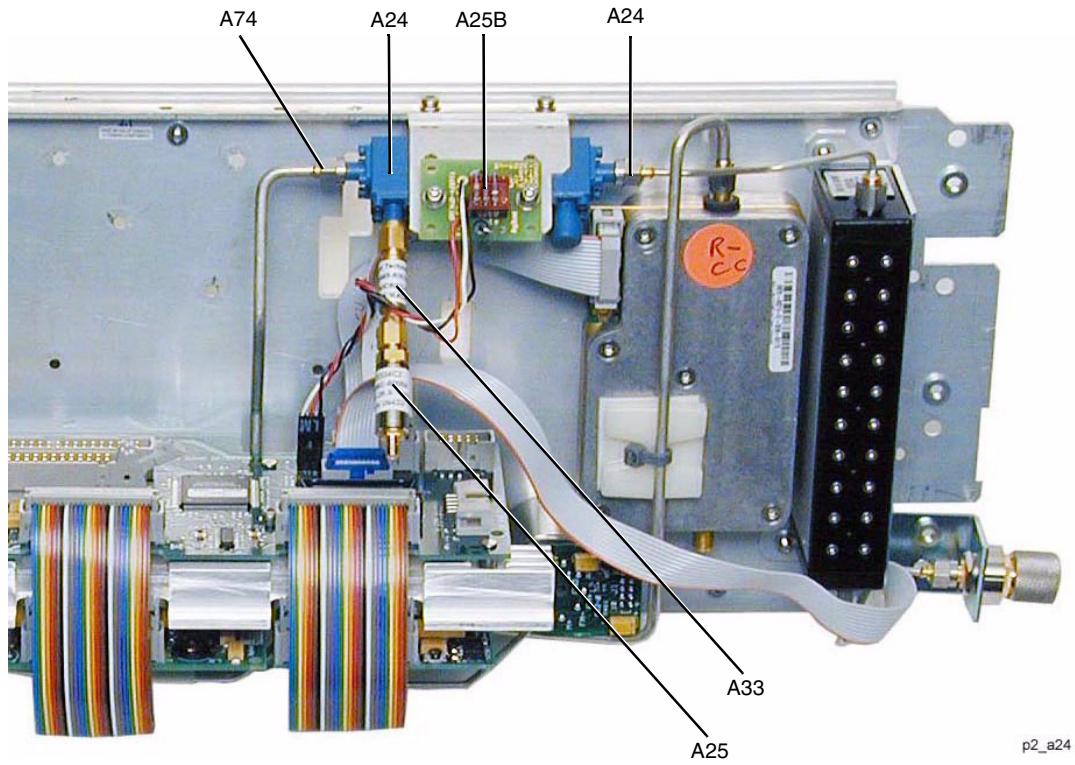
6. Using the T-10 driver, remove the two screws that connect the A25B Highband Detector Bias Board to the A24 20 GHz High Band Coupler.
7. Using the T-10 driver, remove the two screws that attach the coupler to the side panel.
8. Remove the A24 20 GHz High Band Coupler.

### Replacement Procedure

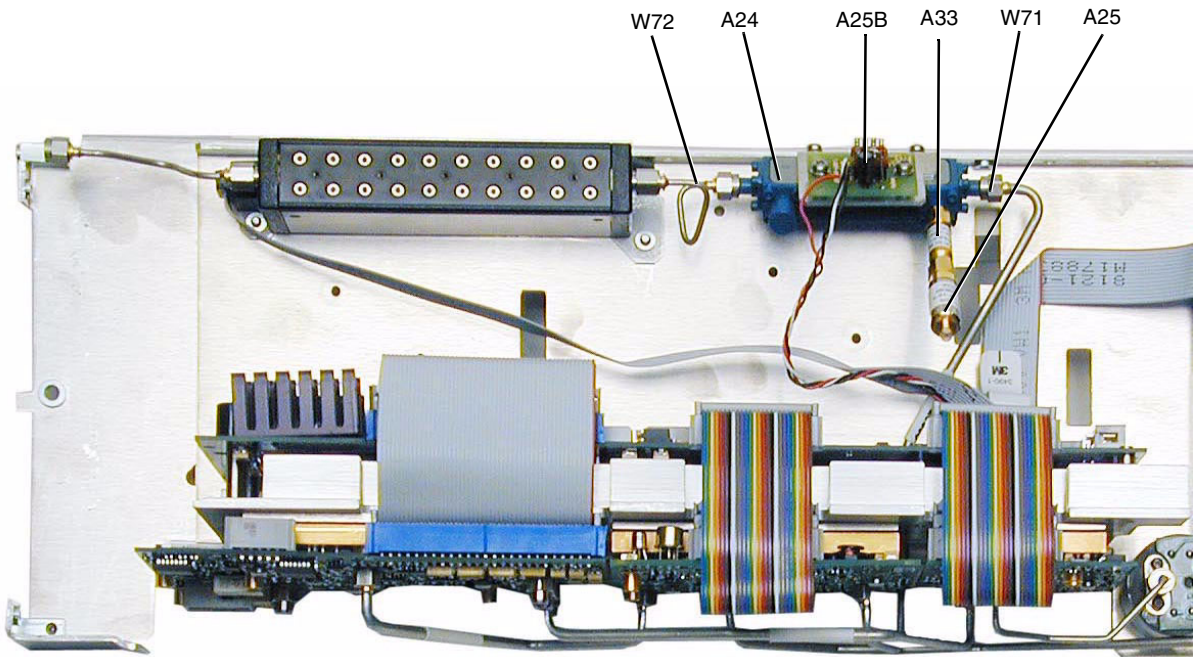
- Reverse the order of the removal procedure.
- Torque all T-10 screws to 9 in-lbs.
- Torque all RF connectors to 8 in-lbs.
- Perform the post-repair adjustments and performance tests that pertain to this removal procedure.



**Figure 2-28**      **A24 20 GHz High Band Coupler (Standard)**



**Figure 2-29**      **A24 20 GHz High Band Coupler (Option 1EM)**





## A24 40 GHz Highband Coupler (Option 540 Only)

### Tools Required

- T-10 driver
- 5/16" open ended wrench

### Removal Procedure

Refer to [Figure 2-28](#) for this procedure.

1. Disconnect the power cord.
2. Remove the covers from the signal generator. Refer to "[Outer Instrument Cover](#)" on page 2-5 and "[Inner Instrument Cover](#)" on page 2-7.
3. Position the signal generator with the A31 Motherboard facing away from you and the RF deck on top.
4. Using the 5/16" open ended wrench, disconnect the A25 High Band Detector from the A24 40 GHz High Band Coupler.
5. Using the 5/16" open ended wrench, disconnect the following cables according to the signal generator you have.

**Standard:** Disconnect W30 and W24 RF cables from the A24 40 GHz High Band Coupler's input and output.

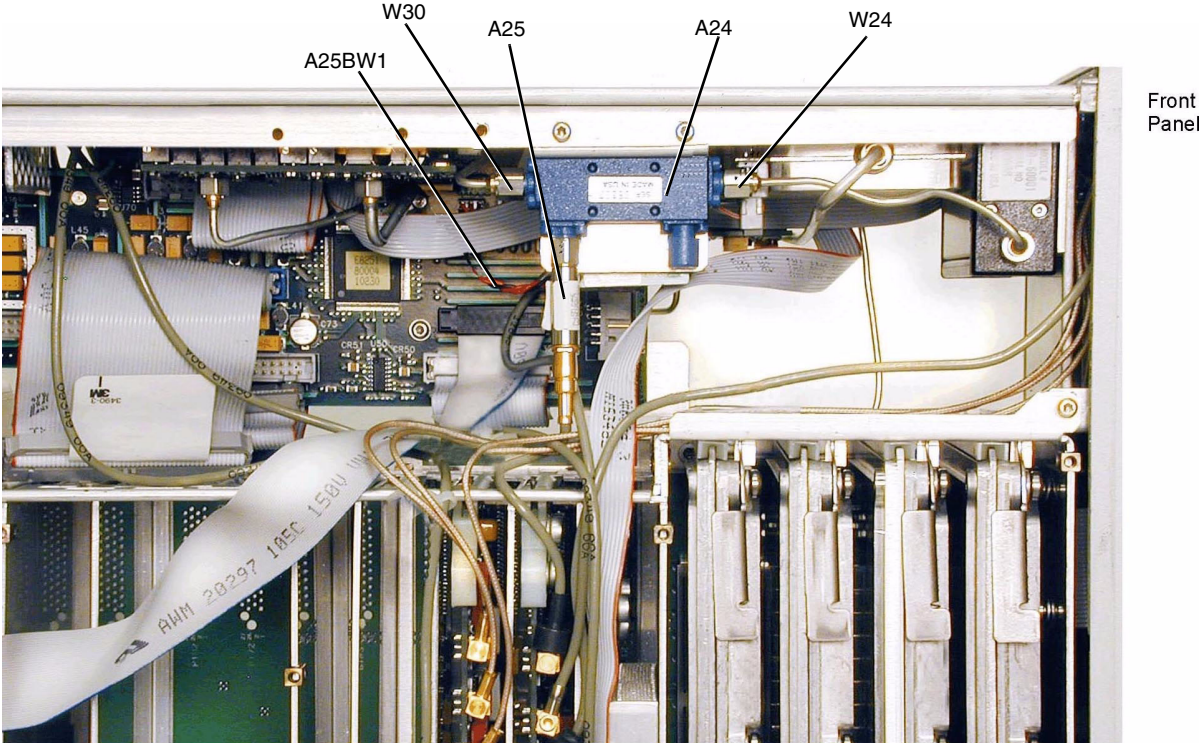
**Option 1EM:** Disconnect W71 and W72 RF cables from the A24 40 GHz High Band Coupler's input and output.

6. Using the T-10 driver, remove the two screws that connect the A25B Highband Detector Bias Board to the A24 40 GHz High Band Coupler.
7. Using the T-10 driver, remove the two screws that attach the coupler to the side panel.
8. Remove the A24 40 GHz High Band Coupler.

### Replacement Procedure

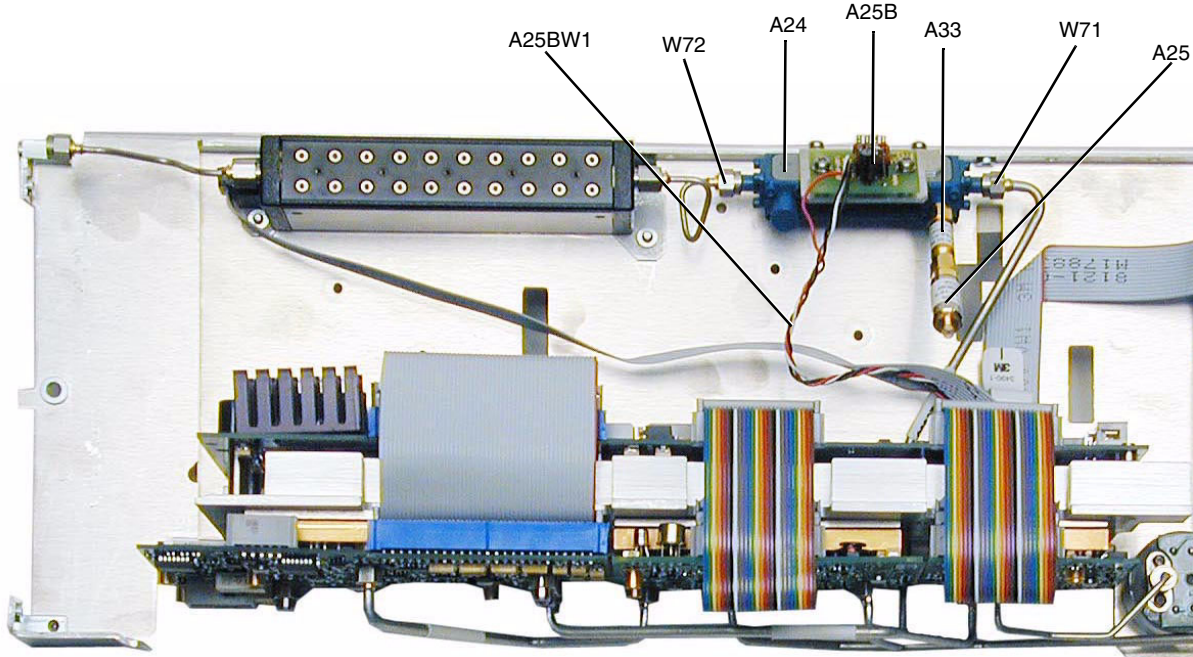
- Reverse the order of the removal procedure.
- Torque all T-10 screws to 9 in-lbs.
- Torque all RF connectors to 8 in-lbs.
- Perform the post-repair adjustments and performance tests that pertain to this removal procedure.

**Figure 2-30 A24 40 GHz High Band Coupler (Standard)**



p-se959a

**Figure 2-31 A24 20 GHz High Band Coupler (Option 1EM)**



## A25 20 GHz Highband Detector

### Tools Required

- 5/16" open ended wrench
- needle-nose pliers

### Removal Procedure

Refer to [Figure 2-32](#) for this procedure.

1. Disconnect the power cord.
2. Remove the covers from the signal generator. Refer to "[Outer Instrument Cover](#)" on page 2-5 and "[Inner Instrument Cover](#)" on page 2-7.
3. Position the signal generator with the A31 Motherboard facing away from you and the RF deck on top.
4. Using the 5/16" open ended wrench, disconnect the A25 20 GHz High Band Detector according to the signal generator you have.

**E8247C/57C:** Disconnect the A25 High Band Detector from the A24 20 GHz High Band Coupler.

**E8267C:** Disconnect the A25 20 GHz High Band Detector from the A33 6dB PAD.

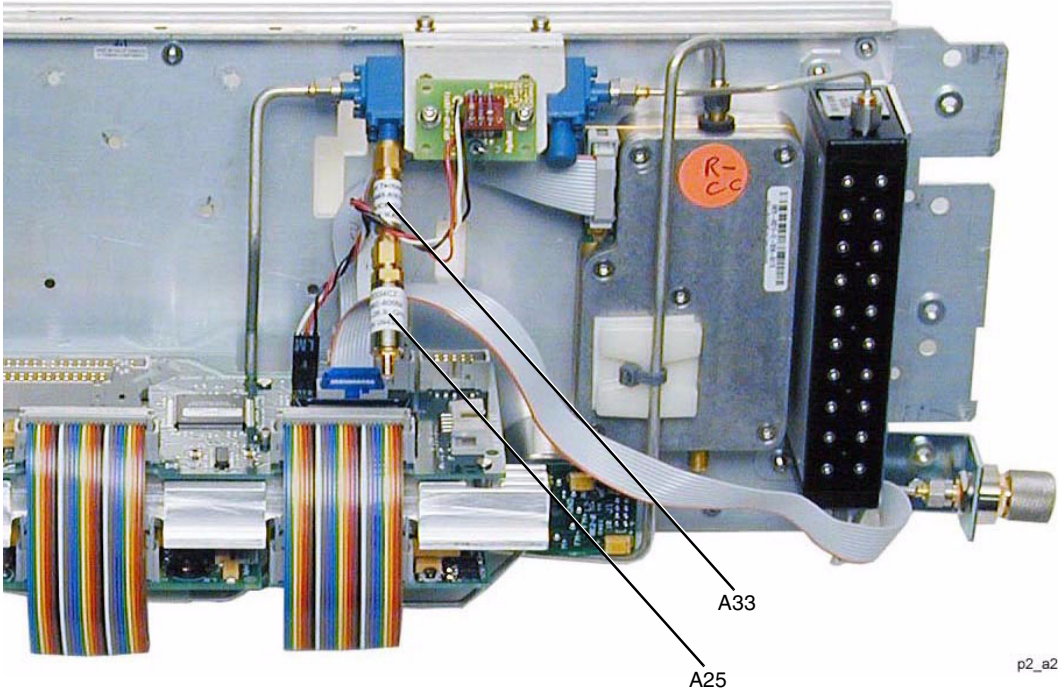
5. Using the needle-nose pliers, disconnect W82 from the A25 20 GHz High Band Detector.
6. Remove the A25 20 GHz High Band Detector.

### Replacement Procedure

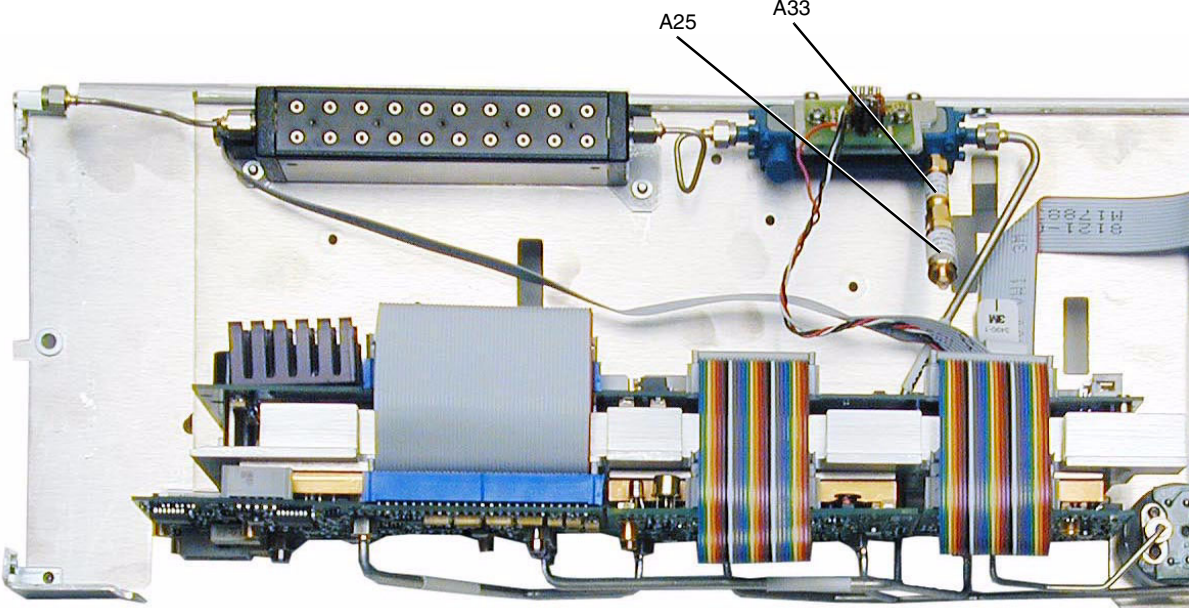
- Reverse the order of the removal procedure.
- Perform the post-repair adjustments and performance tests that pertain to this removal procedure.



**Figure 2-32** A25 20 GHz High Band Detector



**Figure 2-33** A25 20 GHz High Band Coupler (Option 1EM)



## A25 40 GHz Highband Detector (Option 540 Only)

### Tools Required

- T-10 driver
- 5/16" open ended wrench

### Removal Procedure

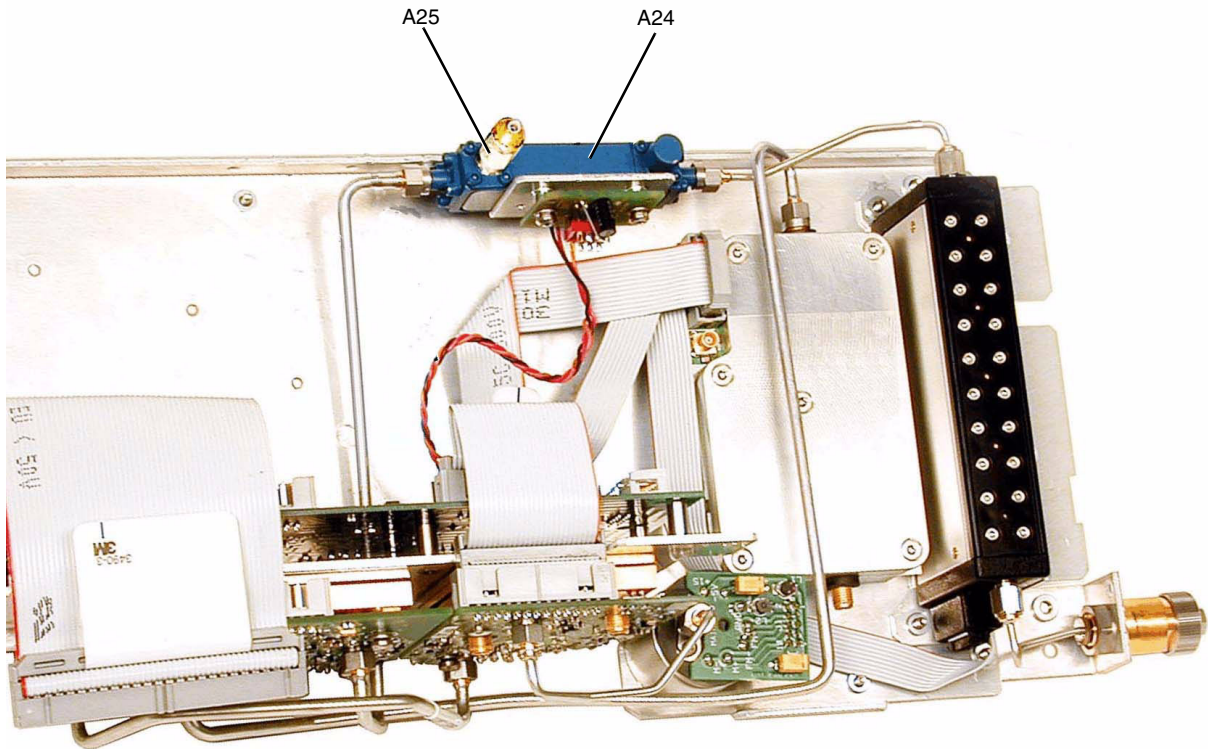
Refer to [Figure 2-34](#) for this procedure.

1. Disconnect the power cord.
2. Remove the covers from the signal generator. Refer to "[Outer Instrument Cover](#)" on page 2-5 and "[Inner Instrument Cover](#)" on page 2-7.
3. Position the signal generator with the A31 Motherboard facing away from you and the RF deck on top.
4. Using the 5/16" open ended wrench, disconnect the A25 40 GHz High Band Detector from the A24 40 GHz High Band Coupler.
5. Using the needle-nose pliers, disconnect W15 from the A25 40 GHz High Band Detector.
6. Remove the A25 40 GHz High Band Detector.

### Replacement Procedure

- Reverse the order of the removal procedure.
- Torque all T-10 screws to 9 in-lbs.
- Torque all RF connectors to 8 in-lbs.
- Perform the post-repair adjustments and performance tests that pertain to this removal procedure.

**Figure 2-34**      **A25 40 GHz High Band Detector**



p-se974a

## A25B Highband Detector Bias Board

### Tools Required

- T-10 driver

### Removal Procedure

Refer to [Figure 2-35](#) for this procedure.

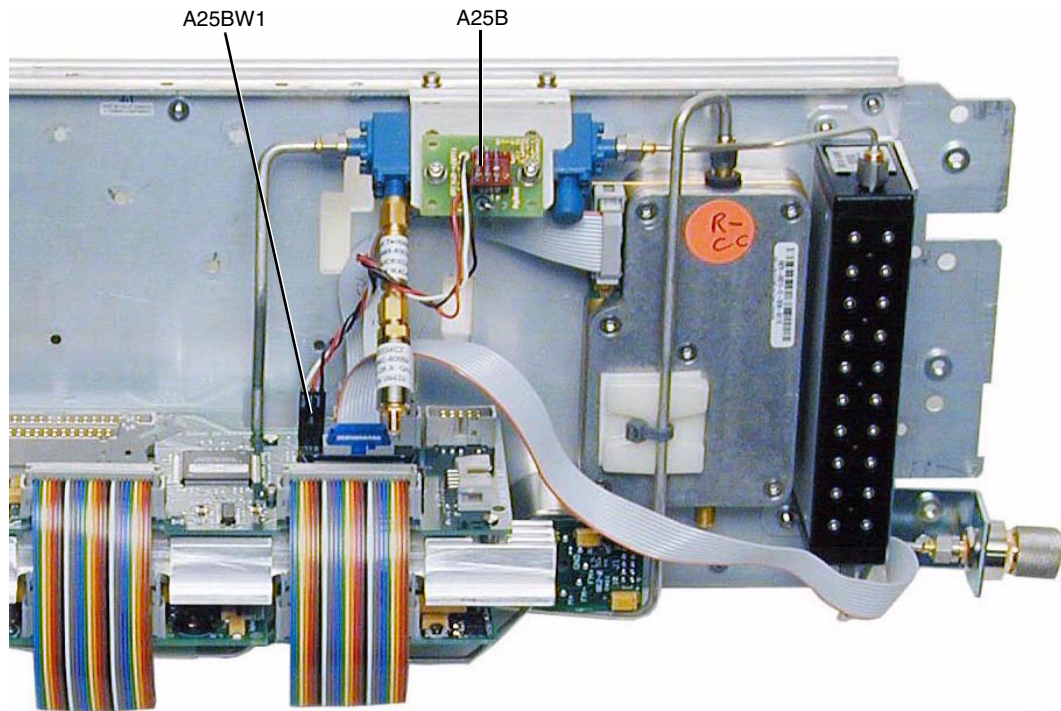
1. Disconnect the power cord.
2. Remove the covers from the signal generator. Refer to "[Outer Instrument Cover](#)" on page 2-5 and "[Inner Instrument Cover](#)" on page 2-7.
3. Position the signal generator with the A31 Motherboard facing away from you and the RF deck on top.
4. Disconnect the A25BW1 bias board power cable from the A26 MID J12.
5. Using the T-10 driver, remove the two screws (1) that attach the A25B Highband Detector Bias Board to the A24 Highband Coupler.
6. Remove the A25B Highband Detector Bias Board.

### Replacement Procedure

- Reverse the order of the removal procedure.
- Torque all T-10 screws to 9 in-lbs.
- Perform the post-repair adjustments and performance tests that pertain to this removal procedure.



**Figure 2-35**      **A25B Highband Detector Bias Board**



p2\_b24



## A26 MID (Microcircuit Interface Deck)

### Tools Required

- T-10 driver

### Removal Procedure

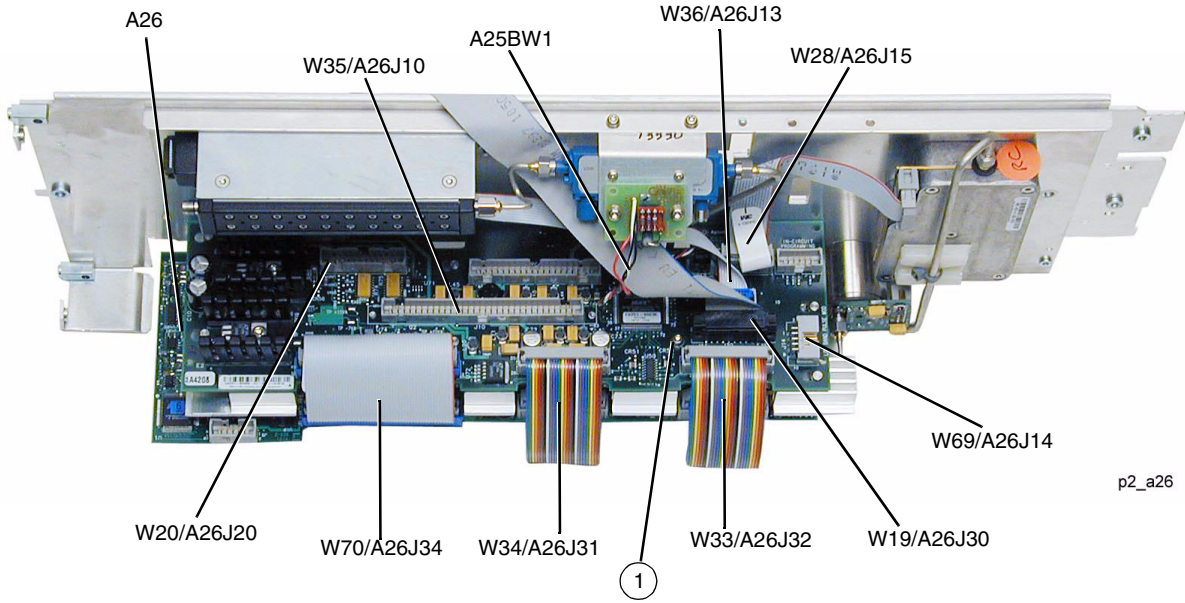
Refer to [Figure 2-36](#) for this procedure.

1. Disconnect the power cord.
2. Remove the covers from the signal generator. Refer to "[Outer Instrument Cover](#)" on page 2-5 and "[Inner Instrument Cover](#)" on page 2-7.
3. Position the signal generator with the A31 Motherboard facing you and the RF deck on top.
4. If you have a 40 GHz signal generator, disconnect the W29 ribbon cable from A26J33.
5. Disconnect the following ribbon cables:
  - W69 from A26J14
  - W28 from A26J15
  - W19 from A26J30
  - W36 from A26J13
  - W33 from A26J32
  - W34 from A26J31
  - W35 from A26J10
  - W70 from A26J34 (E8267C signal generators only)
  - W20 from A26J20
6. Disconnect the A25BW1 power cable from A26J12.
7. Using the T-10 driver, loosen the screw (1) that secures the A26 MID to the RF deck.
8. Slide the A26 MID towards the front panel until the locking standoffs are free.
9. Remove the A26 MID from the RF bracket.

### Replacement Procedure

- Reverse the order of the removal procedure.
- Torque all T-10 screws to 9 in-lbs.
- Perform the post-repair adjustments and performance tests that pertain to this removal procedure.

Figure 2-36 A26 MID



p2\_a26

## A27 40 GHz Doubler (Option 540 Models Only)

### Tools Required

- T-10 driver
- 5/16" open ended wrench

### Removal Procedure

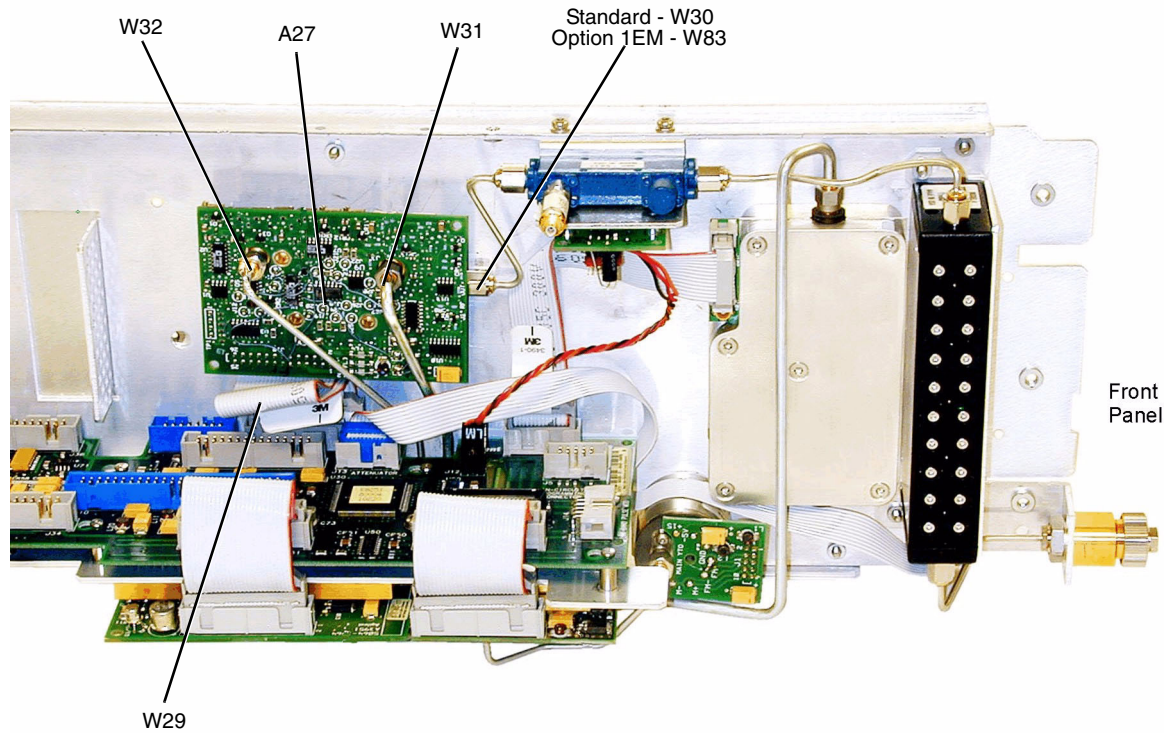
Refer to [Figure 2-37](#) for this procedure.

1. Disconnect the power cord.
2. Remove the covers from the signal generator. Refer to "[Outer Instrument Cover](#)" on page 2-5 and "[Inner Instrument Cover](#)" on page 2-7.
3. Position the signal generator with the A31 Motherboard facing away from you and the RF deck on top.
4. Using the 5/16" open ended wrench, disconnect the following RF cables:
  - **Standard** - W30 from A27 40 GHz Doubler or **Option 1EM** - W83 from A27 40 GHz Doubler
  - W31 from A27J3
  - W32 from A27J1
5. Using the T-10 driver, remove the two screws that attach the A27 40 GHz Doubler to the side panel.
6. Disconnect the W29 ribbon cable from the A27 40 GHz Doubler's board.
7. Remove the A27 40 GHz Doubler from the RF deck.

### Replacement Procedure

- Reverse the order of the removal procedure.
- Torque all T-10 screws to 9 in-lbs.
- Torque all RF connectors to 8 in-lbs.
- Perform the post-repair adjustments and performance tests that pertain to this removal procedure.

**Figure 2-37**      **A27 40 GHz Doubler**



p-se967a

## A28 YIG Oscillator

### Tools Required

- T-10 driver
- 5/16" open ended wrench

### Removal Procedure

Refer to [Figure 2-38](#) for this procedure.

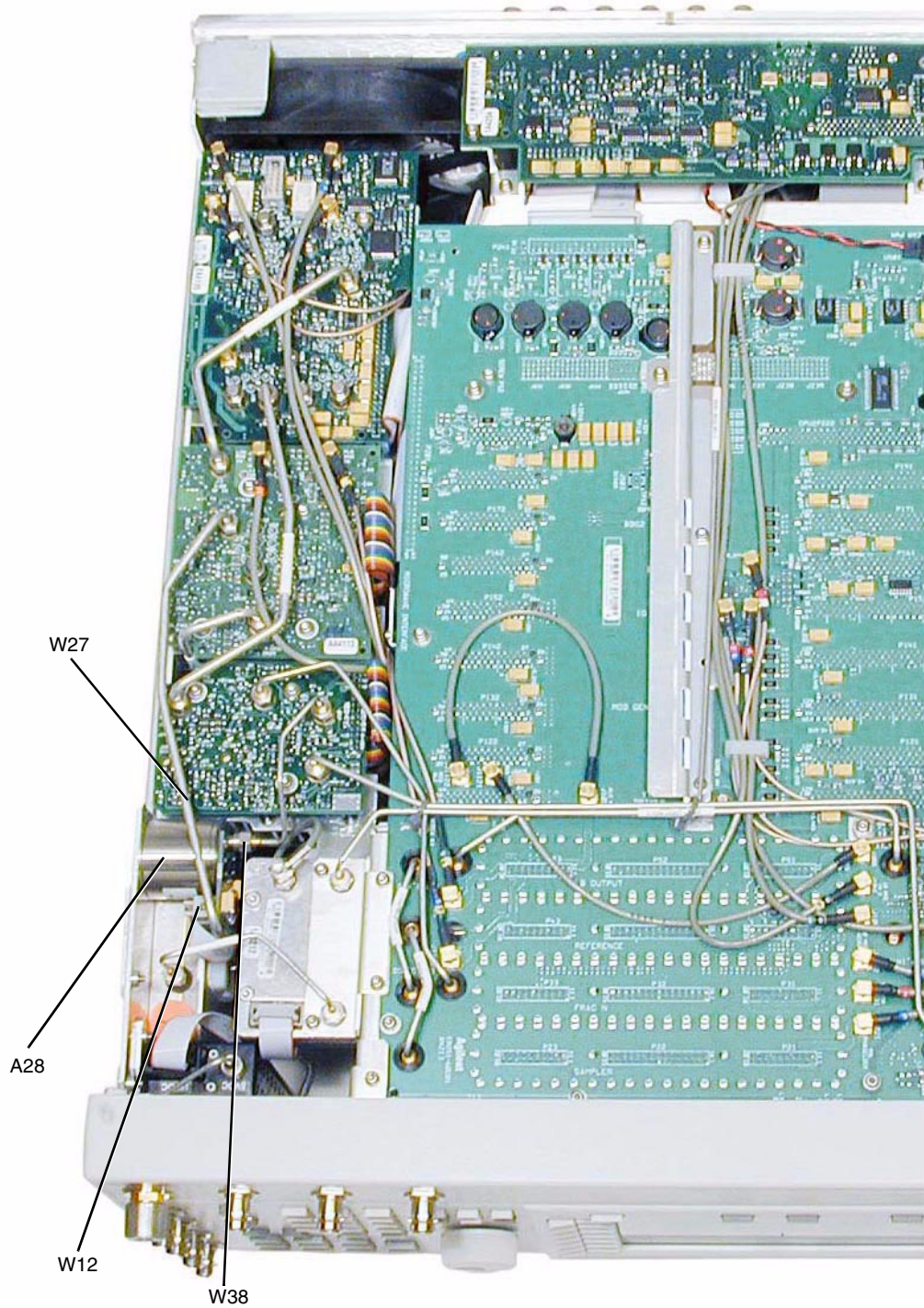
1. Disconnect the power cord.
2. Remove the covers from the signal generator. Refer to "[Outer Instrument Cover](#)" on page 2-5 and "[Inner Instrument Cover](#)" on page 2-7.
3. Position the signal generator with the A31 Motherboard facing you and the RF deck on top.
4. Using the 5/16" open ended wrench, disconnect the W38 RF cable from the A28 YIG Oscillator.
5. Disconnect the W12 ribbon cable from the A28 YIG Oscillator's driver board.
6. Using the T-10 driver, remove the two screws (1) that attach the A28 YIG Oscillator to the side panel.
7. Using the 5/16" open ended wrench, disconnect the W27 RF cable from the A30 Modulation Filter with High Power.
8. Remove the A28 YIG Oscillator.

### Replacement Procedure

- Reverse the order of the removal procedure.
- Torque all T-10 screws to 9 in-lbs.
- Torque all RF connectors to 8 in-lbs.
- Perform the post-repair adjustments and performance tests that pertain to this removal procedure.



Figure 2-38 A28 YIG Oscillator



## A29 20 GHz Doubler

### Tools Required

- T-10 driver
- 5/16" open ended wrench

### Removal Procedure

Refer to [Figure 2-39](#) for this procedure.

1. Disconnect the power cord.
2. Remove the covers from the signal generator. Refer to "[Outer Instrument Cover](#)" on page 2-5 and "[Inner Instrument Cover](#)" on page 2-7.
3. Position the signal generator with the A31 Motherboard facing you and the RF deck on top.
4. Using the 5/16" open ended wrench, disconnect the following RF cables:
  - W38 from A29J1
  - W39 from A29J4
  - W40 from A29J3
5. Using the 5/16" open ended wrench, disconnect the following RF cable according to the signal generator you have.

**E8247C/57C:** Disconnect the W41 RF cable from the A29J2.

**E8267C:** Disconnect the W77 RF cable from the A29J2.

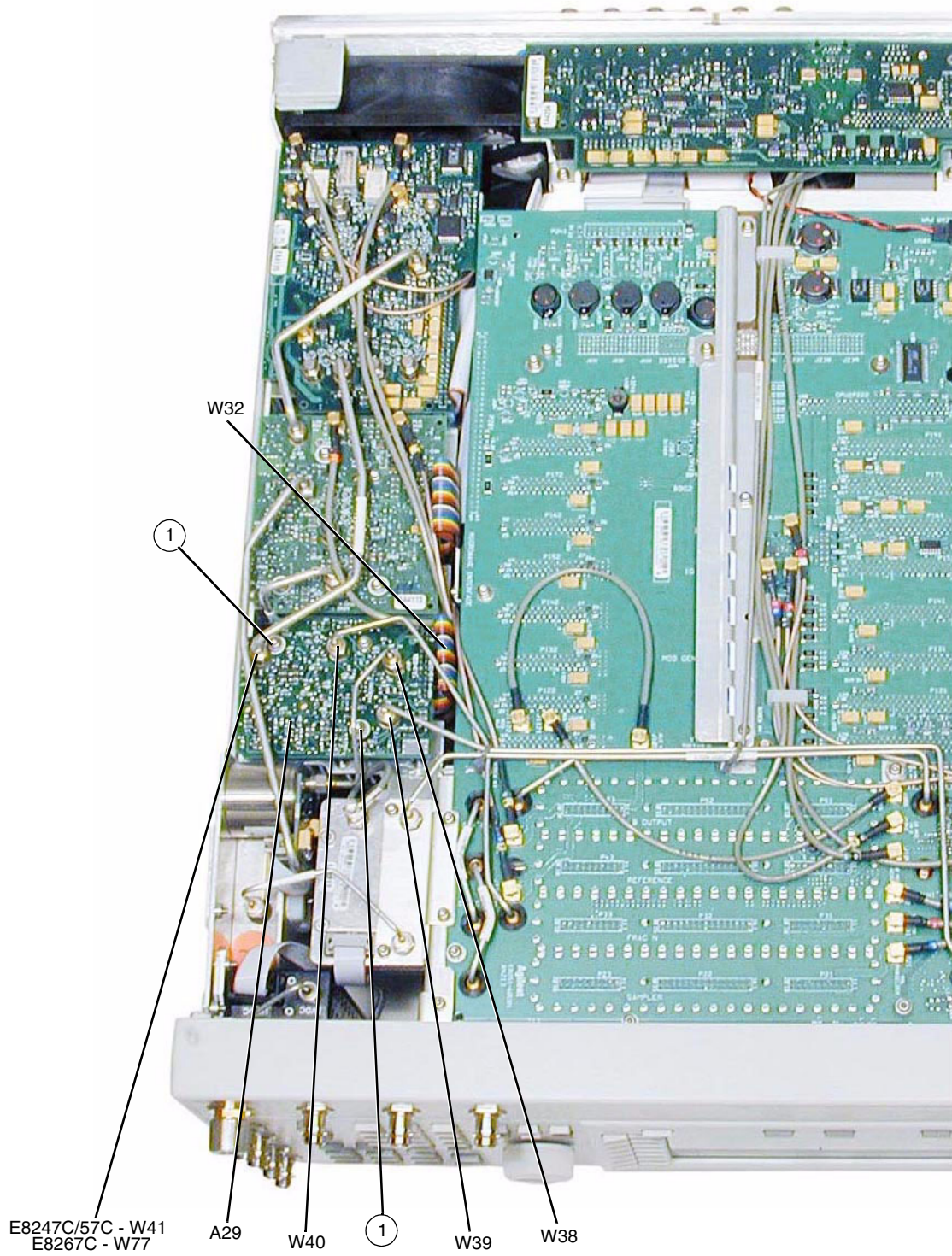
6. Using the T-10 driver, remove the two screws (1) that attach the A29 20 GHz Doubler to the RF deck.
7. Disconnect the W32 ribbon cable from the A29 20 GHz Doubler.
8. Remove the A29 20 GHz Doubler from the RF deck.

### Replacement Procedure

- Reverse the order of the removal procedure.
- Torque all T-10 screws to 9 in-lbs.
- Torque all RF connectors to 8 in-lbs.
- Perform the post-repair adjustments and performance tests that pertain to this removal procedure.



Figure 2-39 A29 20 GHz Doubler





## A30 Modulation Filter (Standard and Option 1EA)

### Tools Required

- T-10 driver
- 5/16" open ended wrench

### Removal Procedure

Refer to [Figure 2-40](#) for this procedure.

1. Disconnect the power cord.
2. Remove the covers from the signal generator. Refer to "[Outer Instrument Cover](#)" on page 2-5 and "[Inner Instrument Cover](#)" on page 2-7.
3. Position the signal generator with the A31 Motherboard facing away from you and the RF deck on top.
4. Disconnect the following flexible cables:
  - W17 from A30J7
  - W13 from A30J6
5. Using the 5/16" open ended wrench, disconnect the following RF cable according to the signal generator you have.

**E8247C/57C:** Disconnect the W41 RF cable from A30J1.

**E8267C:** Disconnect the W78 RF cable from A30J1.

6. Disconnect the W33 ribbon cable from the A30 Modulator Filter.
7. Using the 5/16" open ended wrench, disconnect the following RF cable according to the signal generator you have.

**Option 520 Standard:** Disconnect the W74 RF cable from A30J2.

**Option 540 Standard:** Disconnect the W31 RF cable from A30J2.

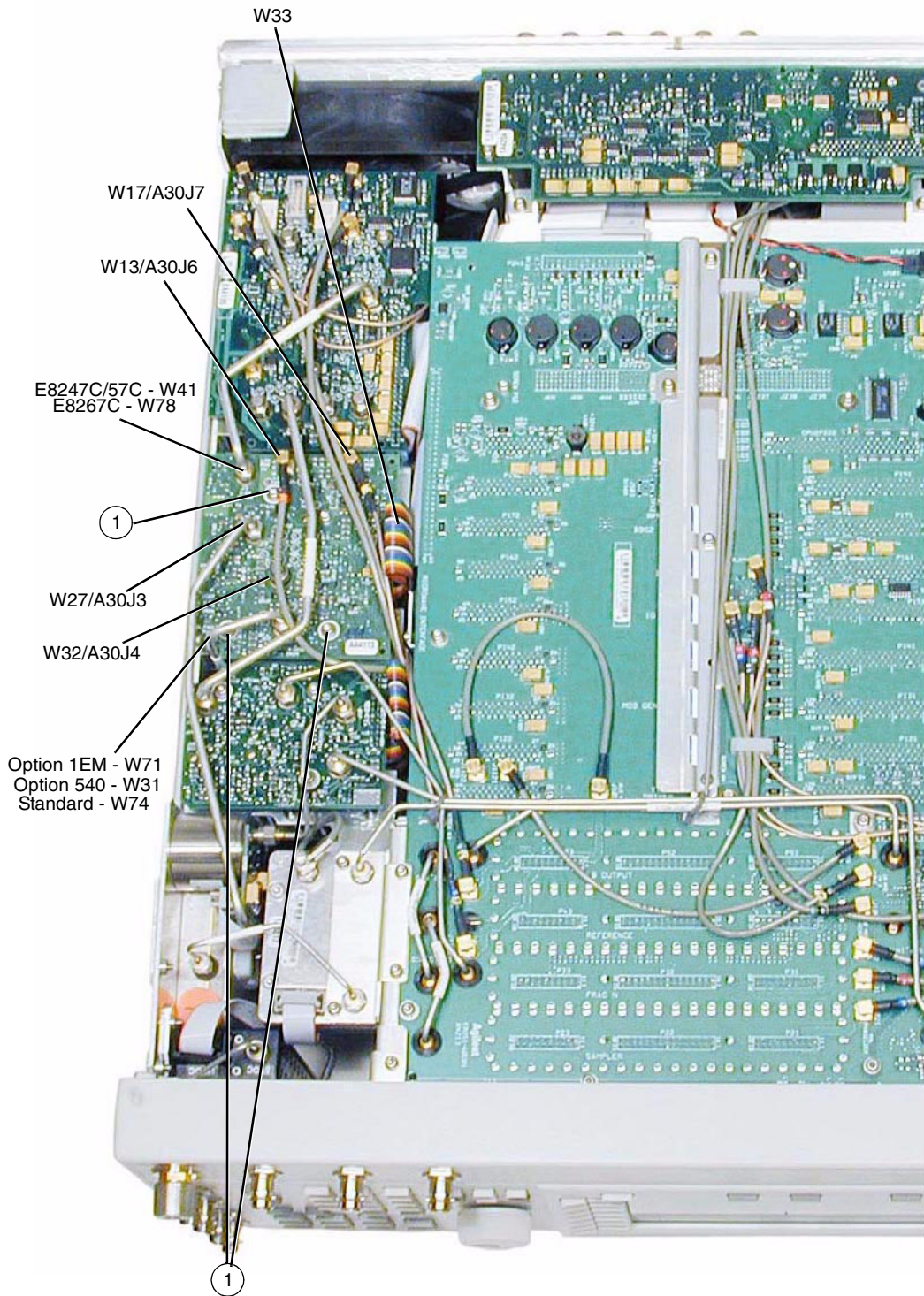
**Option 1EM:** Disconnect the W71 RF cable from A30J2.

8. Using the 5/16" open ended wrench, disconnect the following RF cables:
  - W27 from A30J3
  - W32 from A30J4
9. Using the T-10 driver, remove the three screws (1) that attach the A30 Modulator Filter to the RF bracket.
10. Remove the A30 Modulator Filter from the RF deck.

## Replacement Procedure

- Reverse the order of the removal procedure.
- Torque all T-10 screws to 9 in-lbs.
- Torque all RF connectors to 8 in-lbs.
- Perform the post-repair adjustments and performance tests that pertain to this removal procedure.

Figure 2-40 A30 Modulator Filter



## A31 Motherboard (E8247C/57C)

### Tools Required

- T-10 driver
- 5/16" open ended wrench
- needle-nose plier

### Removal Procedure

Refer to [Figure 2-41](#) for this procedure.

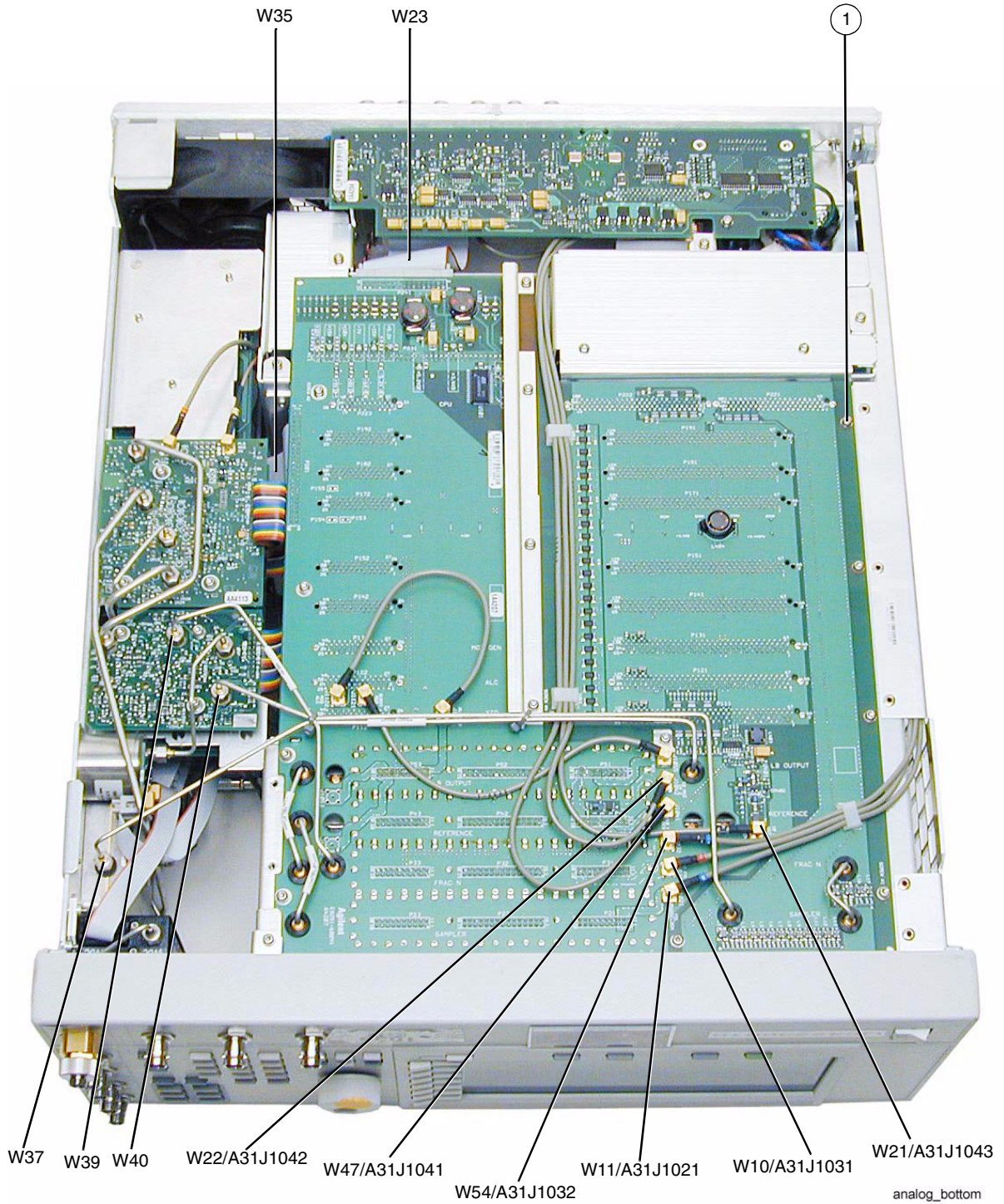
1. Disconnect the power cord.
2. Remove the covers from the signal generator. Refer to "[Outer Instrument Cover](#)" on page 2-5 and "[Inner Instrument Cover](#)" on page 2-7.
3. Position the signal generator with the A31 Motherboard facing you and the RF deck on top.
4. Remove the front panel. Refer to "[Front Panel](#)" on page 2-9.
5. Remove the assemblies that are inserted into the A31 Motherboard. Refer to "[A5 Sampler, A6 Frac-N, A7 Reference \(Standard and Option UNR\), and A8 Output](#)" on page 2-22, "[A9 YIG Driver](#)" on page 2-24, "[A10 ALC](#)" on page 2-27, "[A11 Pulse/Analog Modulation Generator](#)" on page 2-29, "[A14 Baseband Generator \(E8267C Models Only\)](#)" on page 2-34, "[A18 CPU](#)" on page 2-39, and "[A35 3-20 GHz I/Q Modulator \(E8267C Models Only\)](#)" on page 2-96.
6. Using the 5/16" open ended wrench, disconnect the following RF cables:
  - W40 from A29 20 GHz Doubler J3
  - W39 from A29 20 GHz Doubler J4
  - W37 from A23 Low Band Coupler/Detector
7. Using the needle-nose pliers, disconnect the following flexible cables:
  - W21 from A31J1043
  - W10 from A31J1031
  - W11 from A31J1021
  - W54 from A31J1032
  - W47 from A31J1041
  - W22 from A31J1042
8. Disconnect the W23 ribbon cable from the A21 Rear Panel Interface while removing the A31 Motherboard from the chassis.
9. Disconnect the W35 ribbon cable from the A26 MID J10.
10. Using the T-10 driver, remove the 15 screws (1) that hold the A31 Motherboard to the chassis.

## **Replacement Procedure**

- Reverse the order of the removal procedure.
- Torque all T-10 screws to 9 in-lbs.
- Torque all RF connectors to 8 in-lbs.
- Perform the post-repair adjustments and performance tests that pertain to this removal procedure.



Figure 2-41 A31 Motherboard (E8247C/57C)



## A31 Motherboard (E8267C)

### Tools Required

- T-10 driver
- 5/16" open ended wrench
- needle-nose pliers

### Removal Procedure

Refer to [Figure 2-41](#) for this procedure.

1. Disconnect the power cord.
2. Remove the covers from the signal generator. Refer to "[Outer Instrument Cover](#)" on page 2-5 and "[Inner Instrument Cover](#)" on page 2-7.
3. Position the signal generator with the A31 Motherboard facing you and the RF deck on top.
4. Remove the front panel. Refer to "[Front Panel](#)" on page 2-9.
5. Remove the assemblies that are inserted into the A31 Motherboard. Refer to "[A5 Sampler, A6 Frac-N, A7 Reference \(Standard and Option UNR\), and A8 Output](#)" on page 2-22, "[A9 YIG Driver](#)" on page 2-24, "[A10 ALC](#)" on page 2-27, "[A11 Pulse/Analog Modulation Generator](#)" on page 2-29, "[A14 Baseband Generator \(E8267C Models Only\)](#)" on page 2-34, "[A18 CPU](#)" on page 2-39, and "[A35 3-20 GHz I/Q Modulator \(E8267C Models Only\)](#)" on page 2-96.
6. Using the 5/16" open ended wrench, disconnect the following RF cables:
  - W67 from Rear Panel (.25-3.2 GHz COH CARRIER)
  - W40 from  
A29 20 GHz Doubler J3
  - W39 from A29 20 GHz Doubler J4
  - W76 from A12 Pulse Modulator Board
7. Using the needle-nose pliers, disconnect the following flexible cables:
  - W21 from A31J1043
  - W10 from A31J1031
  - W11 from A31J1021
  - W54 from A31J1032
  - W47 from A31J1041
  - W22 from A31J1042
  - W60 from A31J1052
  - W61 from A31J1053
  - W51 from A31J500
  - W52 from A31J501
  - W53 from A31J502

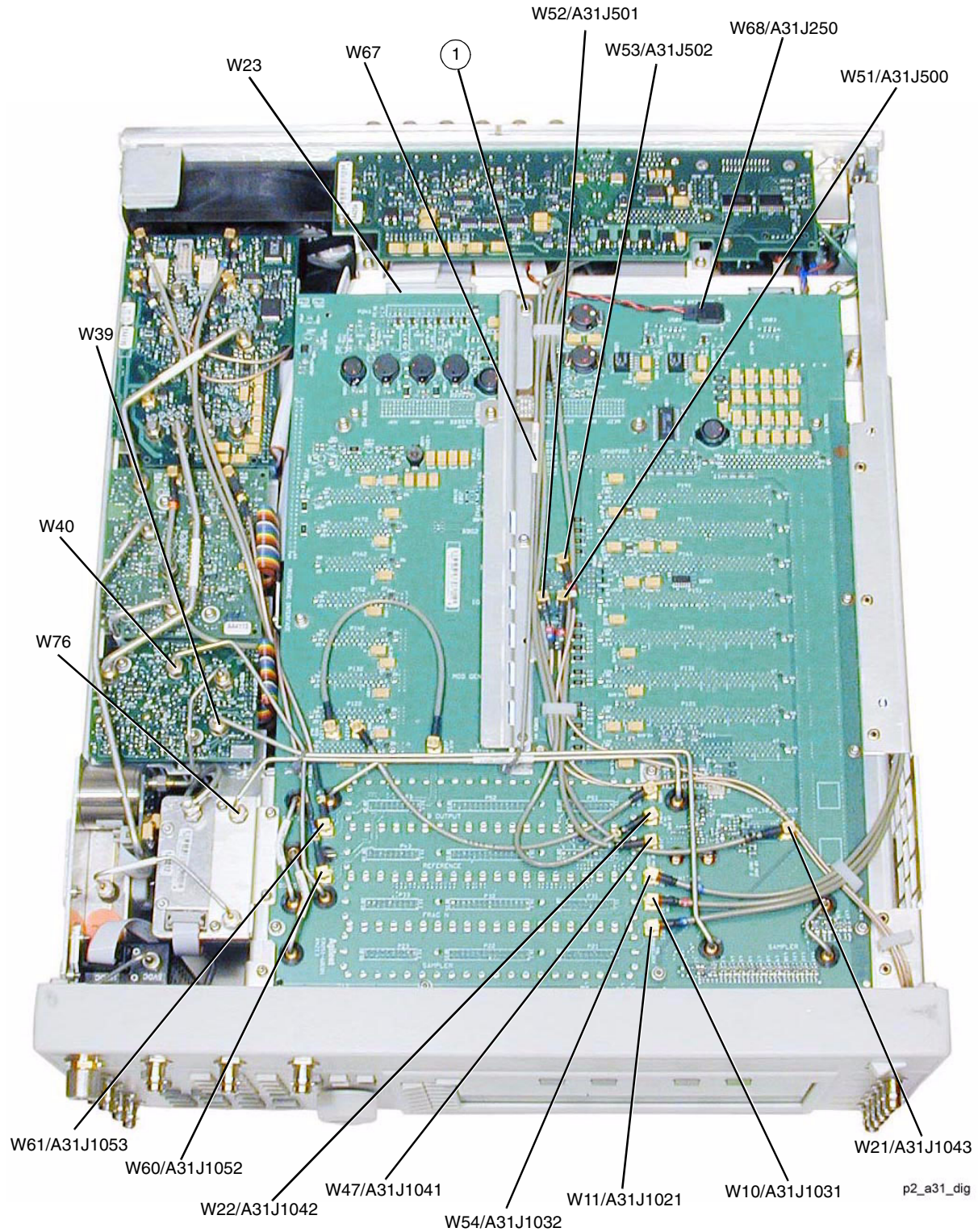
8. Using the needle-nose pliers, disconnect the W68 wire cable from A31J250
9. Disconnect the W23 ribbon cable from the A21 Rear Panel Interface while removing the A31 Motherboard from the chassis.
10. Disconnect the W35 ribbon cable (not shown in [Figure 2-42](#)) from the A26 MID J10.
11. Using the T-10 driver, remove the 15 screws (1) that hold the A31 Motherboard to the chassis.

## **Replacement Procedure**

- Reverse the order of the removal procedure.
- Torque all T-10 screws to 9 in-lbs.
- Torque all RF connectors to 8 in-lbs.
- Perform the post-repair adjustments and performance tests that pertain to this removal procedure.



Figure 2-42 A31 Motherboard (E8267C)



*This page intentionally left blank*

## A32 10 MHz Crystal Oscillator (Option UNR)

### Tools Required

- T-10 driver
- needle-nose plier

### Removal Procedure

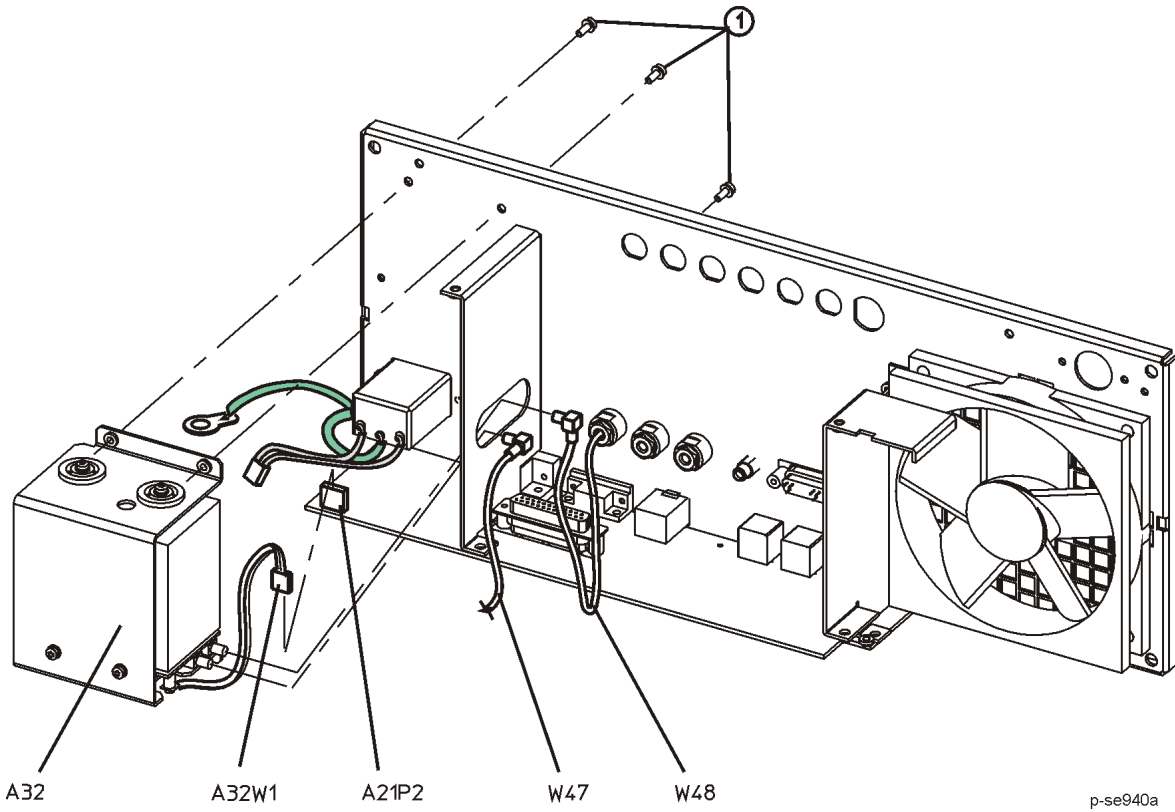
Refer to [Figure 2-43](#) for this procedure.

1. Disconnect the power cord.
2. Remove the covers from the signal generator. Refer to "[Outer Instrument Cover](#)" on page 2-5 and "[Inner Instrument Cover](#)" on page 2-7.
3. Position the signal generator with the Rear Panel facing you.
4. Using the needle-nose pliers, disconnect the W47 flexible cable (A31 Motherboard J1041) from A32J2.
5. Using the needle-nose pliers, disconnect the W48 flexible cable (10 MHz EFC) from A32J1.
6. Disconnect the A32W1 bias cable from the A21 Rear Panel Interface P2.
7. Using the T-10 driver, remove the three screws (1) that attach the A32 10 MHz Crystal Oscillator to the rear panel.
8. Remove the A32 10 MHz Crystal Oscillator.

### Replacement Procedure

- Reverse the order of the removal procedure.
- Torque all T-10 screws to 9 in-lbs.
- Perform the post-repair adjustments and performance tests that pertain to this removal procedure.

Figure 2-43 A32 Crystal Oscillator



p-se940a

## A33 6 dB PAD

### Tools Required

- 5/16" open ended wrench
- needle-nose pliers

### Removal Procedure

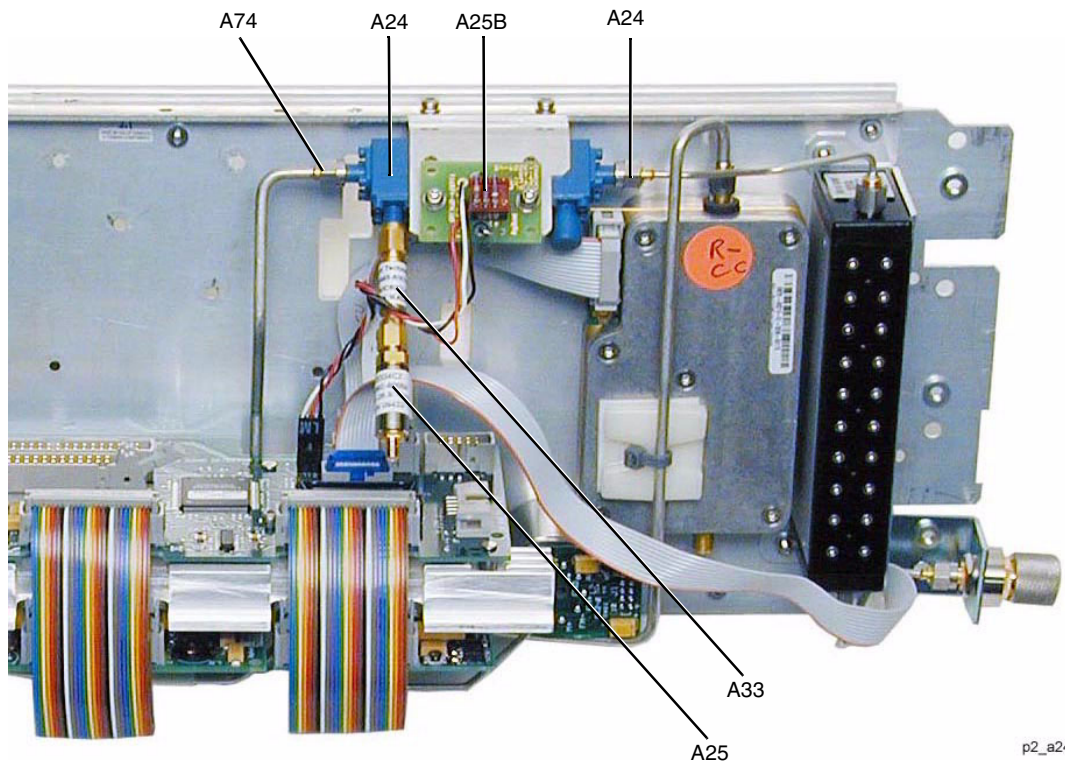
Refer to [Figure 2-44](#) for this procedure.

1. Disconnect the power cord.
2. Remove the covers from the signal generator. Refer to "[Outer Instrument Cover](#)" on page 2-5 and "[Inner Instrument Cover](#)" on page 2-7.
3. Using the 5/16" open ended wrench, disconnect the A33 6 dB PAD from the A24 High Band Coupler.
4. Using the 5/16" open ended wrench, disconnect the A33 6 dB PAD from the A25 High Band Detector.
5. Remove the A33 6 dB PAD.

### Replacement Procedure

- Reverse the order of the removal procedure.
- Torque all RF connectors to 8 in-lbs.
- Perform the post-repair adjustments and performance tests that pertain to this removal procedure.

Figure 2-44 A33 6 dB PAD



p2\_a24



## A34 Internal Hard Drive (E8267C Models Only)

### Tools Required

- T-10 driver

### Removal Procedure

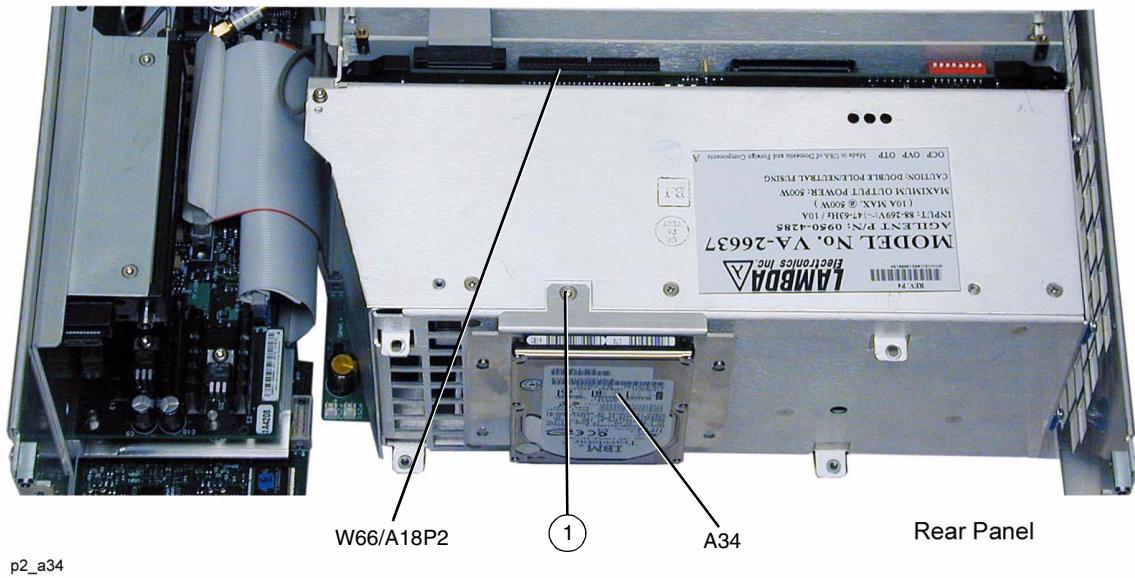
Refer to [Figure 2-45](#) for this procedure.

1. Disconnect the power cord.
2. Remove the covers from the signal generator. Refer to "[Outer Instrument Cover](#)" on page 2-5 and "[Inner Instrument Cover](#)" on page 2-7.
3. Remove the rear panel. Refer to "[Rear Panel \(Standard\)](#)" on page 2-44 or "[Rear Panel \(Option 1EM\)](#)" on page 2-47.
4. Disconnect the W66 ribbon cable from the A18 CPU P2.
5. Using the T-10 driver, remove the screw (1) that attaches the A34 Internal Hard Drive to the A19 Power Supply.
6. Remove the A34 Internal Hard Drive.

### Replacement Procedure

- Reverse the order of the removal procedure.
- Torque all T-10 screws to 9 in-lbs.
- Perform the post-repair adjustments and performance tests that pertain to this removal procedure.

Figure 2-45 A34 Internal Hard Drive (Option 005)





## A35 3-20 GHz I/Q Modulator (E8267C Models Only)

### Tools Required

- needle-nose pliers

### Removal Procedure

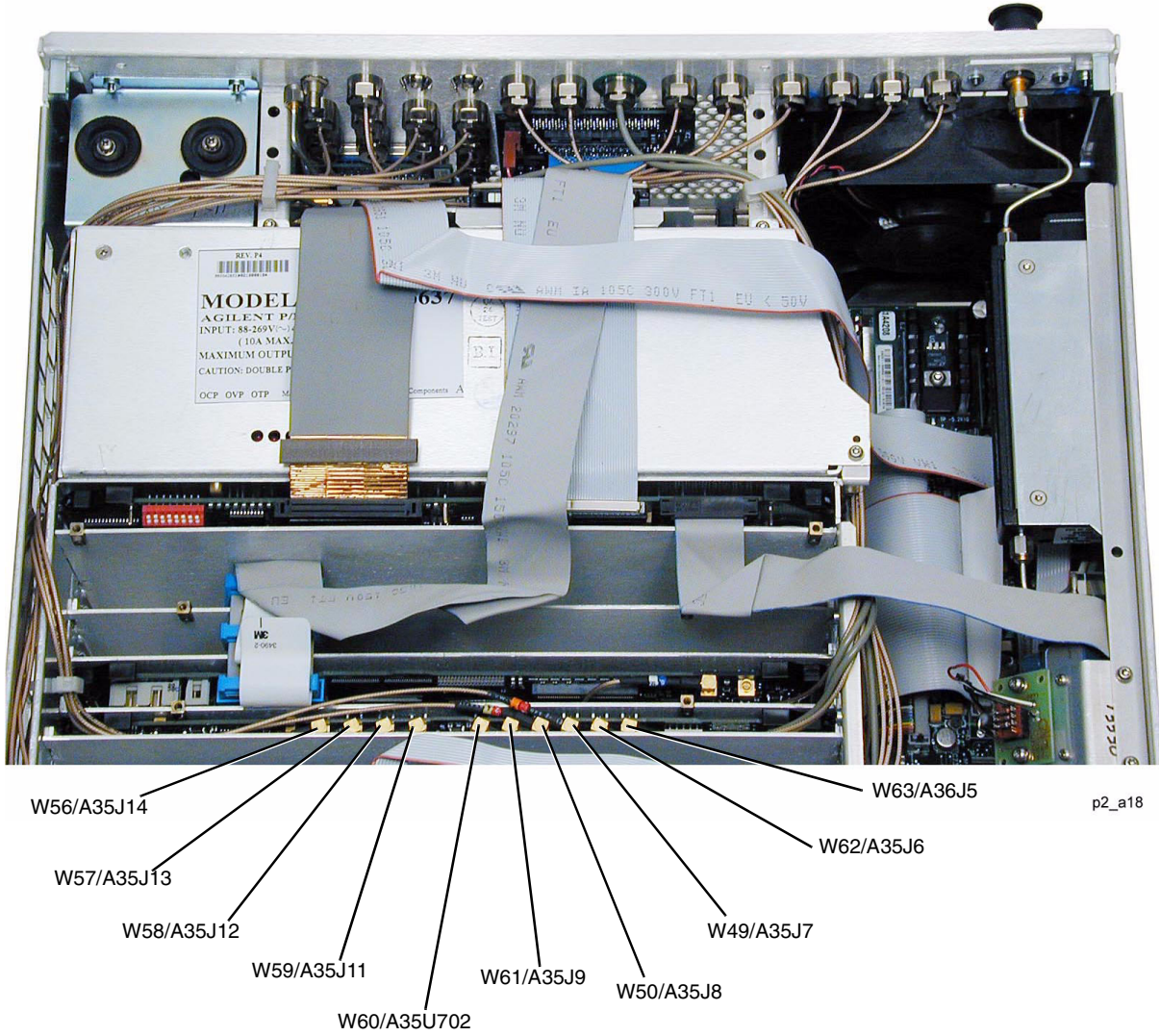
Refer to [Figure 2-46](#) for this procedure.

1. Disconnect the power cord.
2. Remove the covers from the signal generator. Refer to "[Outer Instrument Cover](#)" on page 2-5 and "[Inner Instrument Cover](#)" on page 2-7.
3. Position the signal generator with the front panel facing you.
4. Using the T-10 driver, remove the four screws from the Baseband Generator cover.
5. Using the needle-nose pliers, disconnect the following flexible cables:
  - W63 from A35J5
  - W62 from A35J6
  - W49 from A35J7
  - W50 from A35J8
  - W61 from A35J9
  - W60 from A3510
  - W59 from A35J11
  - W58 from A35J12
  - W57 from A35J13
  - W56 from A35J14
6. Lift the retention levers and disconnect the A35 3-20 GHz I/Q Modulator from the A31 Motherboard.
7. Lift the A35 3-20 GHz I/Q Modulator out of the slot.

### Replacement Procedure

- Reverse the order of the removal procedure.
- Perform the post-repair adjustments and performance tests that pertain to this removal procedure.

Figure 2-46 A35 3-20 GHz I/Q Modulator



## **B1 Fan**

### **Tools Required**

- T-10 driver
- 5/16" open ended wrench

### **Removal Procedure**

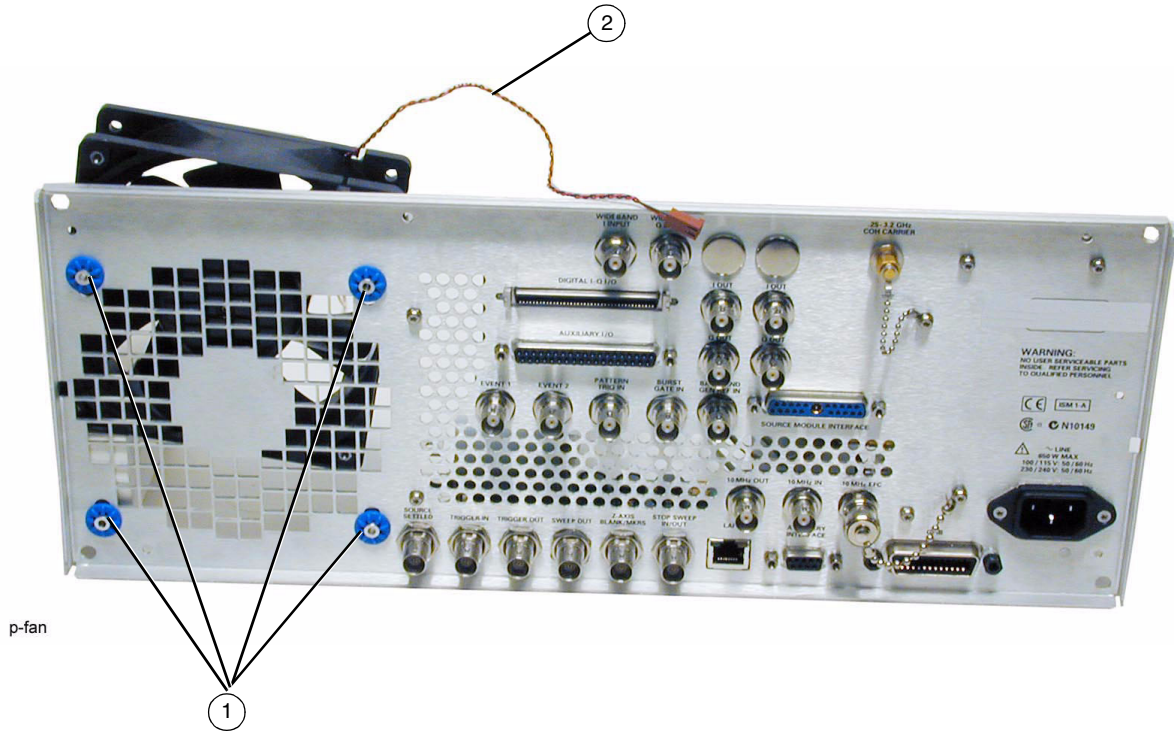
Refer to [Figure 2-47](#) for this procedure.

1. Disconnect the power cord.
2. Remove the covers from the signal generator. Refer to "[Outer Instrument Cover](#)" on page 2-5 and "[Inner Instrument Cover](#)" on page 2-7.
3. Position the signal generator with the rear panel facing you.
4. Using the 5/16" open ended wrench, disconnect the W73 RF cable from the AT1 115 dB Attenuator and the RF Out (Option 1EM signal generators only).
5. Using the T-10 driver, remove the four screws (1) that attach the B1 Fan to the rear panel.
6. Disconnect the fan cable (2) from the A31 Motherboard P251.
7. Remove the B1 Fan.

### **Replacement Procedure**

- Reverse the order of the removal procedure.
- Torque all T-10 screws to 9 in-lbs.
- Torque all RF connectors to 8 in-lbs.
- Perform the post-repair adjustments and performance tests that pertain to this removal procedure.

Figure 2-47 B1 Fan



p-fan



---

## **3 Replaceable Parts**

## Ordering Information

To order a part, do the following:

1. Determine the part number.
2. Determine the quantity required.
3. Mail this information to the nearest Agilent Technologies office or, in the U.S., call the hot-line number listed in the following section.

To order a part not listed in the replaceable parts lists, mail the following information to the nearest Agilent Technologies office or, in the United States, call the hot-line number listed in the following section.

- the instrument model number
- the serial number and options, if any (see rear panel)
- a description of the part
- a description of the part's function
- the quantity required

### **Call (800) 227-8164 to Order Parts Fast (U.S. Only)**

When you have gathered the information required to place an order, contact Agilent Technologies' direct ordering team by calling the toll-free hot-line number shown above. Orders may be placed Monday through Friday, 6 AM to 5 PM (Pacific Standard Time).

The parts specialists have direct on-line access to replacement parts inventory corresponding to the replaceable parts lists in this manual. Four day delivery time is standard; there is a charge for hot-line one-day delivery.

This information applies to the United States only. Outside the United States, you must contact the nearest Agilent Technologies sales and service office.

---

## Save Money with Rebuilt-Exchange Assemblies

Under the rebuilt-exchange assembly program, certain factory-repaired and tested assemblies are available on a trade-in basis. These assemblies cost less than a new assembly, and meet all factory specifications required of a new assembly.

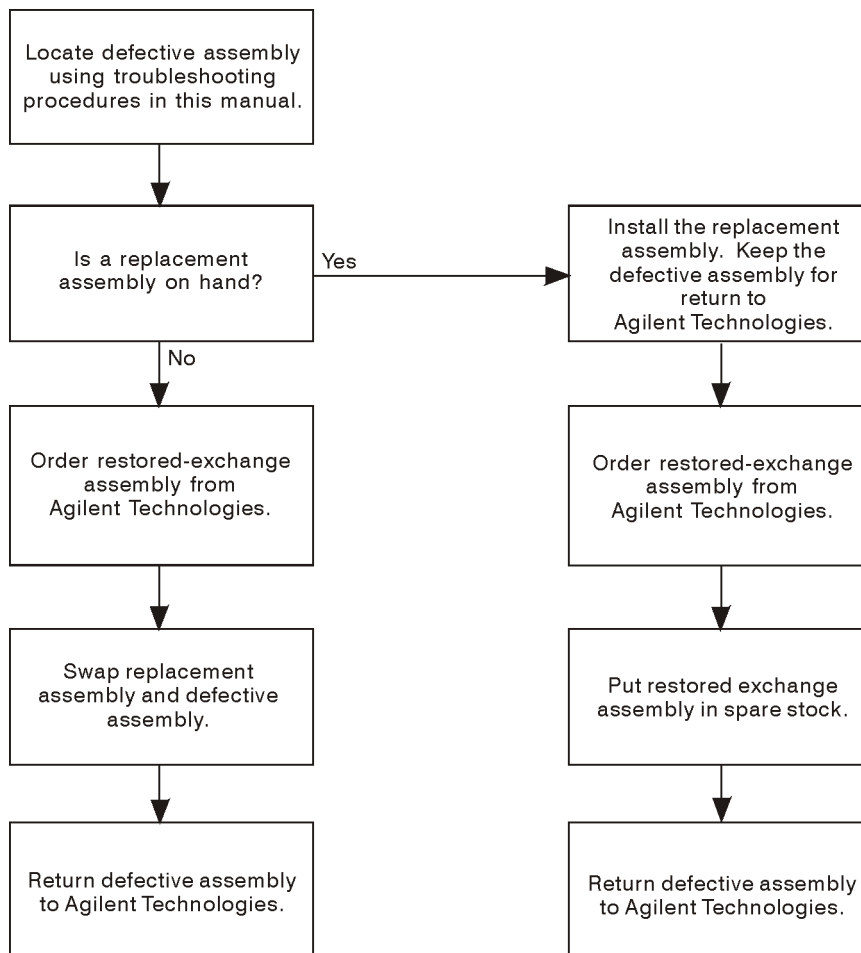
The defective assembly must be returned for credit under the terms of the rebuilt-exchange assembly program. The figure below illustrates the assembly exchange procedure in flowchart format.

---

**NOTE** When ordering replacement parts, ask about exchange assemblies.

---

**Figure 3-1 Assembly Exchange Procedure**



p\_sk770a



## Shipping a Defective Assembly Back to Agilent Technologies

1. When you receive the rebuilt assembly, be careful not to damage the box in which it was shipped. You will use that box to return the defective assembly. The box you receive should contain the following:
  - the rebuilt assembly
  - an exchange assembly failure report
  - a return address label
2. Complete the failure report.
3. Place the failure report and the defective assembly in the box. Be sure to remove the enclosed return address label.
4. Seal the box with tape.

If you are inside the United States, stick the pre-printed return address label over the label that is already on the box and return the box to Agilent Technologies. (Agilent Technologies pays postage on boxes mailed within the United States.)

If you are outside the United States, do not use the return address label; instead, address the box to the nearest Agilent Technologies sales and service office.

## Frequency, Hardware, and Personality Options

This section lists the options available with the Agilent PSG Family signal generator.

<b>Frequency Options</b>	
520	250 kHz to 20 GHz frequency range
540	250 kHz to 40 GHz frequency range (E8247C/57C only)

<b>Hardware Options</b>	
1E1	Adds output step attenuator for extended range to -135 dBm
1E6	Adds fast pulse < 3.2 GHz
1EA	Adds high RF output power +20 dBm at 20 GHz, +14 dBm at 40 GHz
1ED	Specifies Type-N RF output connector (20 GHz models only)
1EM	Moves all front panel connectors to rear panel
UNR	Adds enhanced close-in phase noise
002	Adds internal baseband generator with 32 Mega sample memory (E8267C only)
005	Adds 6 GB hard drive (Option 002 required) (E8267C only)
007	Adds analog ramp sweep

## Assemblies and Hardware Options

Assembly	E8247C E8257C		E8267C Option 520	
	Part Number	Page Number	Part Number	Page Number
A1 Keyboard	E8251-60058	3-9	E8251-60058	3-9
A2 Display	2090-0375	3-9	2090-0375	3-9
A2DS1 Display Backlight	1513-5204	3-9	1513-5204	3-9
A3 Power Switch	E8251-60042	3-9	E8251-60042	3-9
A4 Inverter	0950-3757	3-9	0950-3757	3-9
A5 Sampler	E8251-60043	3-10	E8251-60043	3-11
A6 Frac-N	E8251-60079	3-10	E8251-60079	3-11
A7 Reference	E8251-60073	3-10	E8251-60073	3-11
or A7 Reference (Option UNR)	E8251-60048	3-10	E8251-60048	3-11
A8 Output	E8251-60046	3-10	N/A	
A8 Output (E8267C Only)	N/A		E8251-60205	3-11
A9 YIG Driver	E8251-60080	3-10	E8251-60080	3-11
A10 ALC	E8251-60202	3-10	E8251-60202	3-11
A11 Pulse/Analog Modulation Generator	E8251-60206	3-10	E8251-60206	3-11
A12 Pulse Modulator Board (Option 1E6)	N/A		E8251-60064	3-11 and 3-17
A13 I/Q MUX	N/A		E8251-60208	3-17 and 3-15
A14 Baseband Generator (Option 002)	N/A		E4400-60501	3-11
A17 Baseband Generator Interface	N/A		E4400-60506	3-11 and 3-13
A18 CPU	E8251-60006	3-10 and 3-18	E8251-60006	3-11 and 3-18
A18BT1 Lithium Battery	1420-0314	3-18	1420-0314	3-18
A19 Power Supply	0950-3700	3-10	0950-4285	3-11
A20 SMI (Source Module Interface)	E8251-60211	3-10 and 3-12	E8251-60211	3-11 and 3-13

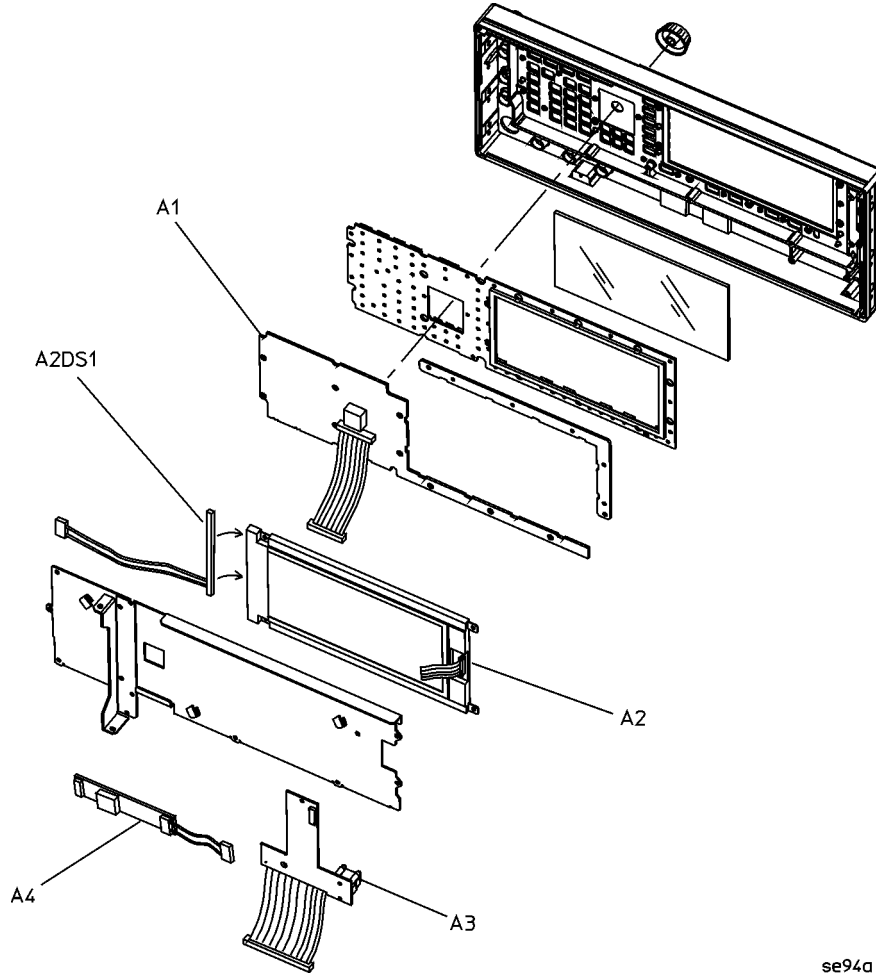
<b>Assembly</b>	<b>E8247C E8257C</b>		<b>E8267C Option 520</b>	
A21 Rear Panel Interface	E8251-60203	<a href="#">3-16</a> and <a href="#">3-12</a>	E8251-60203	<a href="#">3-17</a> and <a href="#">3-13</a>
A22 Line Module	5064-5053	<a href="#">3-16</a> and <a href="#">3-12</a>	9135-5695	<a href="#">3-17</a> and <a href="#">3-13</a>
A23 Lowband Coupler/Detector	E8251-60010	<a href="#">3-10</a> , <a href="#">3-16</a> and <a href="#">3-14</a>	E8251-60210	<a href="#">3-11</a> , <a href="#">3-17</a> and <a href="#">3-15</a>
A24 20 GHz Highband Coupler	0955-0148	<a href="#">3-10</a> and <a href="#">3-14</a>	0955-0148	<a href="#">3-11</a> and <a href="#">3-15</a>
A24 40 GHz Highband Coupler	0955-1136	<a href="#">3-10</a> and <a href="#">3-14</a>	N/A	
A25 20 GHz Highband Detector	08360-60147	<a href="#">3-10</a> and <a href="#">3-14</a>	08360-60147	<a href="#">3-11</a> and <a href="#">3-15</a>
A25 40 GHz Highband Detector	08360-60148	<a href="#">3-10</a> and <a href="#">3-14</a>	N/A	
A25B Highband Detector Bias Board	08360-60091	<a href="#">3-10</a> and <a href="#">3-14</a>	08360-60091	<a href="#">3-11</a> and <a href="#">3-15</a>
A26 MID (Microwave Interface Deck for E8247C/57C only)	E8251-60009	<a href="#">3-10</a> and <a href="#">3-14</a>	N/A	
A26 MID (Microwave Interface Deck for E8267C Only)	N/A		E8251-60069	<a href="#">3-11</a> and <a href="#">3-15</a>
A27 40 GHz Doubler (Option 540)	5087-7064	<a href="#">3-10</a> and <a href="#">3-14</a>	N/A	
A27 40 GHz Doubler with High Power (Option 540 and Option 1EA)	5087-7064	<a href="#">3-10</a> and <a href="#">3-14</a>	N/A	
A28 YIG Oscillator	5087-7113	<a href="#">3-16</a> and <a href="#">3-14</a>	5087-7113	<a href="#">3-17</a> and <a href="#">3-15</a>
A29 20 GHz Doubler	5087-7058	<a href="#">3-16</a> and <a href="#">3-14</a>	5087-7058	<a href="#">3-17</a> and <a href="#">3-15</a>
A30 Modulation Filter with High Power	5087-7061	<a href="#">3-16</a> and <a href="#">3-14</a>	5087-7061	<a href="#">3-17</a> and <a href="#">3-15</a>
A31 Motherboard (E8247C/57C only)	E8251-60091	<a href="#">3-16</a>	N/A	
A31 Motherboard (E8267C Only)	N/A		E8251-60201	<a href="#">3-17</a>
A32 10 MHz Crystal Oscillator (Option UNR)	E8251-60071	<a href="#">3-10</a> and <a href="#">3-12</a>	E8251-60071	<a href="#">3-11</a> and <a href="#">3-13</a>
A33 3.5 6dB PAD	N/A		08493-60014	<a href="#">3-11</a> and <a href="#">3-15</a>

**Assemblies and Hardware Options**

Assembly	E8247C E8257C		E8267C Option 520	
A34 Internal Hard Drive	N/A		E8251-60115	3-11 and 3-13
A35 3-20 GHz I/Q Modulator	N/A		5087-7059	3-11
AT1 115 dB Mechanical Attenuator (Option 1E1)	E8251-60070	3-10, 3-16 and 3-14	E8251-60070	3-11, 3-17 and 3-15
B1 Fan	3160-4121	3-10, 3-16 and 3-12	3160-4121	3-11, 3-17 and 3-13
RF Output Connector (2.4mm) (Option 540)	5063-1700	3-55	N/A	
RF Output Connector (3.5 mm) (Option 520)	08673-60040	3-56	08673-60040	3-56
RF Output Connector (Type-N) (Option 520)	08559-60002	3-57	08559-60002	3-57

## Assemblies from the Inside Front Panel View

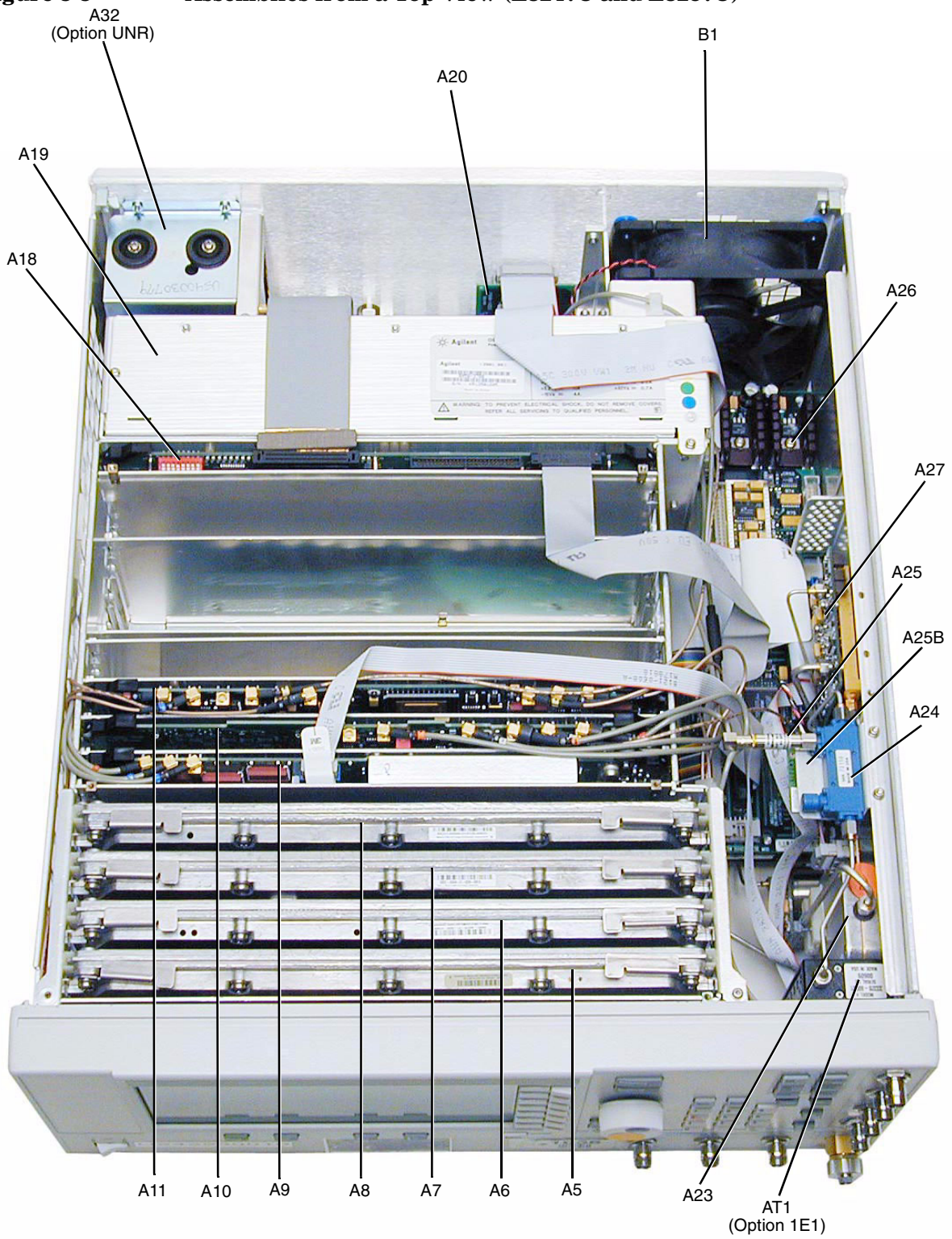
Figure 3-2 Assemblies from the Inside Front Panel View (E8247C, E8257C and E8267C)



se94a

## Assemblies from a Top View

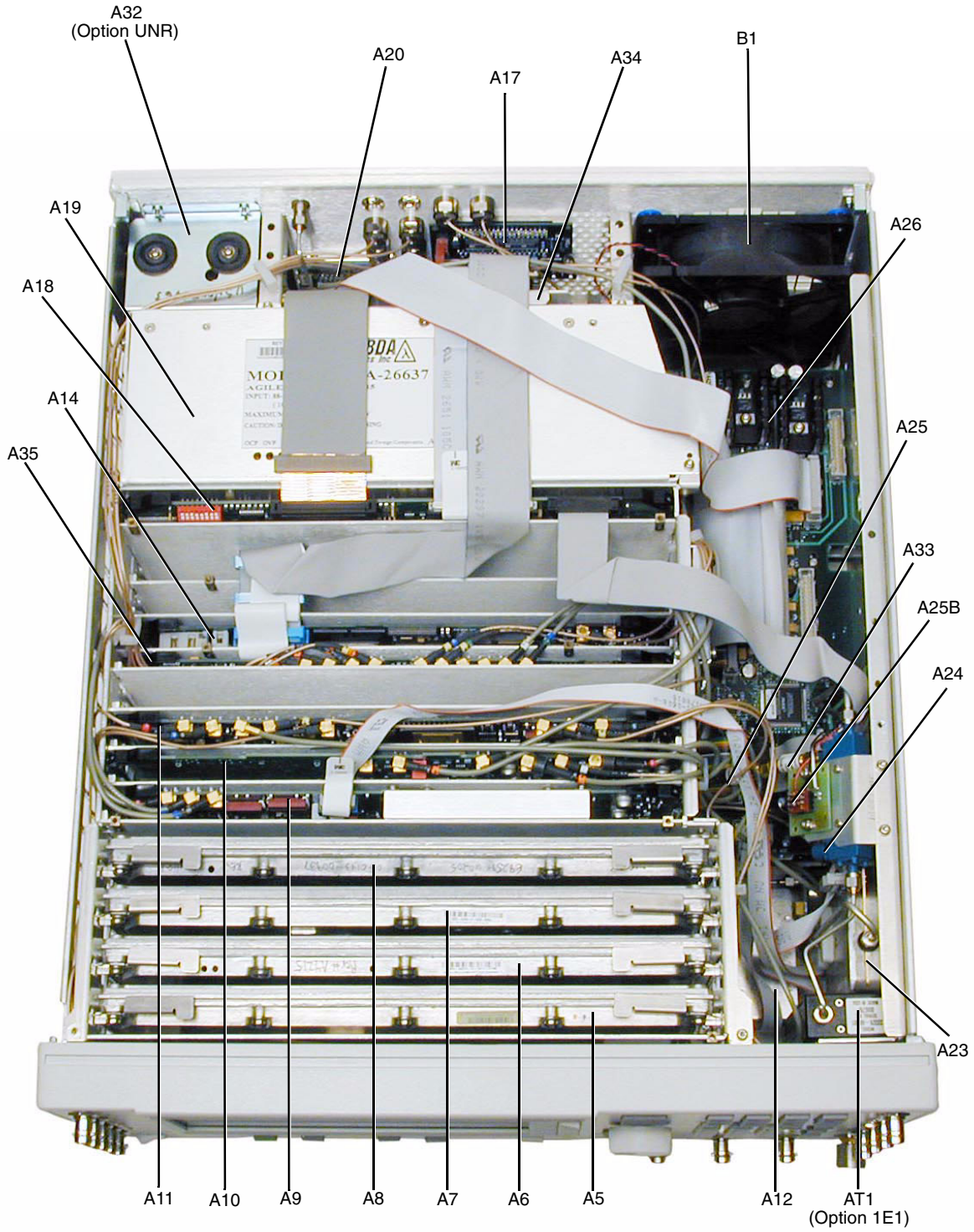
**Figure 3-3** Assemblies from a Top View (E8247C and E8257C)



analog\_top



Figure 3-4 Assemblies from a Top View (E8267C Option 520)

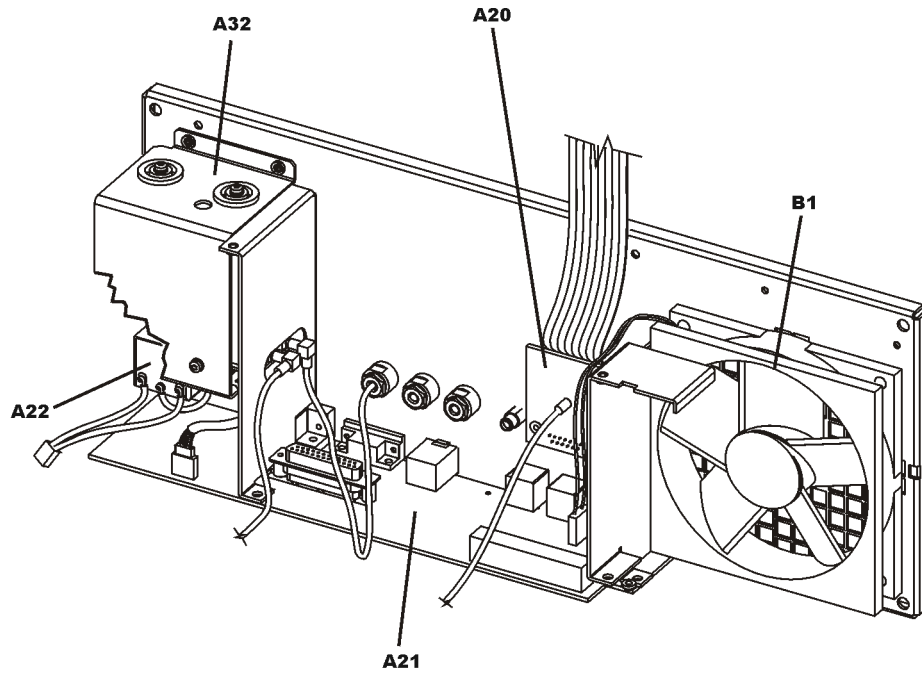


p\_dig\_top



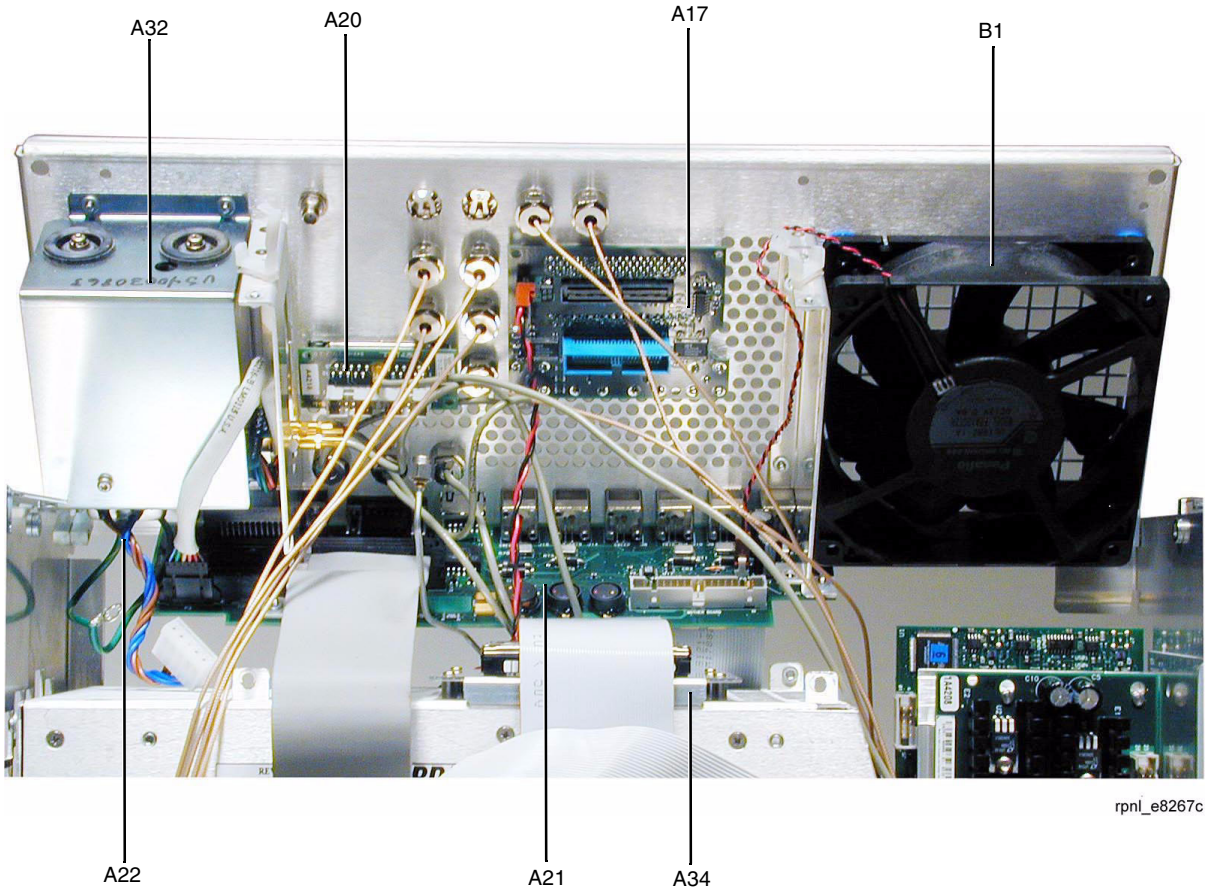
## Assemblies from the Inside Rear Panel View

Figure 3-5 Assemblies from the Inside Rear Panel View (E8247C and E8257C)



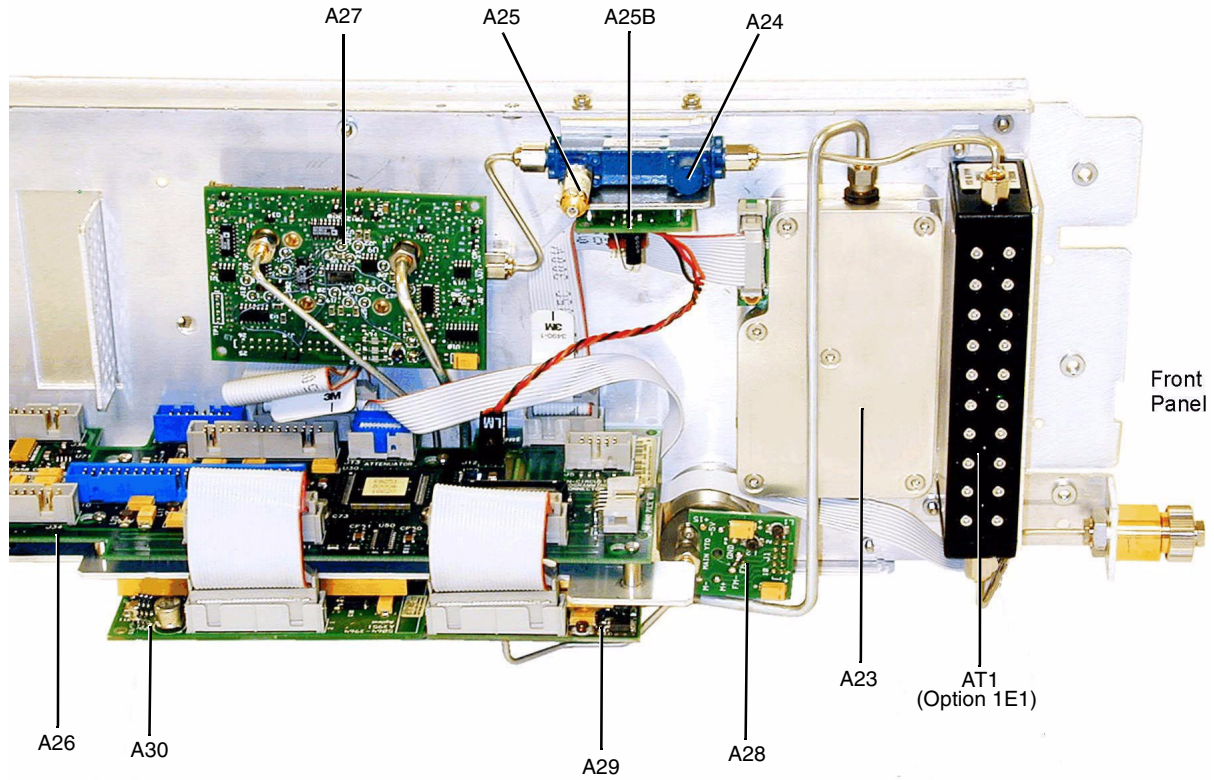
r-pnl\_e8247c&57c

**Figure 3-6** Assemblies from the Inside Rear Panel View (E8267C Option 520)



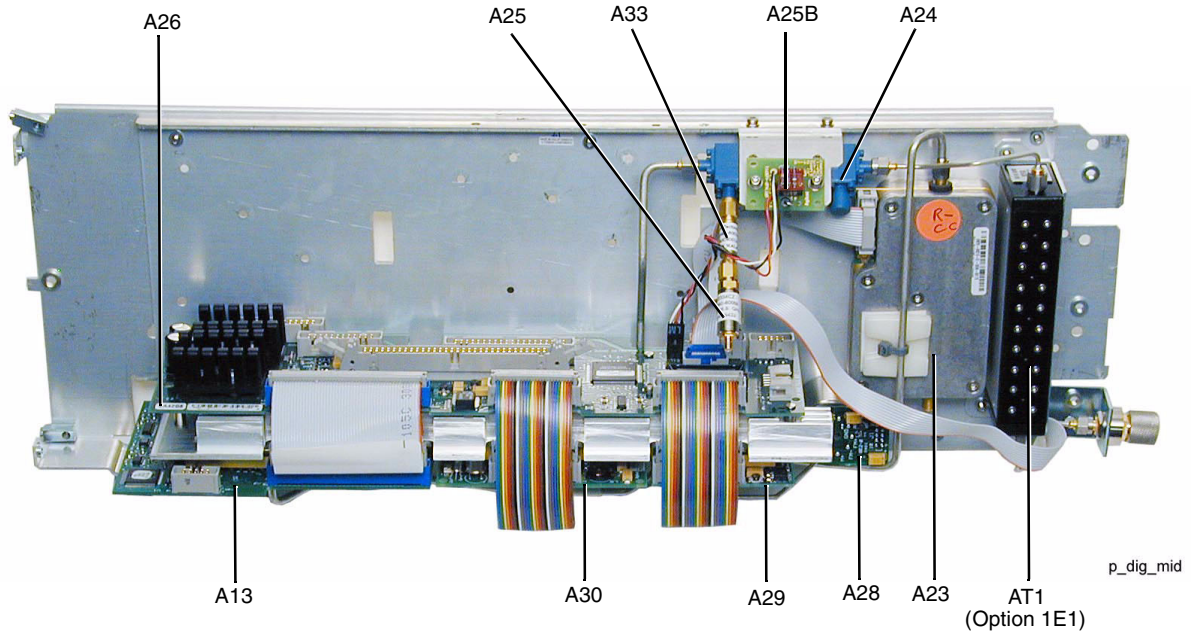
## Assemblies from a Microcircuit Deck View

Figure 3-7 Assemblies from a Microcircuit Deck View (E8247C and E8257C)



analog\_mid

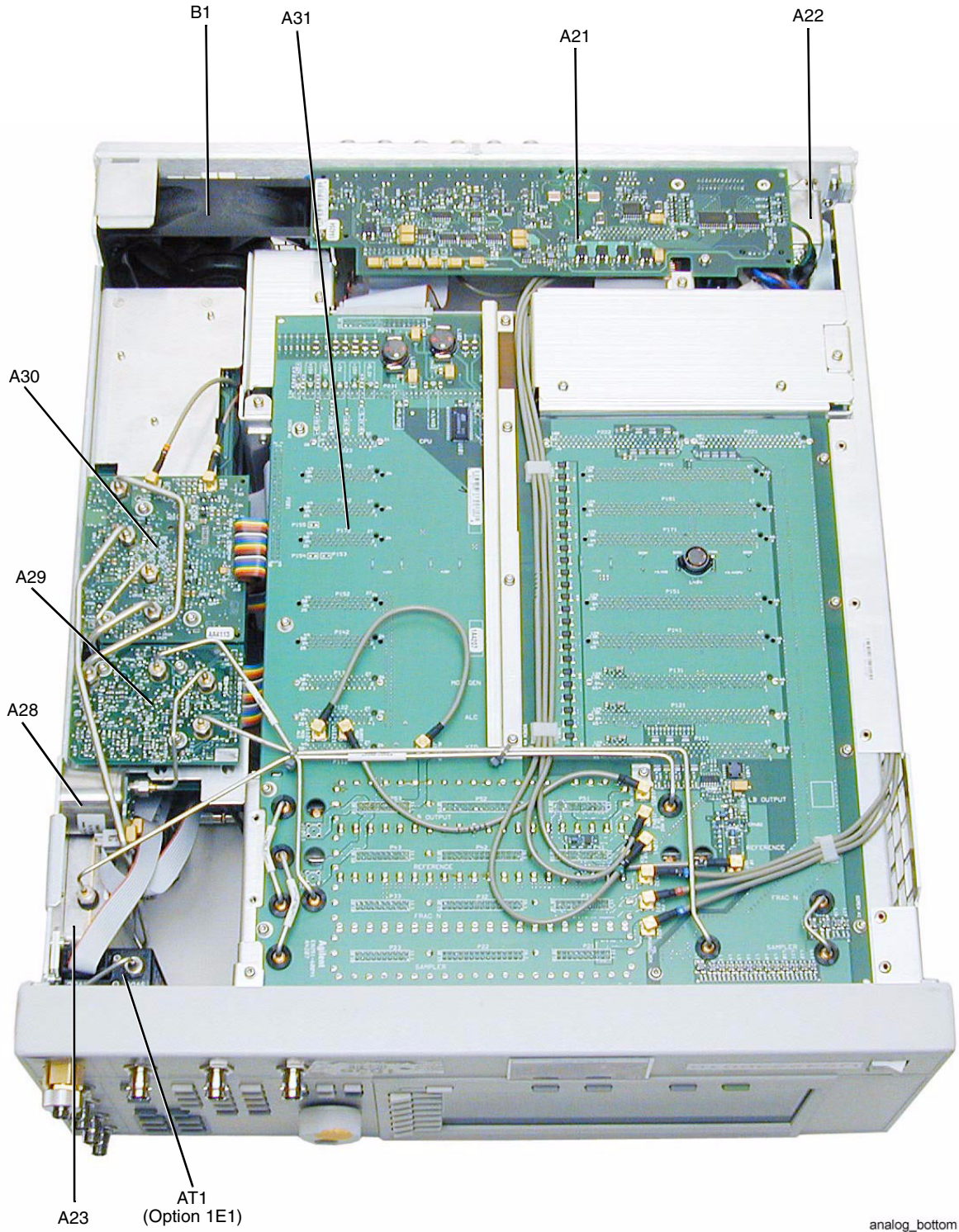
**Figure 3-8** Assemblies from a Microcircuit Deck View (E8267C Option 520)





### Assemblies from a Bottom View

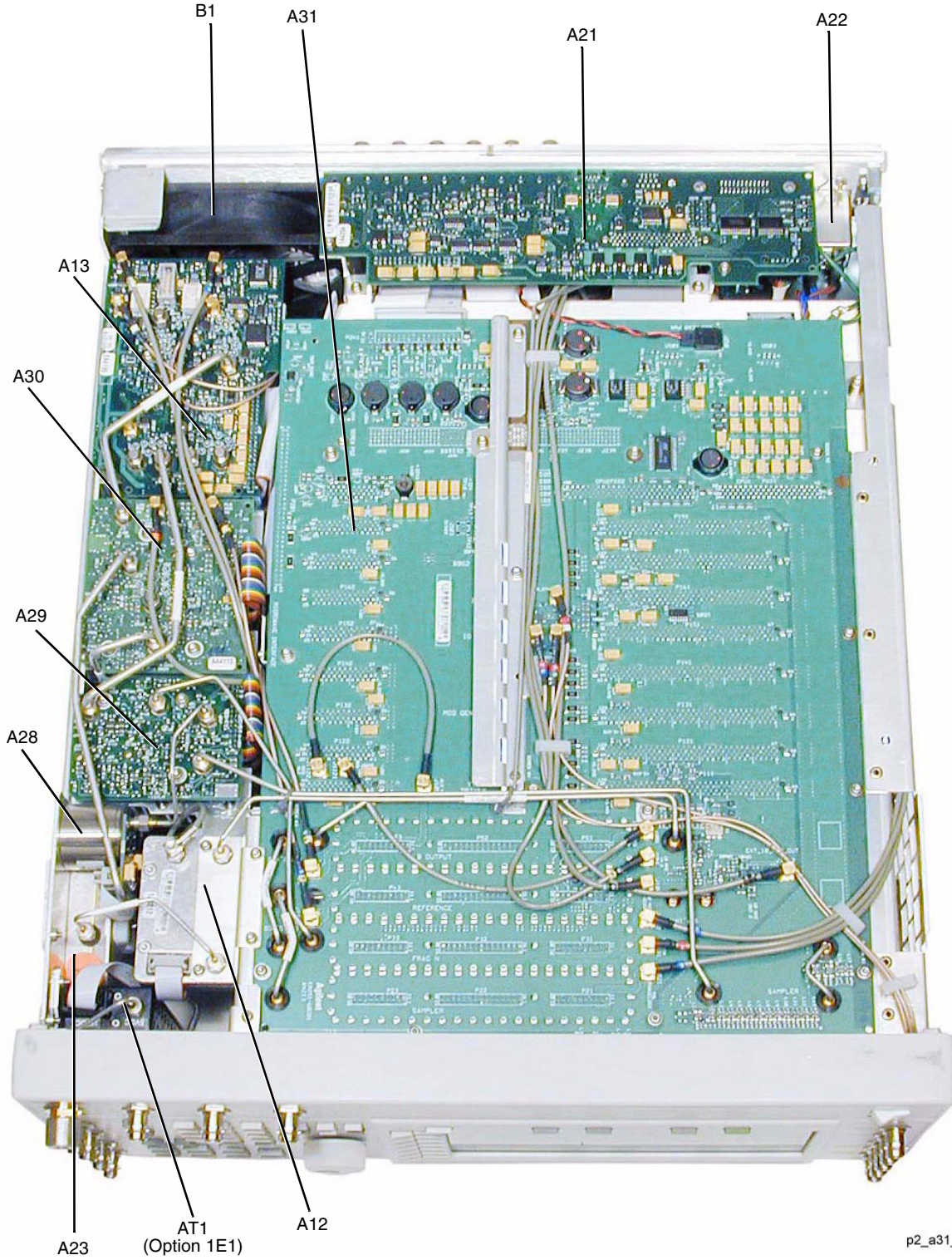
Figure 3-9 Assemblies from a Bottom View (E8247C and E8257C)



analog\_bottom

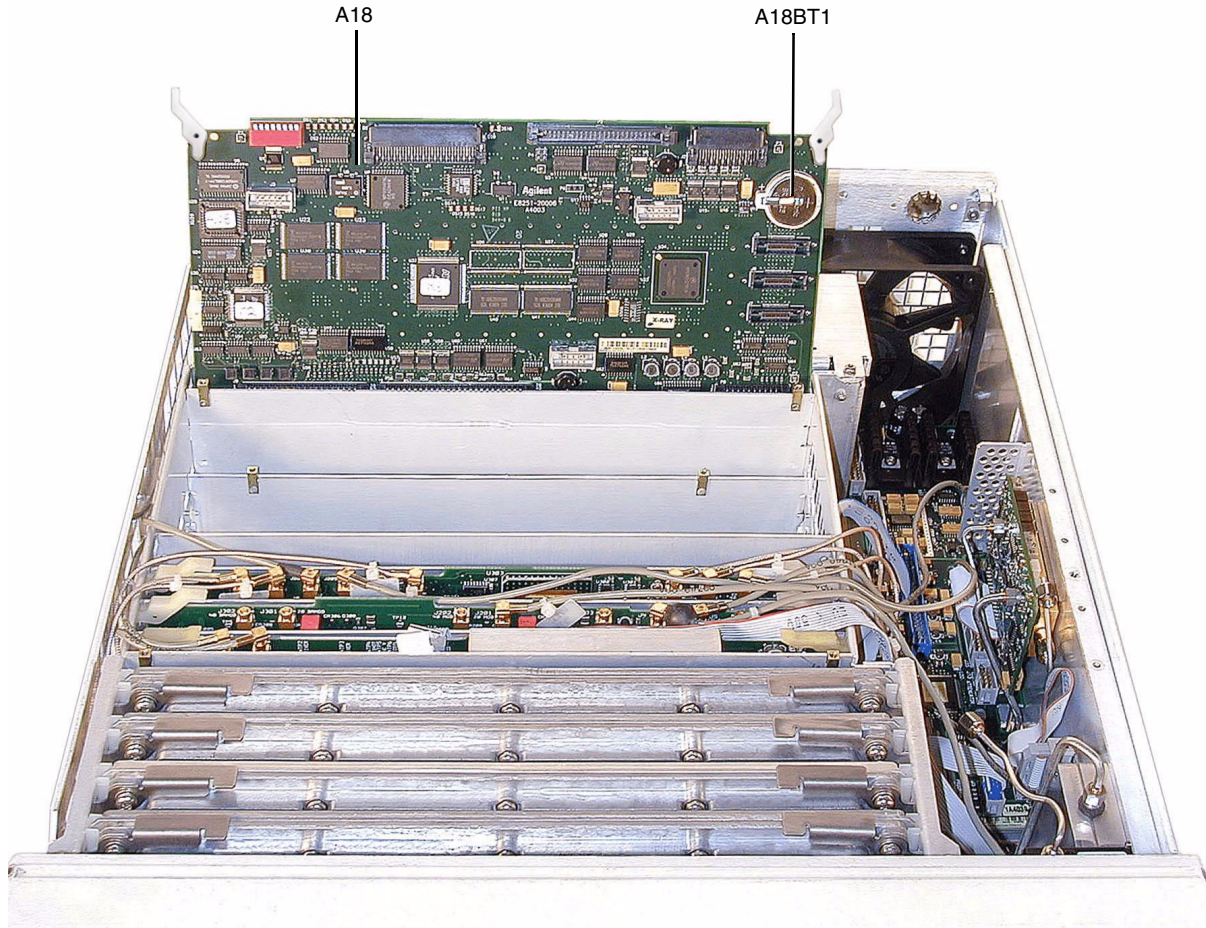


**Figure 3-10** Assemblies from a Bottom View (E8267C Option 520)



## A18BT1 Lithium Battery

Figure 3-11 A18BT1 Lithium Battery



p\_se957a

## **Cables**

This section lists part numbers for the cables in your signal generator.

- “Inside Front Panel” on page 3-26
- “Top View” on page 3-27
- “Rear Panel (Standard)” on page 3-29
- “Rear Panel (Option 1EM)” on page 3-31
- “Microcircuit Deck View” on page 3-32
- “Bottom View” on page 3-34



**Table 3-1 Cables**

<b>Reference Designator</b>	<b>Description</b>	<b>Part Number</b>
A1W1*	Ribbon Cable, A1 Keyboard to P13 of A31 Motherboard	(part of A1)
A2DS1W1*	Wire Cable, A2DS1 to A4 Inverter	(part of A2)
A4W1*	Wire Cable, A4 Inverter to P12 of A31 Motherboard	(part of A4)
A22W1*	A22 Line Module to A19 Power Supply	(part of A22)
A22W2*	A22 Line Module to chassis ground post on rear panel and A19 Power Supply	(part of A22)
A25BW1*	Wire Cable, A25B High Band Detector Bias board to J12 of A26 MID	(part of A25)
A32W1*	Wire Cable, A32 10 MHz Crystal Oscillator to P2 of A21 Rear Panel Interface	(part of A32)
B1W1*	Wire Cable, B1 Fan to P251 of A21 Rear Panel Interface	(part of B1)
W1	Flexible Cable, EXT 1 to J401 of A11 Pulse/Analog Modulation Generator	8121-0628
W2	Flexible Cable, EXT 2 to J402 of A11 Pulse/Analog Modulation Generator	8121-0628
W3	Flexible Cable, LF OUTPUT to J403 of A11 Pulse/Analog Modulation Generator	8121-0628
W4	Flexible Cable, ALC INPUT to J4 of A10 ALC	8121-0859
W5	Flexible Cable, PULSE/TRIGGER GATE INPUT to J201 of A11 Pulse/Analog Modulation Generator	8121-0625
W6	Flexible Cable, PULSE VIDEO OUT to J203 of A11 Pulse/Analog Modulation Generator	8121-0625
W7	Flexible Cable, PULSE SYNC OUT to J202 of A11 Pulse/Analog Modulation Generator	8121-0625
W8	Ribbon Cable, A3 Power Switch (DATA CABLE) to A2 Display	8121-0165
W9	Ribbon Cable, P1 of A3 Power Switch to P11 of A31 Motherboard	8121-0614
W10	Flexible Cable, J3 of A9 YIG Driver to J1031 of A31 Motherboard	8121-0624
W11	Flexible Cable, J4 of A9 YIG Driver to J1021 of A31 Motherboard	8121-0624
W12	Ribbon Cable, J5 of A9 YIG Driver to J1 of A28 YIG Oscillator	8121-0608

**Table 3-1 Cables**

<b>Reference Designator</b>	<b>Description</b>	<b>Part Number</b>
W13	Flexible Cable, J201 of A10 ALC to J6 of A30 Modulation Filter with Standard or High Power	8121-0624
W14	Flexible Cable, J5 of A10 ALC to J104 A23 Lowband Coupler/Detector	8121-0627
W15 (Option 540)	Flexible Cable, J3 of A10 ALC to A25 40 GHz Highband Detector	8121-0607
W16	Flexible Cable, J204 of A11 Pulse/Analog Modulation Generator to A12 Pulse Modulator Board	8121-0623
W17	Flexible Cable, J205 of A11 Pulse/Analog Modulation Generator to J7 of A30 Modulation Filter with Standard or High Power	8121-0626
W18	Ribbon Cable, J1 of A18 CPU to J3 of A21 Rear Panel Interface	8121-0617
W19	Ribbon Cable, J2 of A18 CPU to J30 of A26 MID (Microcircuit Interface Deck)	8121-0619
W20	Ribbon Cable, J1 of A20 SMI (Source Module Interface) to J20 of A26 MID (Microcircuit Interface Deck)	8121-0677
W21	Flexible Cable, J1043 of A31 Motherboard to rear panel (10 MHz OUT)	8121-0622
W22	Flexible Cable, J1042 of A31 Motherboard to rear panel (10 MHz IN)	8121-0622
W23	Ribbon Cable, J2 of A21 Rear Panel Interface to P241 of A31 Motherboard	8121-0611
W24 (Option 540)	Semi-Rigid Cable, A24 40 GHz Highband Coupler output to AT1 115 dB Mechanical Attenuator (Option 1E1)	E8251-20025
W25 (Option 540)	Semi-Rigid Cable, AT1 output to 2.4 mm RF Output adapter Option 1E1	E8251-20028
W26 (Option 540)	Semi-Rigid Cable, A24 40 GHz Highband Coupler to 2.4mm RF Output adapter (models without Option 1E1) not shown	E8251-20035
W27	Semi-Rigid Cable, J2 of A23 Low Band Coupler/Detector to J3 of A30 Modulator Filter with Standard or High Power	E8251-20031
W28	Ribbon Cable, J100 of A23 Low Band Coupler/Detector to J15 of A26 MID	8121-0616
W29 (Option 540)	Ribbon Cable, J10 of A27 40 GHz Doubler to J33 of A26 MID	8121-0613
W30 (Option 540)	Semi-Rigid Cable, J2 of A27 40 GHz Doubler output to A24 High Band Coupler input	E8251-20024

**Table 3-1 Cables**

<b>Reference Designator</b>	<b>Description</b>	<b>Part Number</b>
W31 (Option 540)	Semi-Rigid Cable, J3 of A27 40 GHz Doubler to J2 of A30 Modulator Filter with Standard or High Power	E8251-20023
W32 (Option 540)	Semi-Rigid Cable, J1 of A27 40 GHz Doubler to J4 of A30 Modulator Filter with Standard or High Power	E8251-20022
W33	Ribbon Cable, J32 of A26 MID to J10 of A29 20 GHz Doubler	8121-0613
W34	Ribbon Cable, J31 of A26 MID to J10 of A30 Modulator Filter with Standard or High Power	8121-0613
W35	Ribbon Cable, J10 of A26 MID to P201 of A31 Motherboard	8121-0615
W36	Ribbon Cable, AT1 115 dB Mechanical Attenuator to J13 of A26 MID (Microcircuit Interface Deck)	8121-0982
W37 (E8247C/57C)	Semi-Rigid Cable, A23 Lowband Coupler/Detector to A31 Motherboard (Output)	E8251-20225
W38	Semi-Rigid Cable, A28 YIG Oscillator out to J1 of A29 20 GHz Doubler	E8251-20014
W39	Semi-Rigid Cable, J4 of A29 20 GHz Doubler to A31 Motherboard (Sampler)	E8251-20015
W40	Semi-Rigid Cable, J3 of A29 20 GHz Doubler to A31 Motherboard (Frac-N)	E8251-20224
W41 (E8247C/57C)	Semi-Rigid Cable, J2 of A29 20 GHz Doubler to J1 of A30 Modulation Filter	E8251-20017
W42	Semi-Rigid Cable, A31 Motherboard (Sampler) to Motherboard (Reference)	E8251-20226
W43	Semi-Rigid Cable, A31 Motherboard (Frac-N) to A31 Motherboard (Output)	E8251-20226
W44	Flexible Cable, J1051 of A31 Motherboard to J1122 of A31 Motherboard	8121-0620
W45	Flexible Cable, J1055 of A31 Motherboard to J1121 of A31 Motherboard	8121-0620
W46	Semi-Rigid Cable, A31 Motherboard (Sampler) to A31 Motherboard (Frac-N)	E8251-20029
W47	Flexible Cable, J1 of A32 10 MHz Crystal Oscillator to J1041 of A31 Motherboard	8121-0621
W48	Flexible Cable, J2 of A32 10 MHz Crystal Oscillator to rear panel (10 MHz EFC)	8121-6839
W49 (E8267C)	Flexible Cable, I IN to J7 of A35 3-20 GHz I/Q Modulator	8121-0901

**Table 3-1 Cables**

<b>Reference Designator</b>	<b>Description</b>	<b>Part Number</b>
W50 (E8267C)	Flexible Cable, Q IN to J8 of A35 3-20 GHz I/Q Modulator	8121-0901
W51 (E8267C)	Flexible Cable, DATA to J500 of A31 Motherboard	8121-0628
W52 (E8267C)	Flexible Cable, DATA CLOCK to J501 of A31 Motherboard	8121-0628
W53 (E8267C)	Flexible Cable, SYMBOL SYNC to J502 of A31 Motherboard	8121-0628
W54	Flexible Cable, J9 of A9 YIG Driver to J1032 of A31 Motherboard	8121-0624
W55	Flexible Cable, J303 of A10 ALC to rear panel (SOURCE MOD INTERFACE)	8121-0636
W56 (E8267C)	Flexible Cable, J14 of A35 3-20 GHz I/Q Modulator to rear panel (-Q OUT)	8121-0901
W57 (E8267C)	Flexible Cable, J13 of A35 3-20 GHz I/Q Modulator to rear panel (-I OUT)	8121-0901
W58 (E8267C)	Flexible Cable, J12 of A35 3-20 GHz I/Q Modulator to rear panel (Q OUT)	8121-0901
W59 (E8267C)	Flexible Cable, J11 of A35 3-20 GHz I/Q Modulator to rear panel (I OUT)	8121-0901
W60 (E8267C)	Flexible Cable, J10 of A35 3-20 GHz I/Q Modulator to J1052 of A31 Motherboard	8121-0626
W61 (E8267C)	Flexible Cable, J9 of A35 3-20 GHz I/Q Modulator to J1053 of A31 Motherboard	8121-0626
W62 (E8267C)	Flexible Cable, J6 of A35 3-20 GHz I/Q Modulator to J7 of A13 I/Q MUX	8121-0624
W63 (E8267C)	Flexible Cable, J5 of A35 3-20 GHz I/Q Modulator to J6 of A13 I/Q MUX	8121-0624
W64 (E8267C)	Ribbon Cable, J13 of A14 Baseband Generator to P2 of A17 Baseband Generator Interface	8121-0920
W65 (E8267C)	Flexible Cable, J800 of A14 Baseband Generator to rear panel (BASEBAND GEN REF IN)	8121-0901
W66 (E8267C)	Ribbon Cable, P2 of A18 CPU to A34 Internal Hard Drive	8121-0685
W67 (E8267C)	Semi-Rigid Cable, A31 Motherboard to rear panel (.25-3.5 GHz COH CARRIER)	E8251-20223

**Table 3-1 Cables**

<b>Reference Designator</b>	<b>Description</b>	<b>Part Number</b>
W68 (E8267C)	Wire Cable, A17 Baseband Generator Interface to J250 of A31 Motherboard	PNR#814157
W69	Ribbon Cable, J14 of A26 MID (Microcircuit Interface Deck) to A12 Pulse Modulator Board	8121-0912
W70 (E8267C)	Ribbon Cable, J34 of A26 MID (Microcircuit Interface Deck) to A13 I/Q MUX	8121-0615
W71 (Option 1EM)	Semi-Rigid Cable, A24 20 GHz Highband Coupler IN to J2 of A30 Modulation Filter with Standard or High Power	E8251-20093
W72 (Option 1EM)	Semi-Rigid Cable, A24 20 GHz Highband Coupler output to AT1 115 dB Mechanical Attenuator (Option 1E1) input	E8251-20094
W73 (Option 1EM)	Semi-Rigid Cable, AT1 115 dB Mechanical Attenuator to 3.5mm or Type-N RF Output adapter (RF OUT)	E8251-20095
W74 (Option 520)	Semi-Rigid Cable, A24 20 GHz Highband Coupler IN to J2 of A30 Modulation Filter with Standard or High Power	E8251-20227
W75	Semi-Rigid Cable, A23 Lowband Coupler/Detector to A12 Pulse Modulator Board	E8251-20033
W76	Semi-Rigid Cable, A12 Pulse Modulator Board to A31 Motherboard (Output)	E8251-20032
W77 (E8267C)	Semi-Rigid Cable, J2 of A29 20 GHz Doubler to A13 I/Q MUX	E8251-20018
W78 (E8267C)	Semi-Rigid Cable, J1 of A30 Modulation Filter with Standard or High Power to A13 I/Q MUX	E8251-20019
W79 (E8267C)	Flexible Cable, J107 of A13 I/Q MUX to rear panel (WIDEBAND Q INPUT)	8121-0628
W80 (E8267C)	Flexible Cable, J106 of A13 I/Q MUX to rear panel (WIDEBAND I INPUT)	8121-0628
W81 (Option 520)	Flexible Cable, J3 of A10 ALC to A25 20 GHz Highband Detector	8121-0900
W82 (Option 520)	Flexible Cable, J3 of A10 ALC to A25 20 GHz Highband Detector	8121-0900
W83 (Option 1EM)	Semi-Rigid Cable, J2 of A27 40 GHz Doubler output to A24 High Band Coupler input	E8251-20070
W84 (Option 1EM)	Semi-Rigid Cable, A24 40 GHz Highband Coupler output to AT1 115 dB Mechanical Attenuator (Option 1E1) input	E8251-20071
W85 (Option 1EM)	Semi-Rigid Cable, AT1 115 dB Mechanical Attenuator to 2.4mm RF Output adapter (RF OUT)	E8251-20072

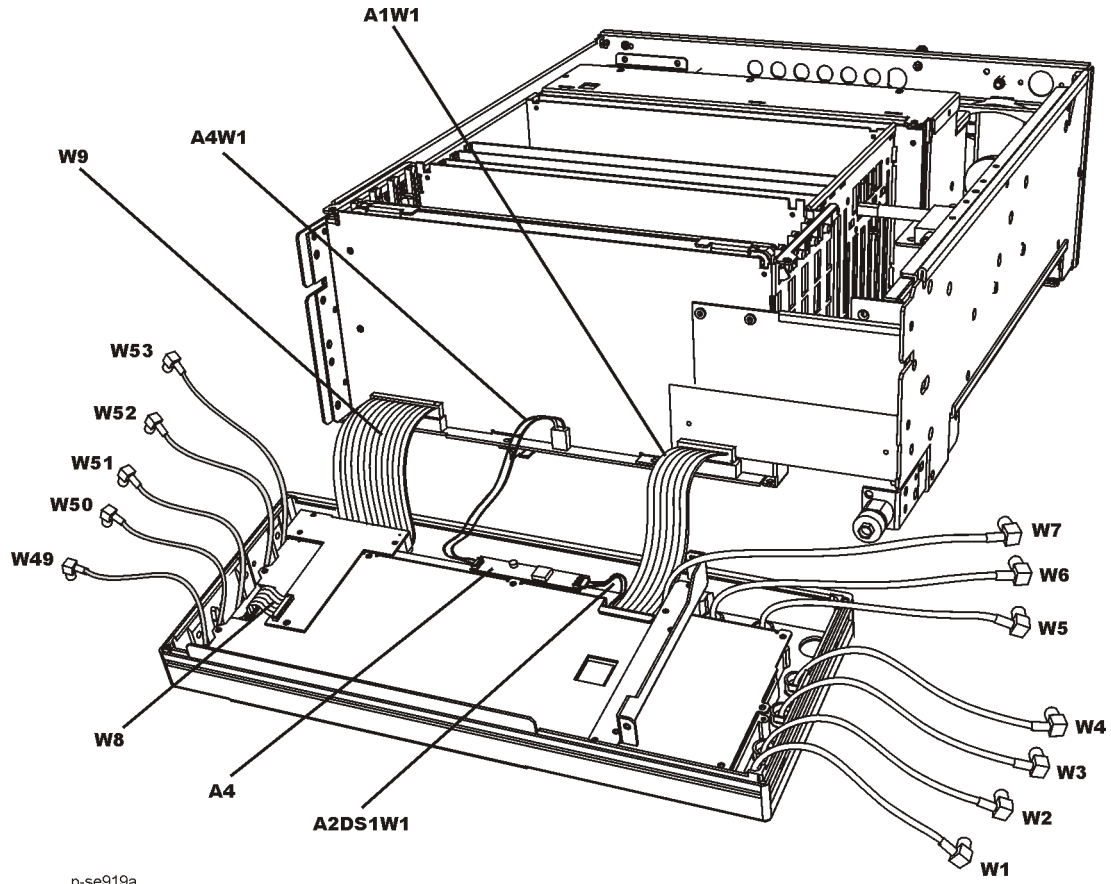
**Table 3-1 Cables**

<b>Reference Designator</b>	<b>Description</b>	<b>Part Number</b>
W86 (Option 520)	Semi-Rigid Cable, AT1 output to 3.5 mm or Type-N RF Output adapter	E8251-20027
W87 (Option 1EM) (Option 540)	Semi-Rigid, A24 40 GHz Highband Coupler in to RF Output adapter (models without Option 1E1) not shown	E8251-20092
W88 (Option 1EM) (Option 520)	Semi-Rigid, A24 20 GHz Highband Coupler in to RF Output adapter (models without Option 1E1) not shown	E8251-20096
W89 (Option 520)	Semi-Rigid Cable, A24 20 GHz Highband Coupler to 3.5mm RF Output adapter (models without Option 1E1) not shown	E8251-20034

\*. This cable is not replaceable by itself. You must order the corresponding assembly.

## Inside Front Panel

Figure 3-12 Inside Front Panel



p-se919a



## Top View

Figure 3-13 Top View (E8247C and E8257C)

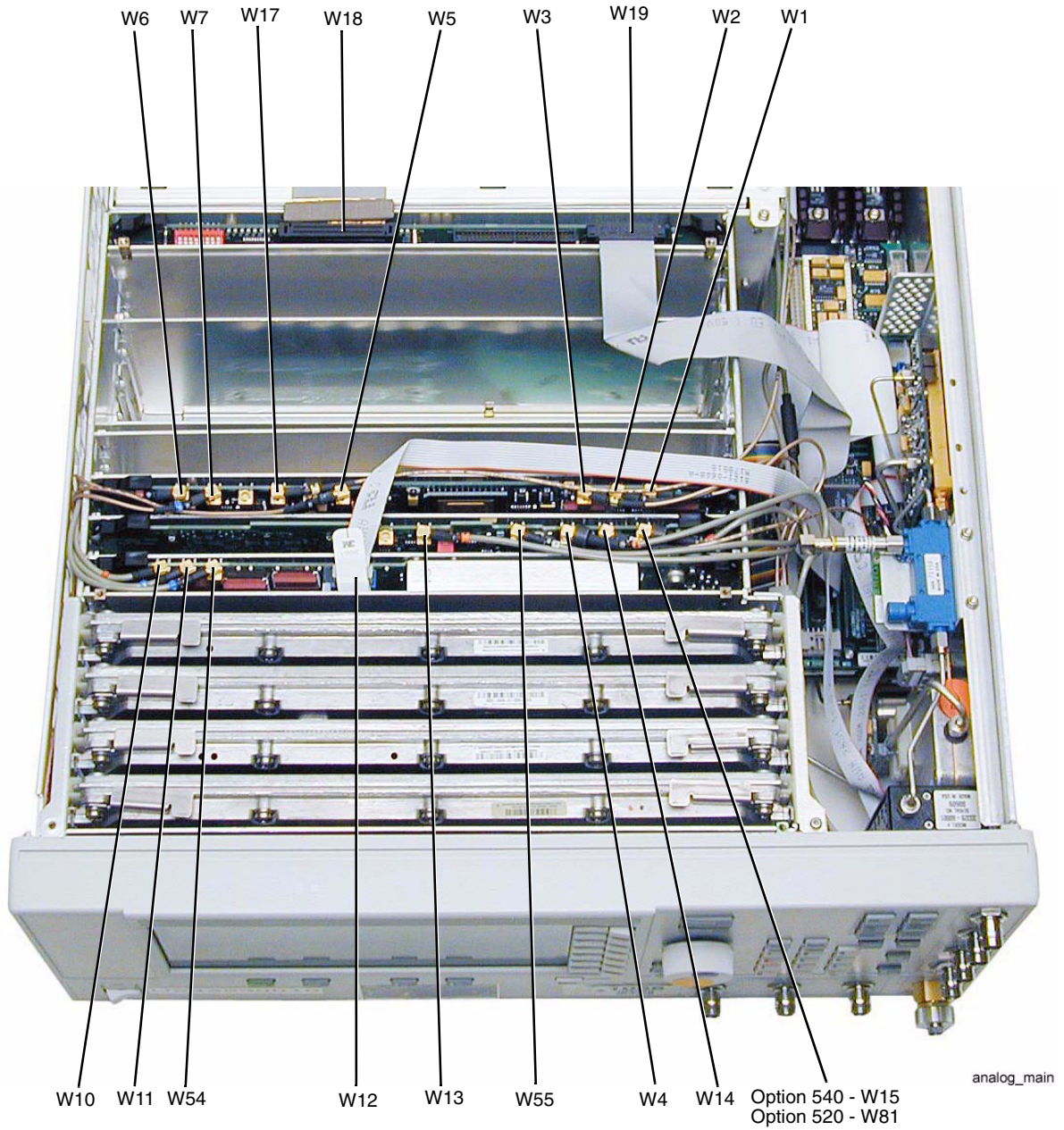
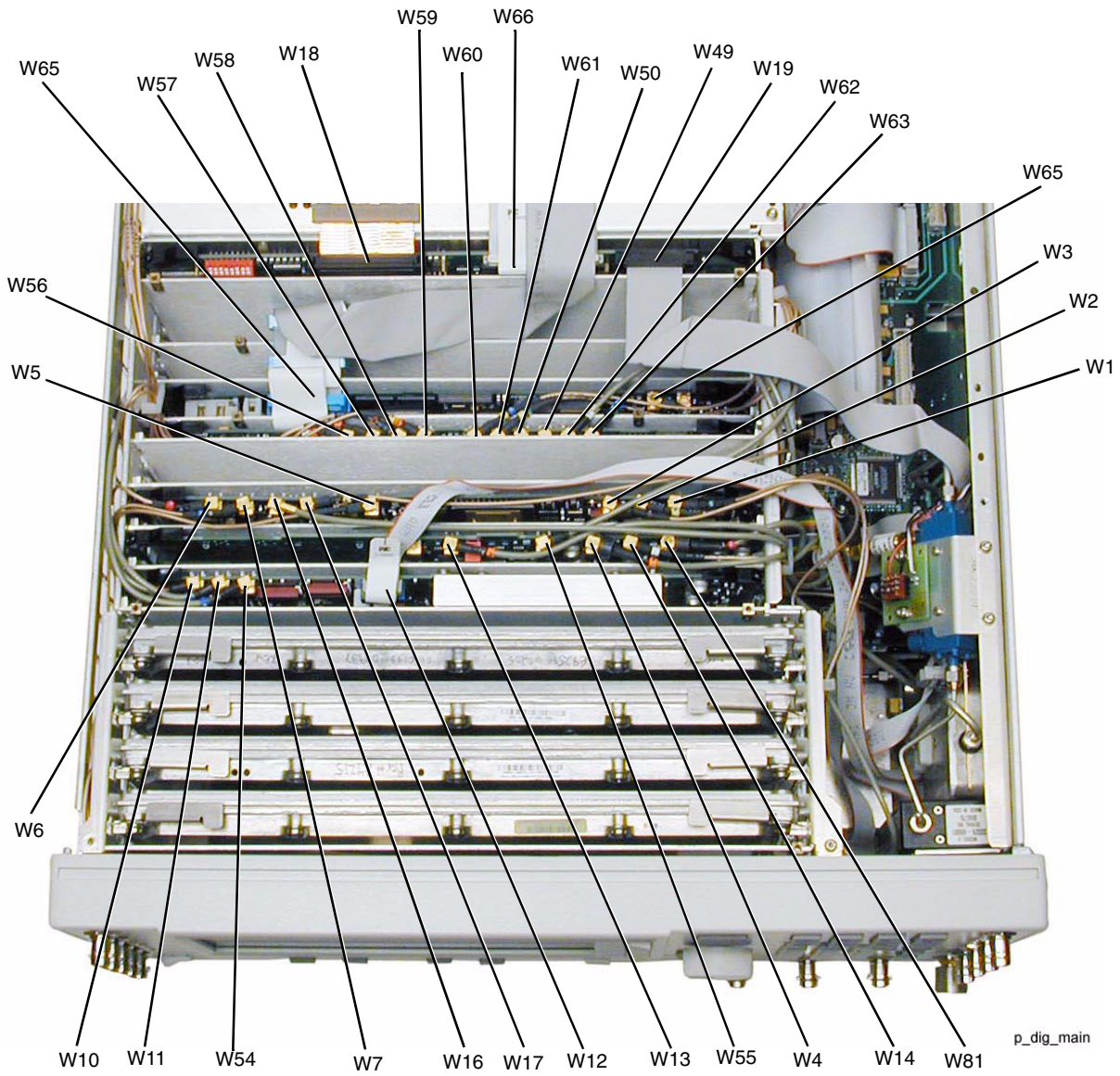


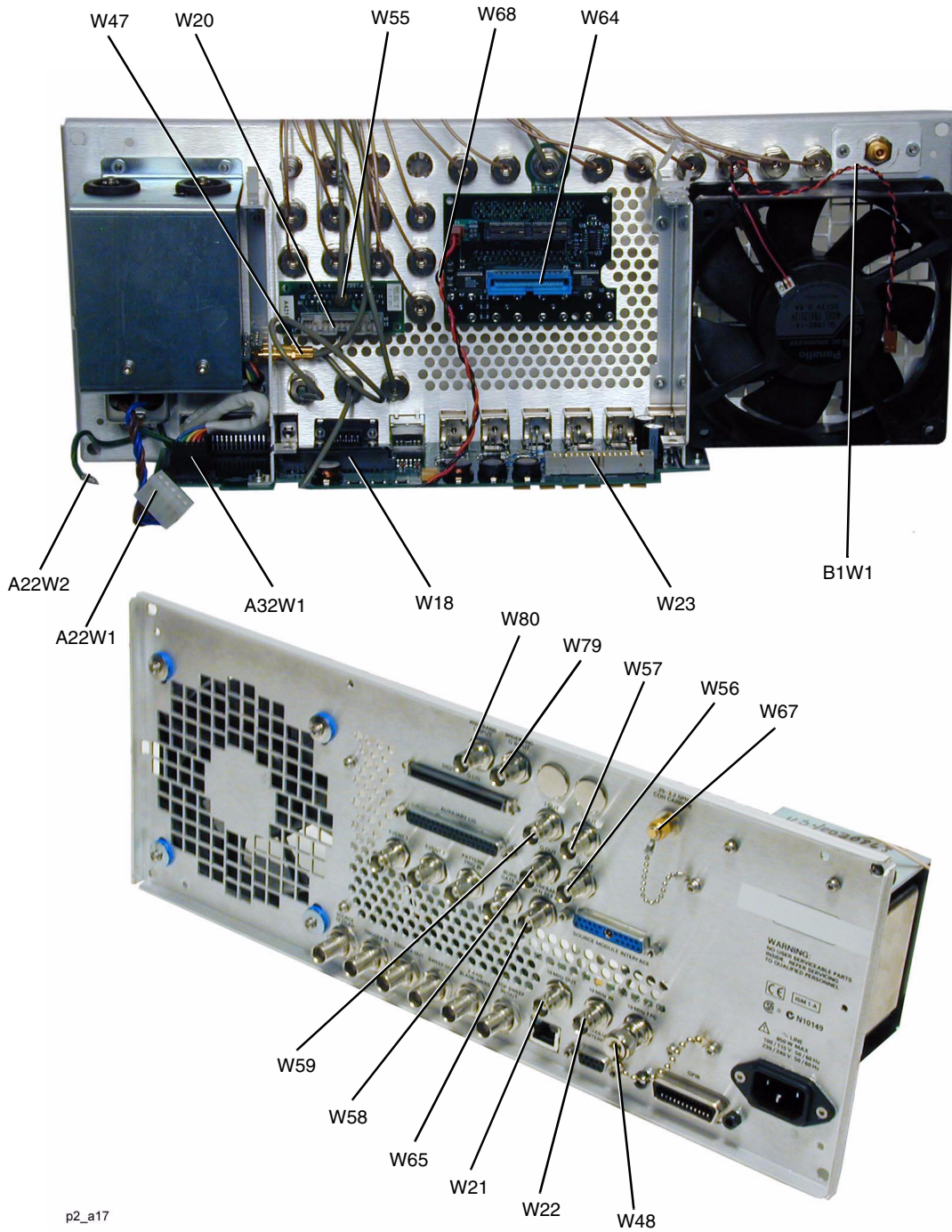
Figure 3-14 Top View (E8267C)





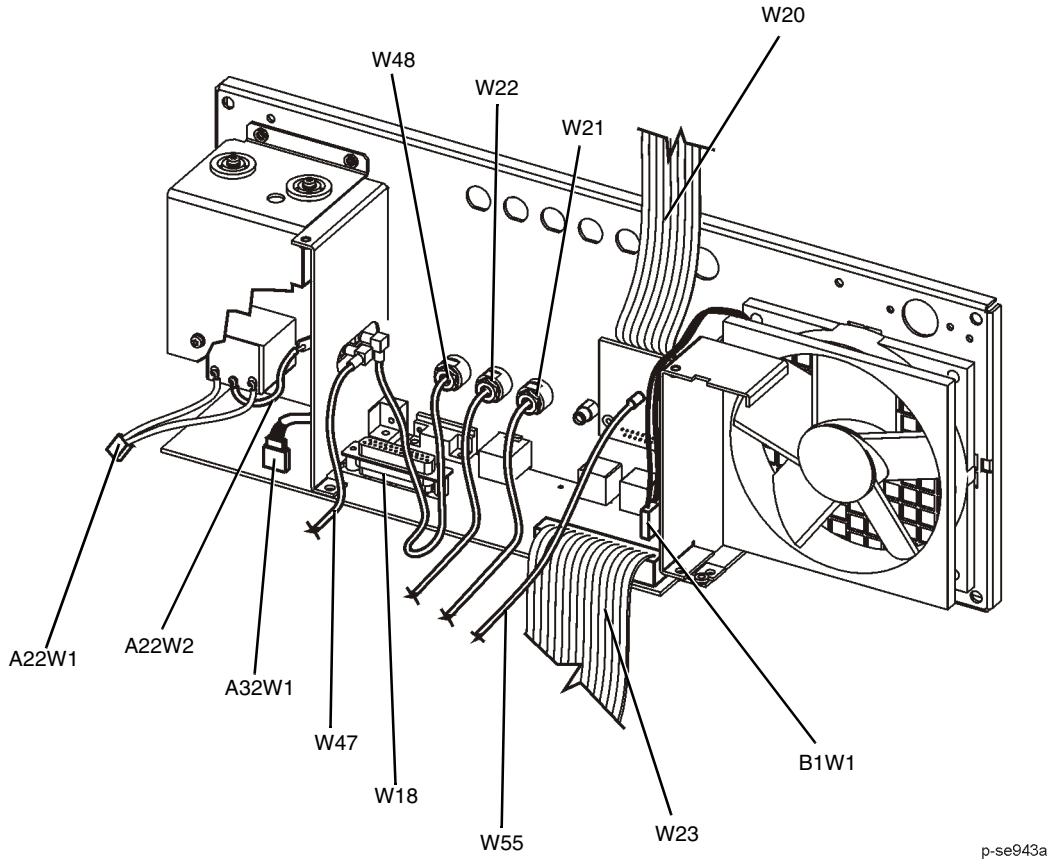
## Rear Panel (Standard)

Figure 3-15 Rear Panel - Standard (E8267C)



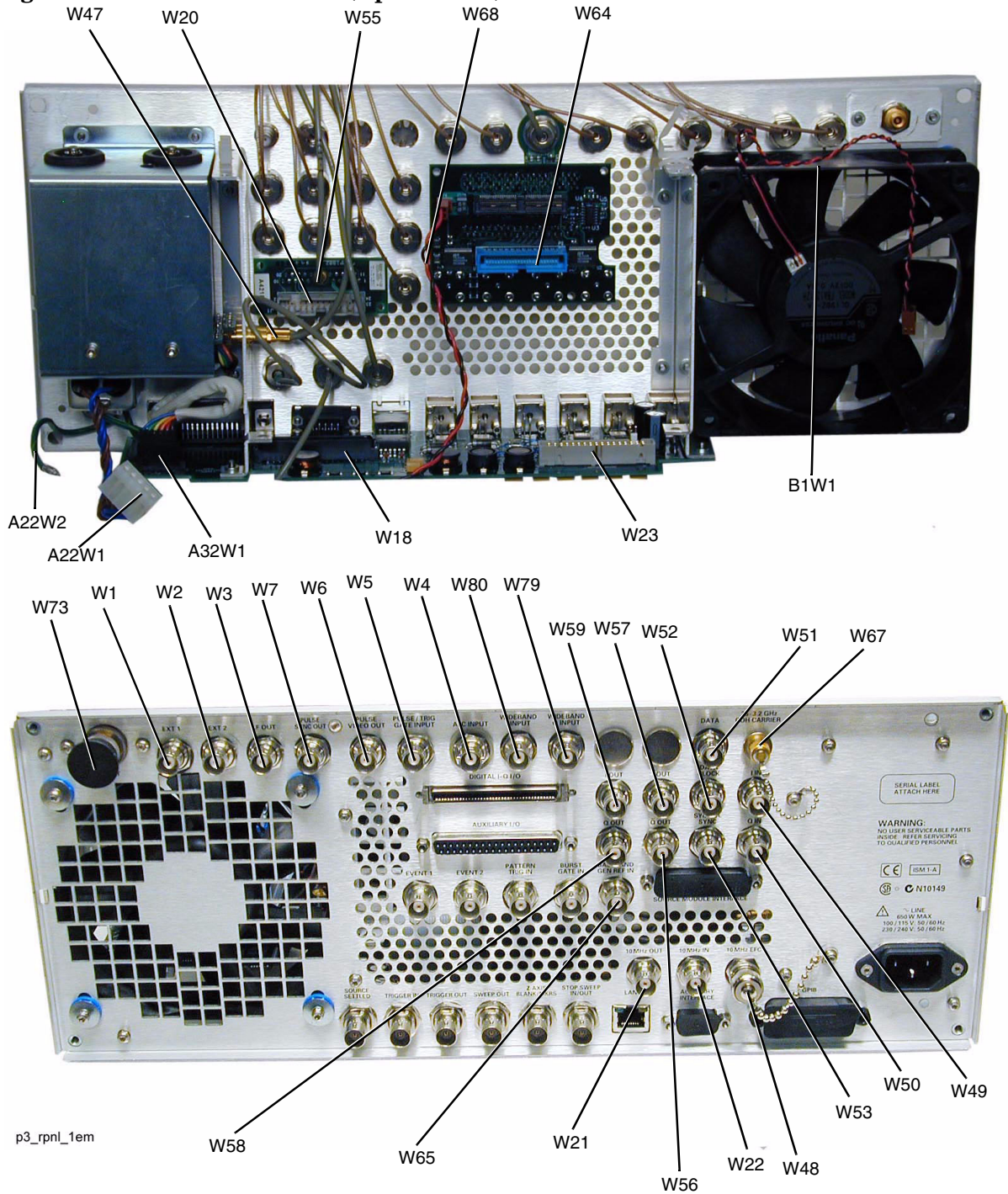
p2\_a17

**Figure 3-16 Rear Panel - Standard (E8247C and E8257C)**



### Rear Panel (Option 1EM)

Figure 3-17 Rear Panel (Option 1EM)

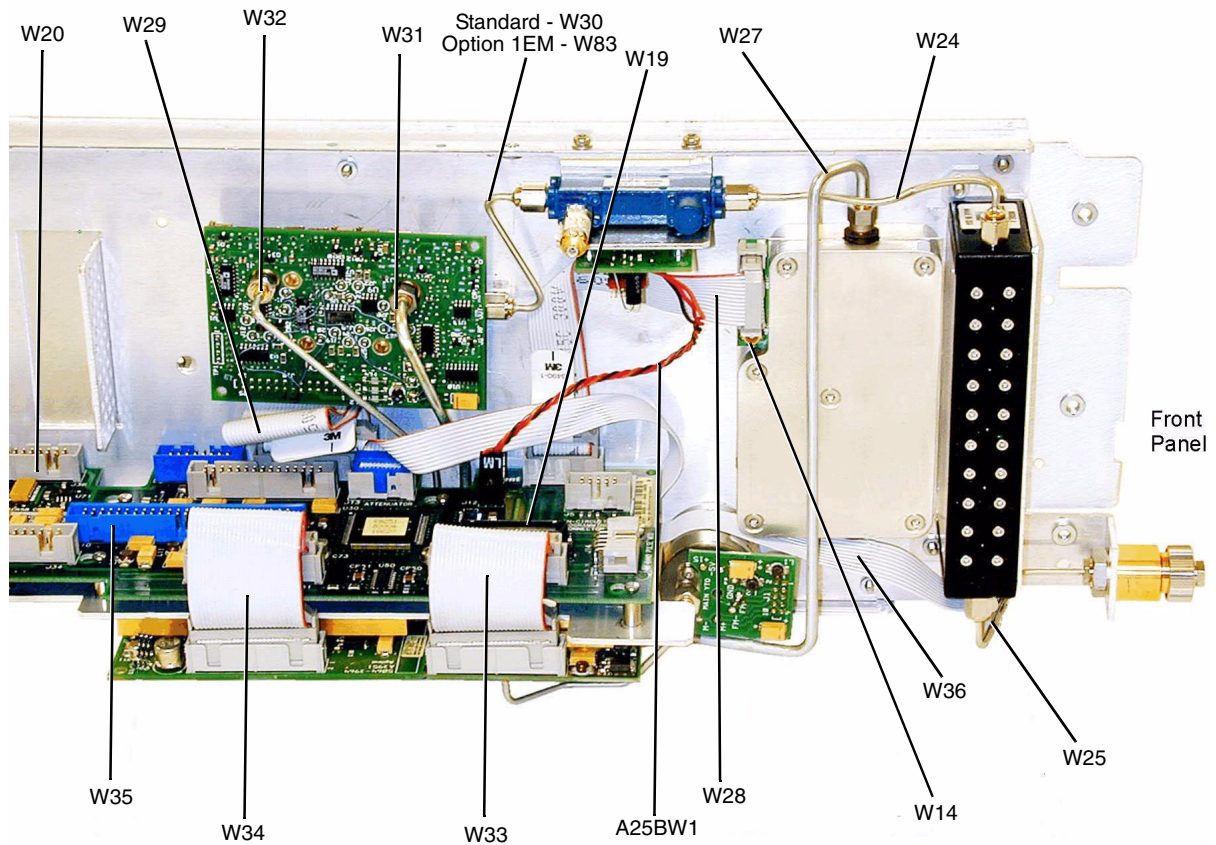


p3\_rpn1\_1em



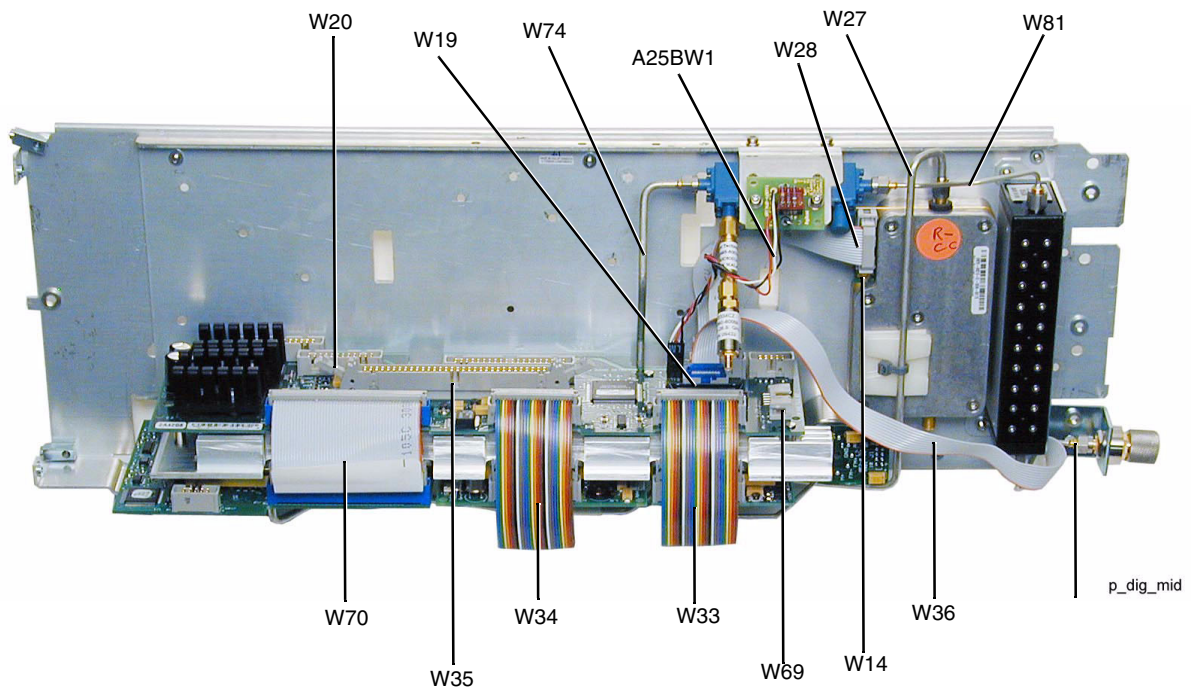
### Microcircuit Deck View

Figure 3-18 E8247C and E8257C (Option 540) MID

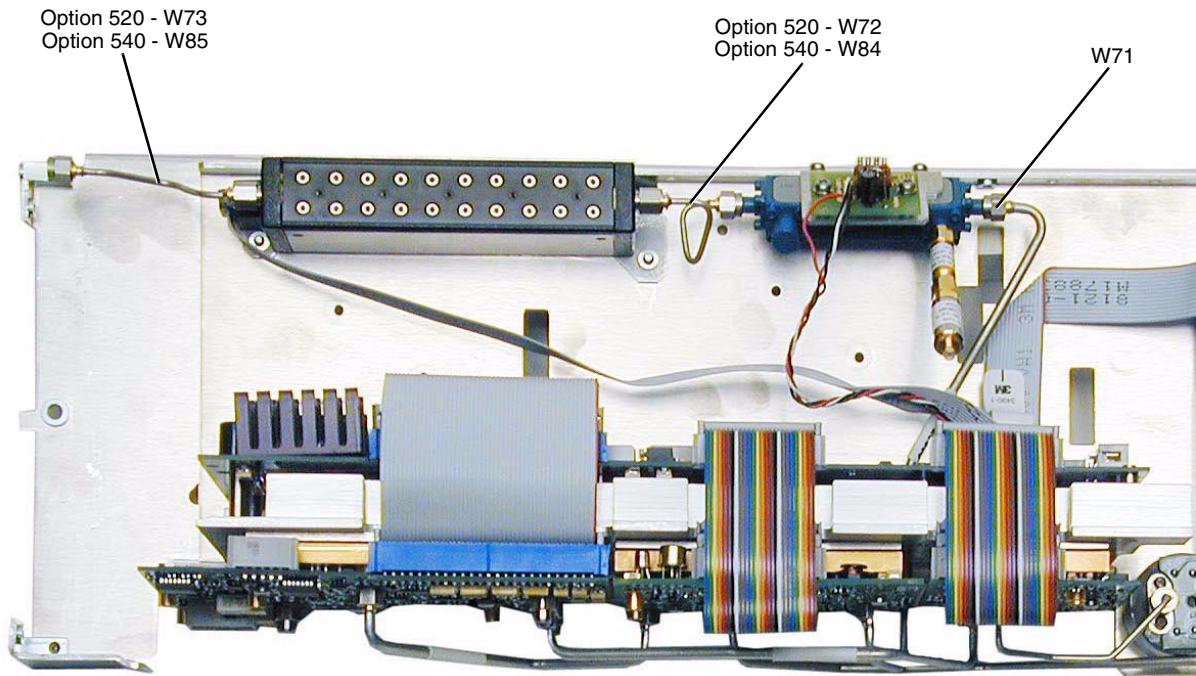


analog\_mid

**Figure 3-19 E8267C MID**



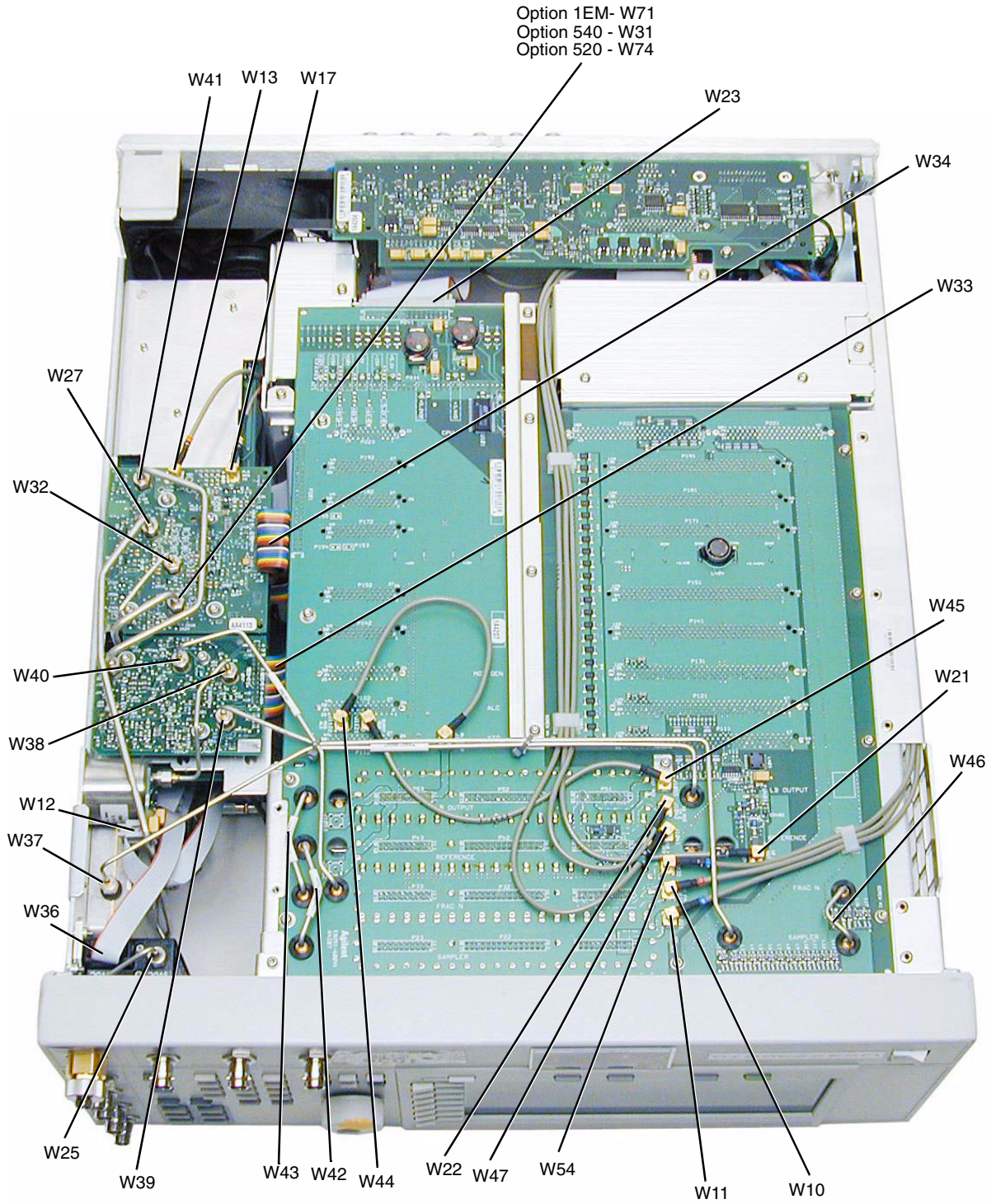
**Figure 3-20 MID (Option 1EM Cables only)**





## Bottom View

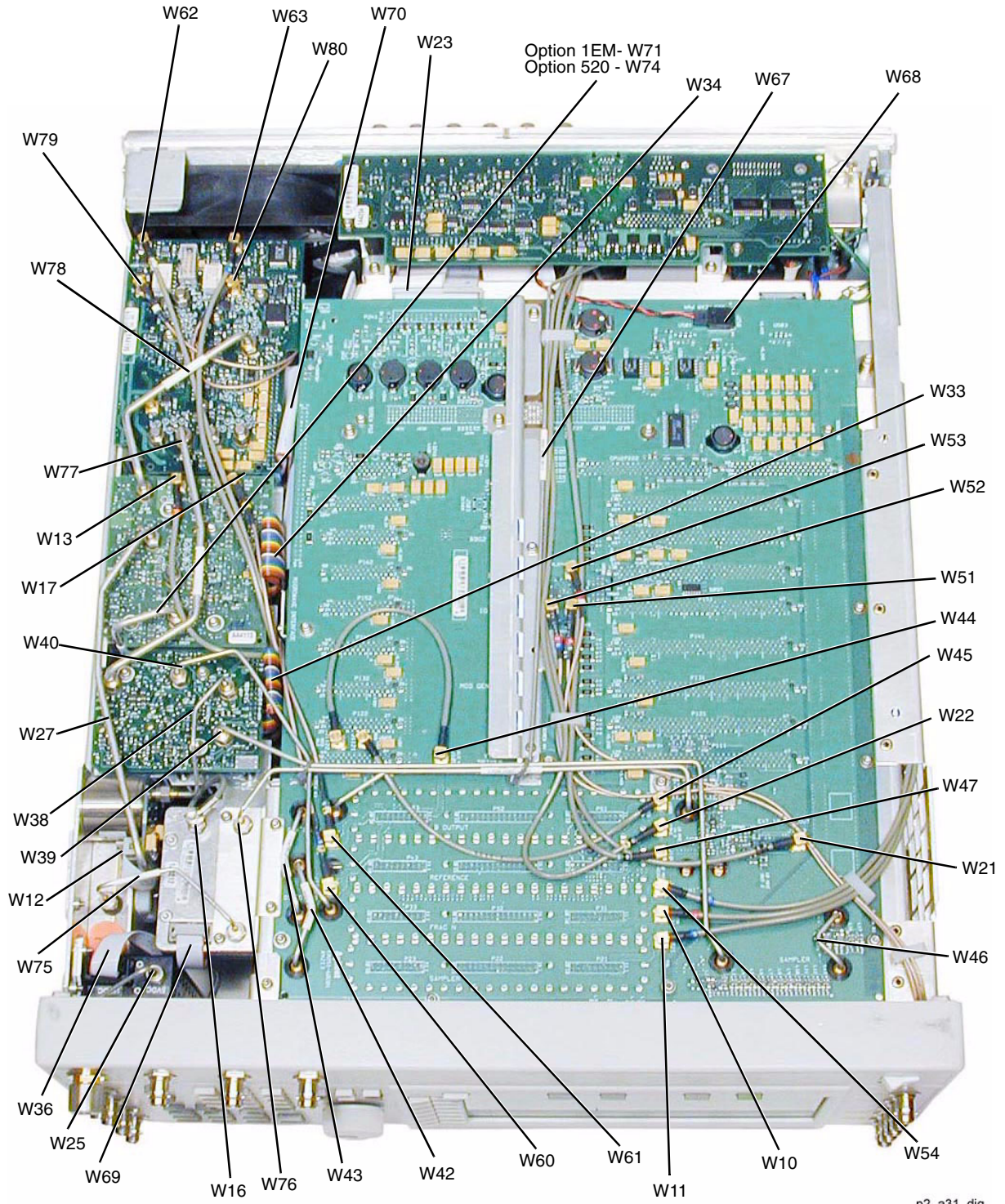
Figure 3-21 Bottom View (E8247C/57C)



analog\_bottom



**Figure 3-22**      **Bottom View (E8267C)**



p2\_a31\_dig

*This page intentionally left blank*

## Hardware

This section lists part numbers for hardware and other instrument parts in your signal generator.

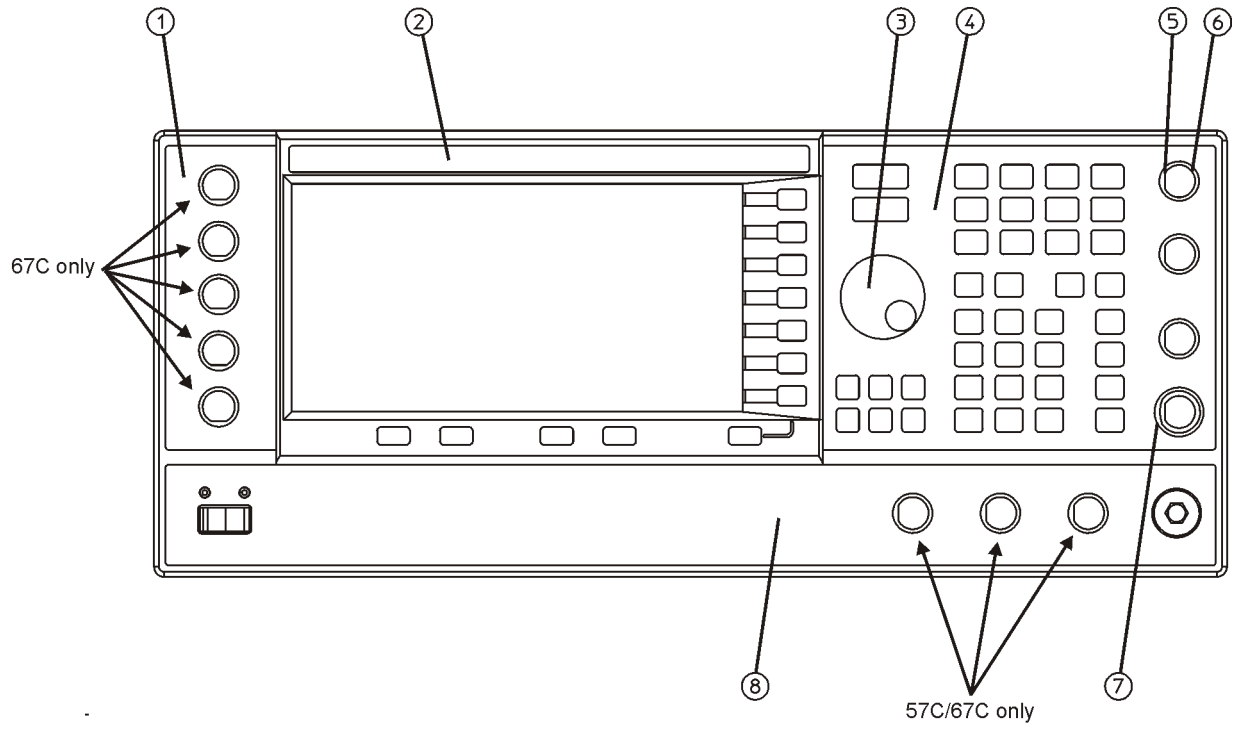
- “Front Panel View” on page 3-38
- “Disassembled Front Panel View” on page 3-40
- “Disassembled Rear Panel View” on page 3-42
- “Disassembled A32 10 MHz Crystal Oscillator (Option UNR)” on page 3-45
- “Disassembled Rear Panel View” on page 3-42
- “Disassembled AT1 115 dB Attenuator View (Option 1E1)” on page 3-47
- “Disassembled A24 20 GHz High Band Coupler and A25B Highband Detector Bias Board” on page 3-48
- “Disassembled A24 40GHz High Band Coupler and A25B High Band Detector Bias Board” on page 3-49
- “Microcircuit Interface Deck Top View” on page 3-50
- “Main Chassis and MID Bottom View” on page 3-52
- “2.4 mm RF Output Connector (Option 540 Only)” on page 3-55
- “APC 3.5 RF Output Connector (Option 520 Only)” on page 3-56
- “Type-N RF Output Connector (Option 1ED Models Only)” on page 3-57
- “Main Chassis with Inside Cover and Right-Side Support Wall” on page 3-58
- “Outer and Inner Instrument Covers and Associated Parts” on page 3-59

**Front Panel View**

**Table 3-2 Front Panel View**

Item No.	Description	Qty	Part Number
1	Small Overlay (E8247C, E8257C and E8267C Option 1EM)	1	E4400-80011
	Small Overlay (E8267C) Option UNM	1	E4400-80006
2	Nameplate - E8247C 20 GHz	1	E8251-80206
	Nameplate - E8247C 40 GHz	1	E8251-80209
	Nameplate - E8257C 20 GHz	1	E8251-80205
	Nameplate - E8257C 40 GHz	1	E8251-80208
	Nameplate - E8267C 20GHz	1	E8251-80204
3	RPG Knob	1	E4400-40003
4	Large Keypad Overlay (E8247C) Option UNM	1	E8251-80008
	Large Keypad Overlay (E8257C) Option UNM	1	E8251-80001
	Large Keypad Overlay (E8267C) Option UEM	1	E8251-80201
	Large Keypad Overlay (E8247C) Option 1EM	1	E8251-80050
	Large Keypad Overlay (E8257C) Option 1EM	1	E8251-80014
	Large Keypad Overlay (E8267C) Option 1EM	1	E8251-80202
5	Nut-Hex 15/32-32		2950-0035
	E8247C	4	
	E8257C	7	
6	Washer-Wavy .490ID		3050-1919
	E8247C	4	
	E8257C	7	
7	E8267C	12	
	Washer-Shoulder	2	00310-48801
8	Bottom Overlay (E8247C) Option UNM	1	E8251-80009
	Bottom Overlay (E8257C and E8267C) Option UNM	1	E8251-80003
	Bottom Overlay (E8247C, E8257C and E8267C) Option 1EM	1	E8251-80203

**Figure 3-23**      **Front Panel View**



p-se939a

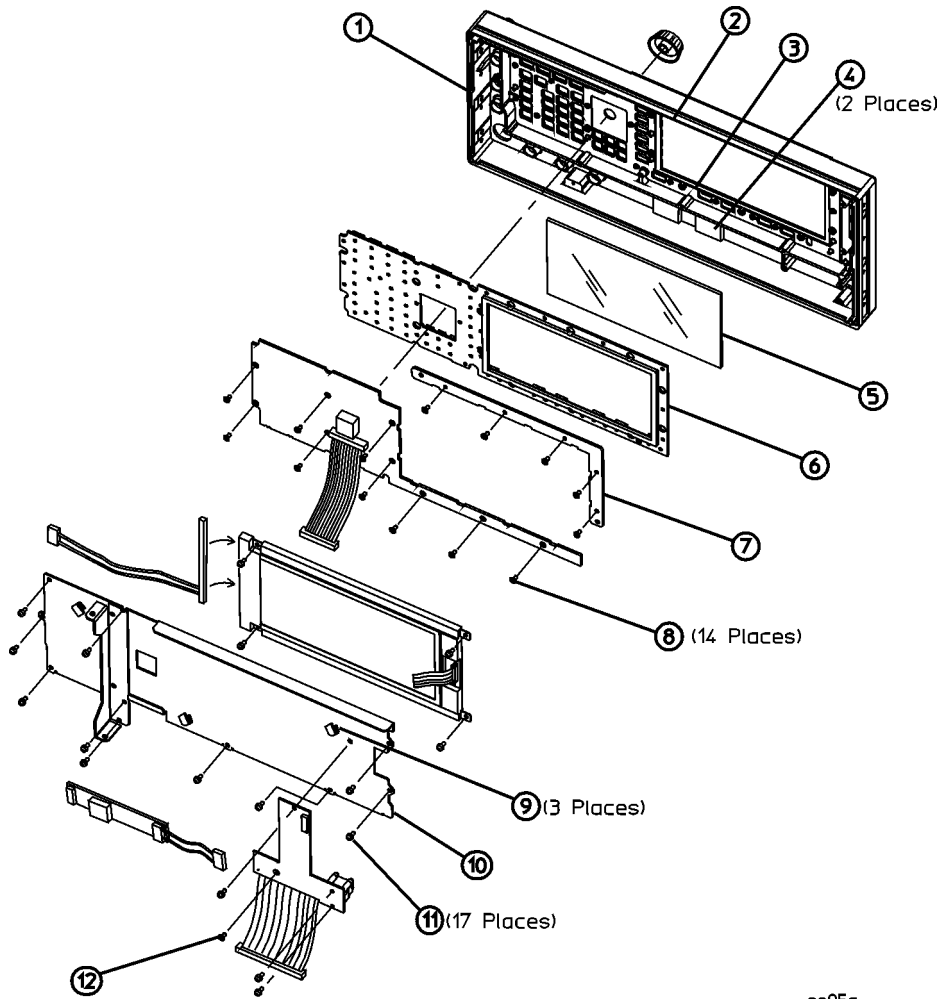
**Disassembled Front Panel View**

**Table 3-3 Disassembled Front Panel View**

<b>Item No.</b>	<b>Description</b>	<b>Qty</b>	<b>Part Number</b>
1	Front Panel Frame	1	E8251-20102
2	Gasket RFI Round Mesh .125 inch	1	8160-0660
3	Gasket RFI Round Mesh .062 inch	1	8160-0723
4	Velcro Attachment	1	0510-1303
5	Glass Filter 70% Xmt	1	4330-1711
6	Rubber Keypad CW (E8247C)	1	E8251-40009
	Rubber Keypad Analog (E8257C)	1	E8251-40006
	Rubber Keypad Vector (E8267C)	1	E8251-40200
7	Bracket Filter	1	E4400-00009
8	Screw-Machine M3.0 x 08 FL-TX	14	0515-1227
9	Cable Retainer Clip	3	1400-1439
10	Sub Panel	1	E8251-00009
11	Screw-Machine M3.0 x 06 CW-PN-TX	17	0515-0372
12	Screw-Machine M3.0 x 08 FL-TX	1	0515-1035



Figure 3-24 Disassembled Front Panel View



se95a

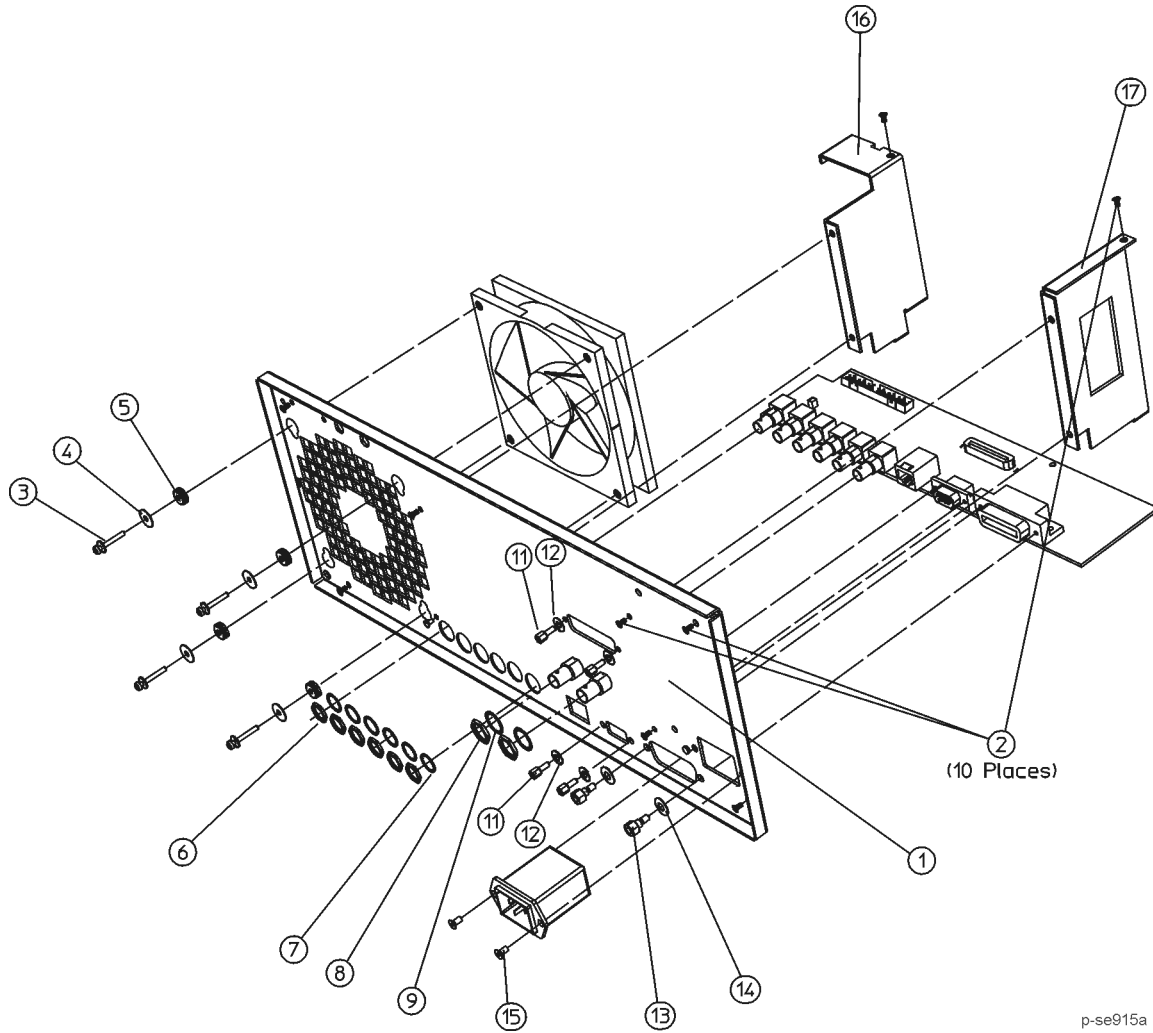
**Disassembled Rear Panel View****Table 3-4 Disassembled Rear Panel View**

Item No.	Description	Qty	Part Number
1	Rear Panel (E8247C and E8257C) Option UNM	1	E8251-00020
	Rear Panel (E8247C and E8257C) Option 1EM	1	E8251-00013
	Rear Panel (E8267C) Option UNM	1	E8251-00021
	Rear Panel (E8267C) Option 1EM	1	E8251-00022
2	Screw-Machine M3.0 8 CW-PN-TX (mounting screws for rear-panel and rear struts) E8247C/57C E8267C	10	0515-0372
		14	
3	Screw-Machine M3.0 14CW-PN-TX (screw to mount B1 fan to rear-panel)	4	0515-0665
4	Beveled Washer (fan)	4	3050-1628
5	Grommet (fan)	4	0400-0356
6	Nut-Hex 1/2-28 (6 BNC connectors on rear-panel board)	6	2950-0054
7	Washer Lock .505ID (6 BNC connectors on rear-panel)	6	2190-0068
8	Nut-Hex 15/32-32 (10 MHz In/Out BNC connectors) E8247C E8257C E8267C	3	2950-0035
		9	
		26	
9	Washer .490ID (10 MHz In/Out BNC connectors) E8247C E8257C E8267C	3	3050-1919
		9	
		26	
10	Rear-Panel BNC Hole Plug (E8267C)	1	6960-0002
11	Standoff Screw-Hex .321I 4-40ss (Auxiliary Interface and SMI) E8247C/57C E8267C	4	0380-2079
		6	
12	Split Lock Washer .115ID 4 (Auxiliary Interface and SMI) E8247C/57C E8267C	4	2190-0003
		6	
13	Standoff Screw-Hex .327 6-32 (GPIB interface)	2	0380-0644
14	Split Lock Washer .194ID 10 (GPIB interface)	2	2190-0577
15	Screw-Machine M3.0 8 FL-TX (line module)	2	0515-1035
16	Right Rear Strut (E8247C and E8257C)	1	E8251-00006
	Right Rear Strut (E8267C)	1	E8251-00201

**Table 3-4 Disassembled Rear Panel View**

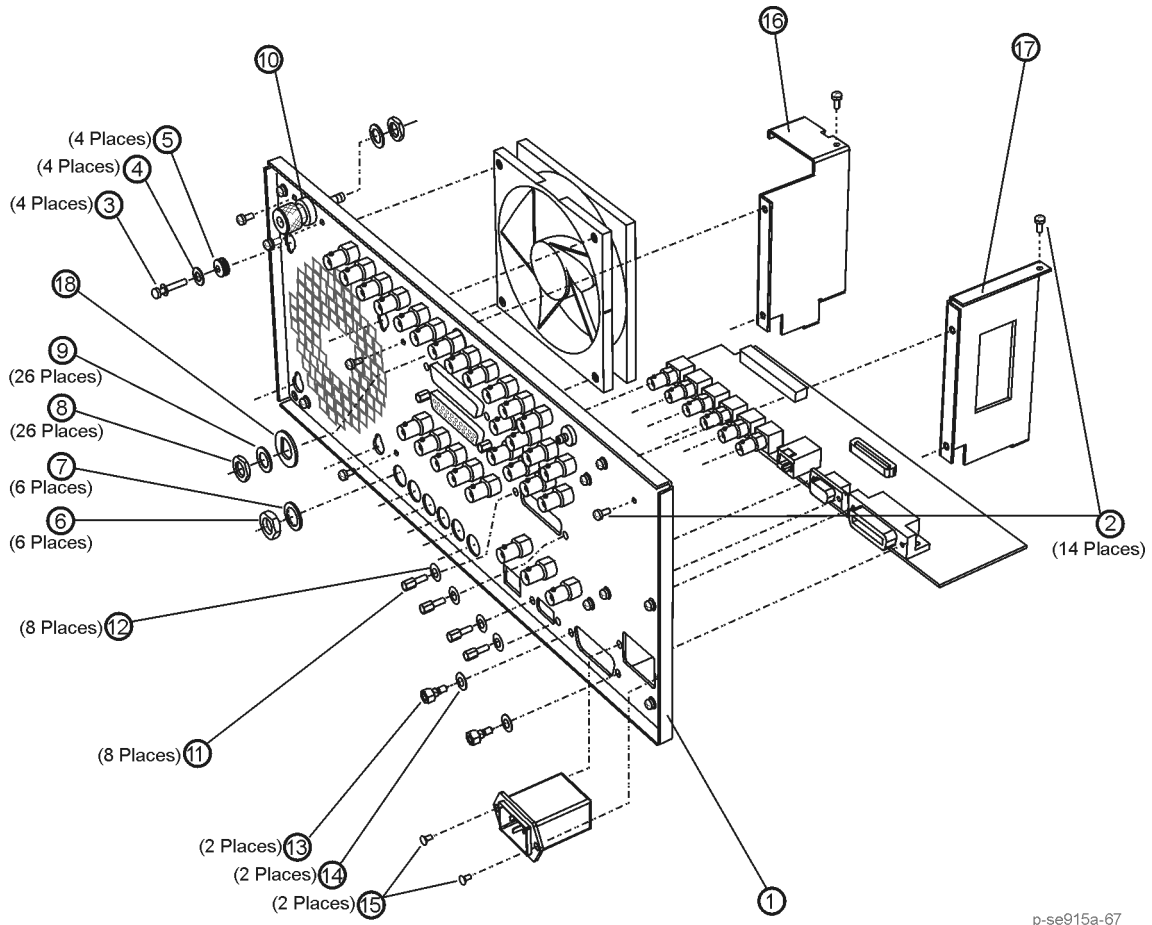
Item No.	Description	Qty	Part Number
17	Left Rear Strut (E8247C and E8257C)	1	E8251-00030
	Left Rear Strut (E8267C)	1	E8251-00200
18	Shouldered Washer (E8267C)	1	00310-48801

**Figure 3-25 E8247C/57C Disassembled Rear Panel View**



p-se915a

Figure 3-26 E8267C Disassembled Rear Panel View



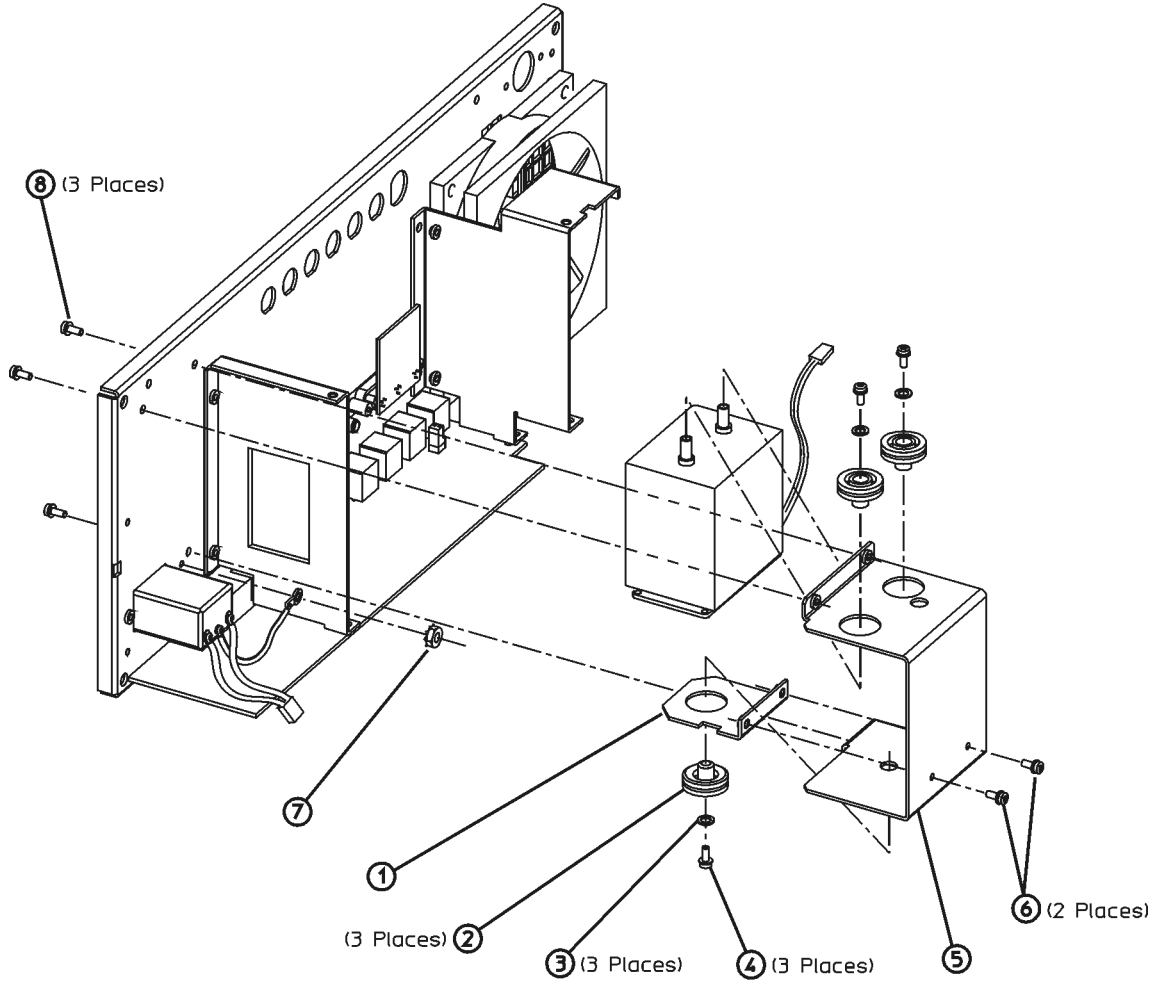
p-se915a-67

**Disassembled A32 10 MHz Crystal Oscillator (Option UNR)**

**Table 3-5 Disassembled A32 10 MHz Crystal Oscillator (Option UNR)**

Item No.	Description	Qty	Part Number
1	C-Bracket	1	E8251-00040
2	Shock Mount	3	1520-0205
3	Flathead Washer	3	3050-0105
4	Screw-Machine 4.0 x 40 .250	3	2200-0103
5	L-Bracket	1	E8251-00041
6	Screw-Machine M3.0 x 8 CW-PN-TX	2	0515-0372
7	Nut-Hex M3.0 (line module ground)	1	0535-0031
8	Screw-Machine M3.0 x 8 CW-PN-TX	2	0515-0372

Figure 3-27 Disassembled A32 10 MHz Crystal Oscillator (Option UNR)



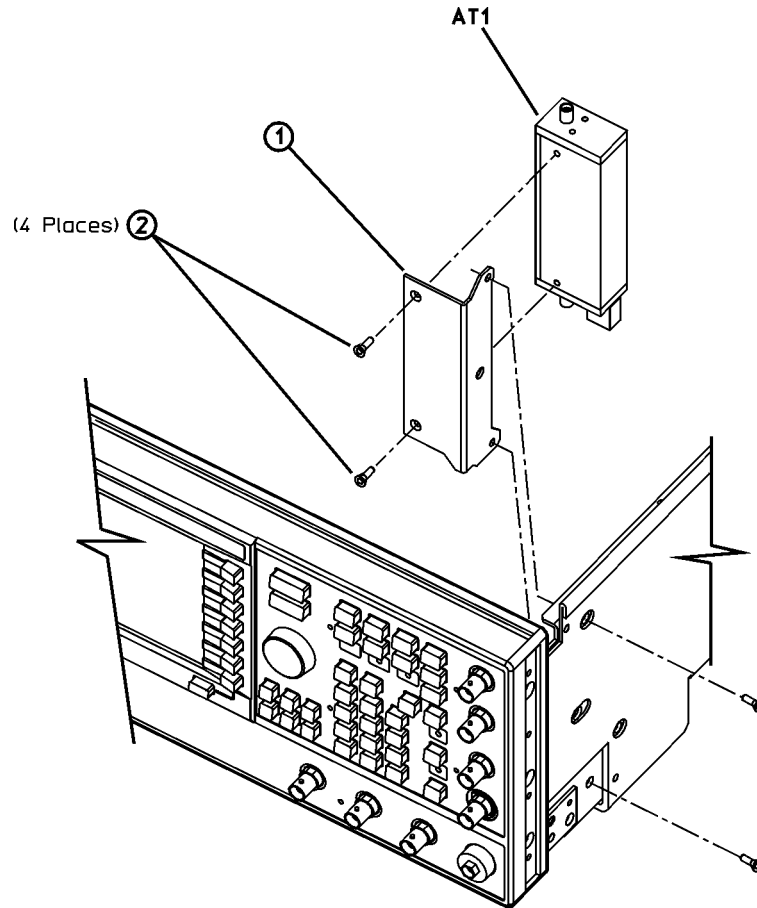
p-se925a

### Disassembled AT1 115 dB Attenuator View (Option 1E1)

Table 3-6 Disassembled AT1 115 dB Attenuator View (Option 1E1)

Item No.	Description	Qty	Part Number
1	Bracket	1	E8251-00038
2	Screw-Machine M3.0 x 8 FL-TX	4	0515-1035

Figure 3-28 Disassembled AT1 115 dB Attenuator View (Option 1E1)



se941a

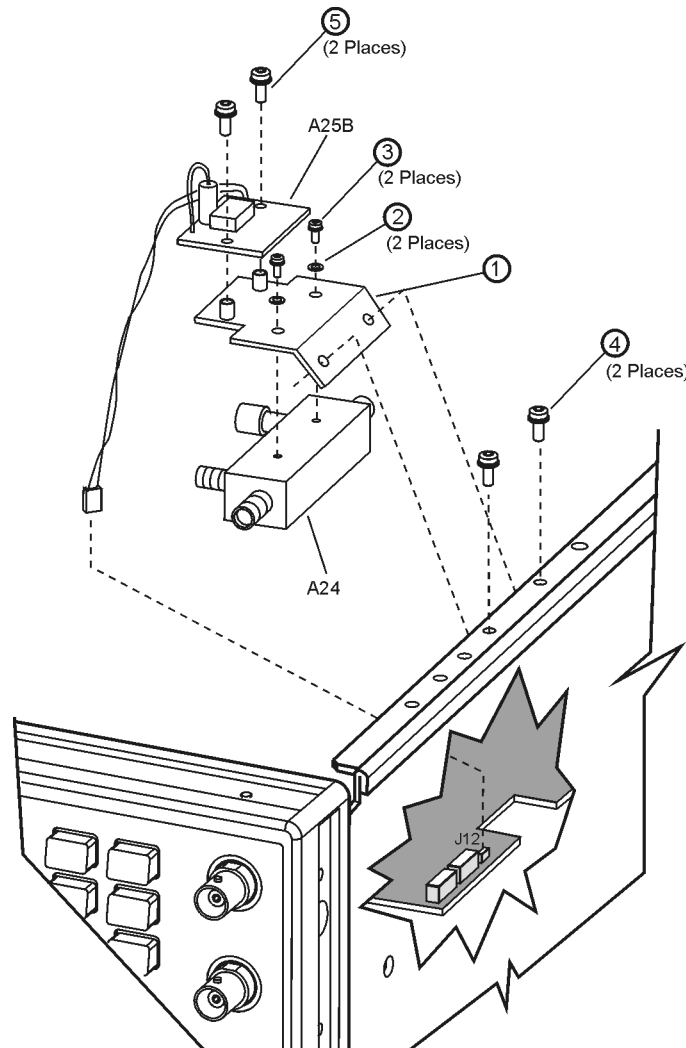


## Disassembled A24 20 GHz High Band Coupler and A25B Highband Detector Bias Board

Table 3-7 Disassembled A24 20 GHz High Band Coupler and A25B Highband Detector Bias Board

Item No.	Description	Qty	Part Number
1	Coupler Bracket (Option 520)	1	E8251-00212
2	Washer Lock M2.0	2	2190-0654
3	Screw-Machine SM 256 .250 PN-PN	2	0520-0128
4	Screw-Machine M3.0 x 8 FL-TX	2	0515-1035
5	Screw-Machine M3.0 x 8 CW-PN-TX	2	0515-0372

Figure 3-29 Disassembled A24 20 GHz High Band Coupler and A25B Highband Detector Bias Board

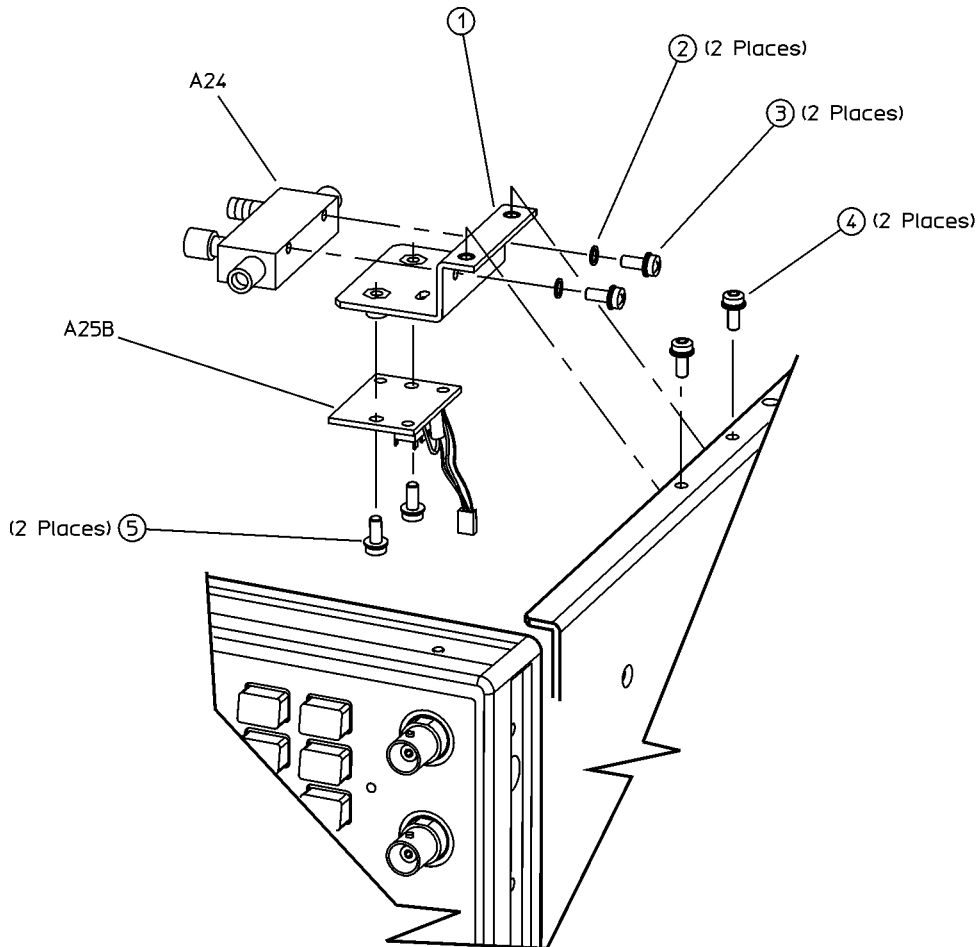


## Disassembled A24 40GHz High Band Coupler and A25B High Band Detector Bias Board

Table 3-8 Disassembled A24 High Band Coupler and A25 High Band Detector

Item No.	Description	Qty	Part Number
1	Coupler Bracket (Option 540)	1	E8251-00039
2	Washer Lock M2.5	2	2190-0583
3	Screw-Machine M4.0 x .312 PN-PN	2	2200-0141
4	Screw-Machine M3.0 x 8 FL-TX	2	0515-1035
5	Screw-Machine M3.0 x 8 CW-PN-TX	2	0515-0372

Figure 3-30 Disassembled A24 40GHz High Band Coupler and A25B High Band Detector Bias Board



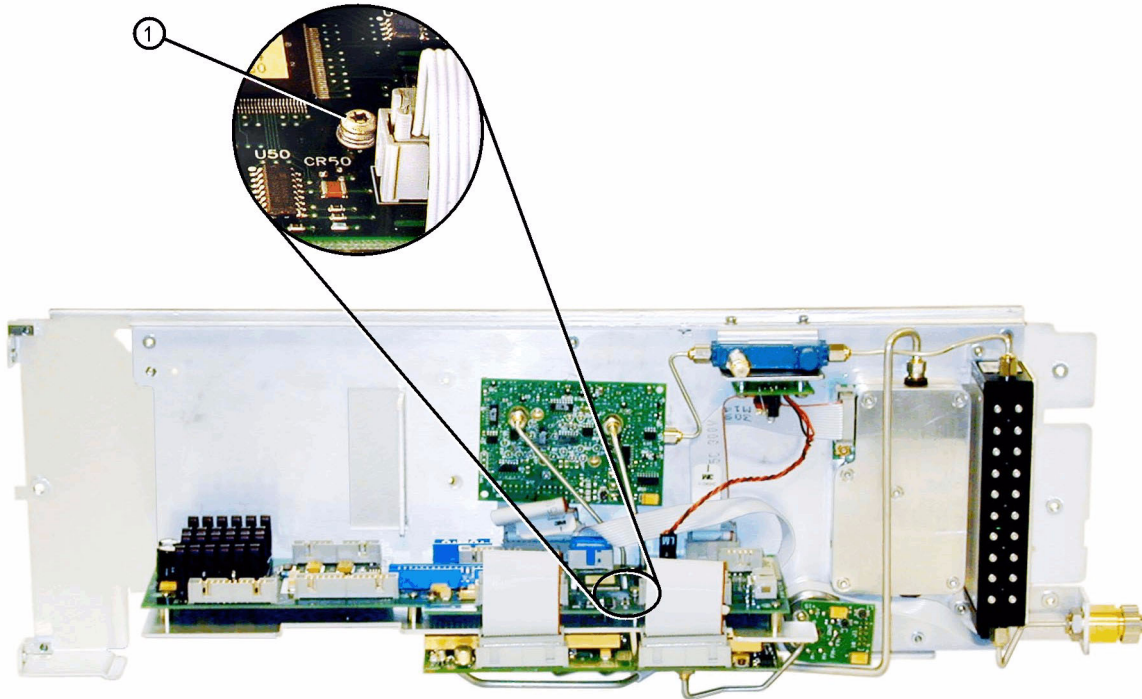
se923a

### Microcircuit Interface Deck Top View

Table 3-9 Microcircuit Interface Deck Top View

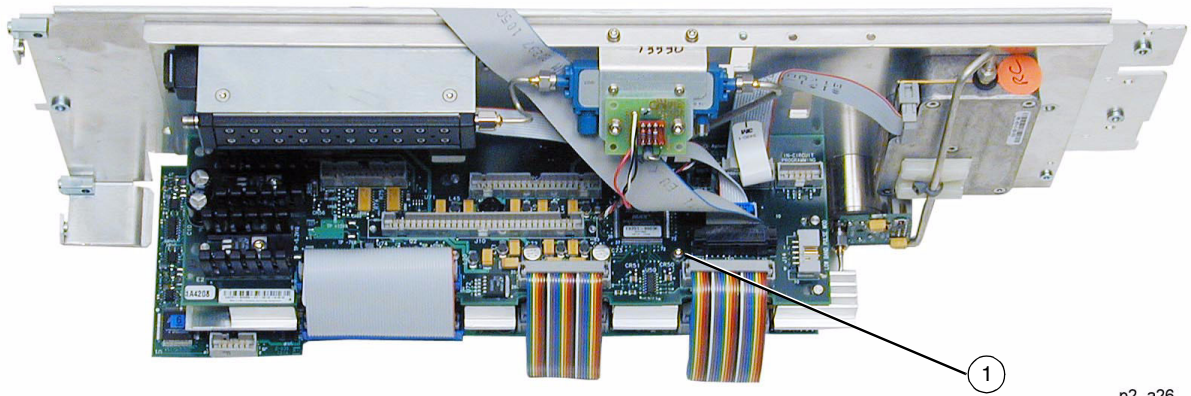
Item No.	Description	Qty	Part Number
1	Screw-Machine M3.0 x 14 CW-PN-TX	1	0515-0665

Figure 3-31 E8247C/57C Microcircuit Interface Deck Top View



se955a

Figure 3-32 E8267C Microcircuit Interface Deck Top View



p2\_a26

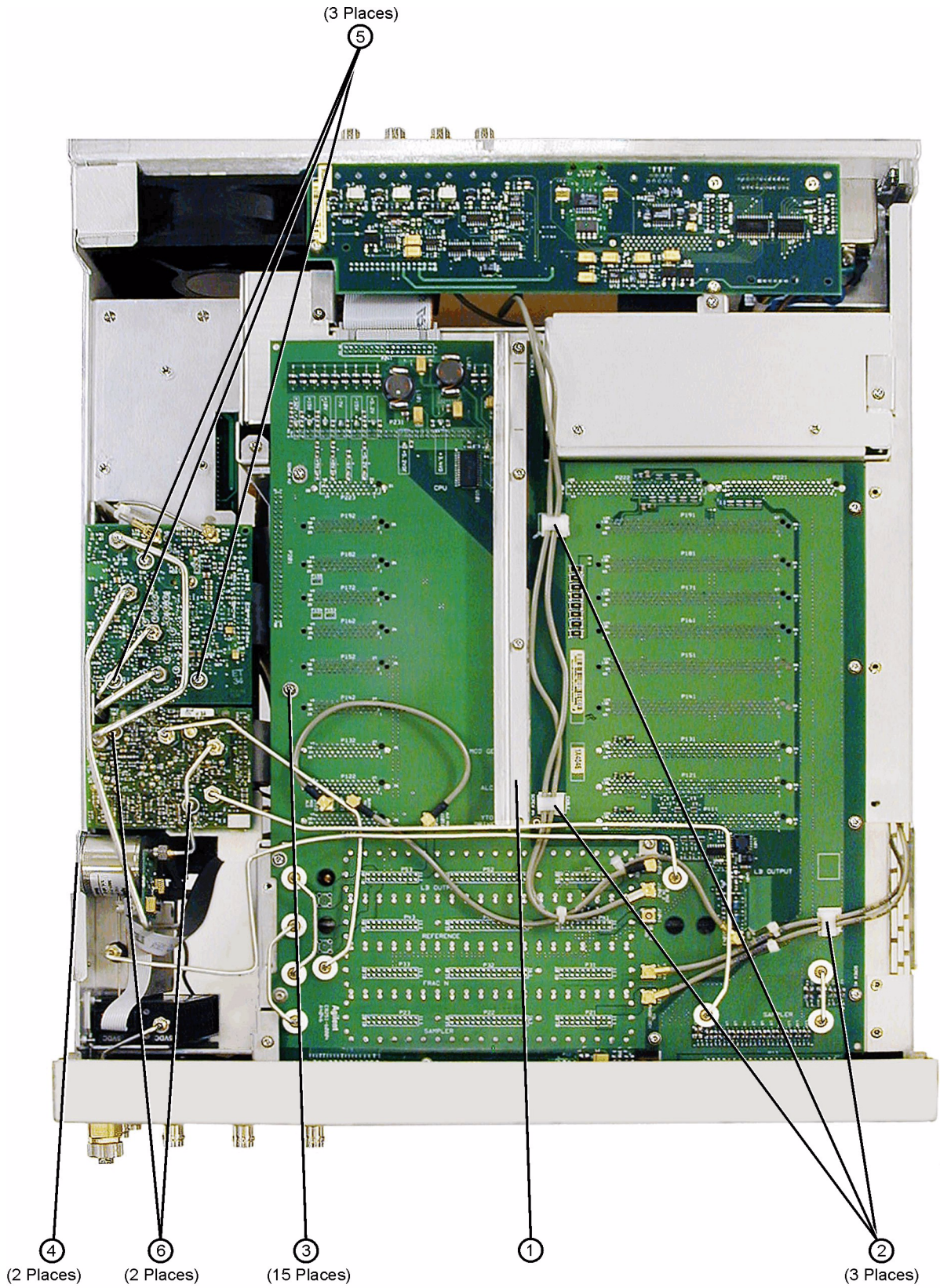
## Main Chassis and MID Bottom View

**Table 3-10** Main Chassis and MID Bottom View

Item No.	Description	Qty	Part Number
1	Rib Bracket	1	E8251-00008
2	Cable Retainer Clip E8247C/57C E8267C	3 4	E8251-40001
3	Screw-Machine M30. x 8 CW-PN-TX (A31 Motherboard to main chassis)	13	0515-0372
4	Screw-Machine M30. x 8 CW-PN-TX (A28 YIG Oscillator to MID)	2	0515-0372
5	Screw-Machine M30. x 20 CW-PN-TX (A30 Modulator Filter with Standard or High Power to MID)	3	0515-1410
6	Screw-Machine M30. x 20 CW-PN-TX (A29 20 GHz Doubler to MID)	2	0515-1410
7	Screw-Machine M30. x 20 CW-PN-TX (A13 I/Q MUX to MID) (E8267C)	3	0515-1410

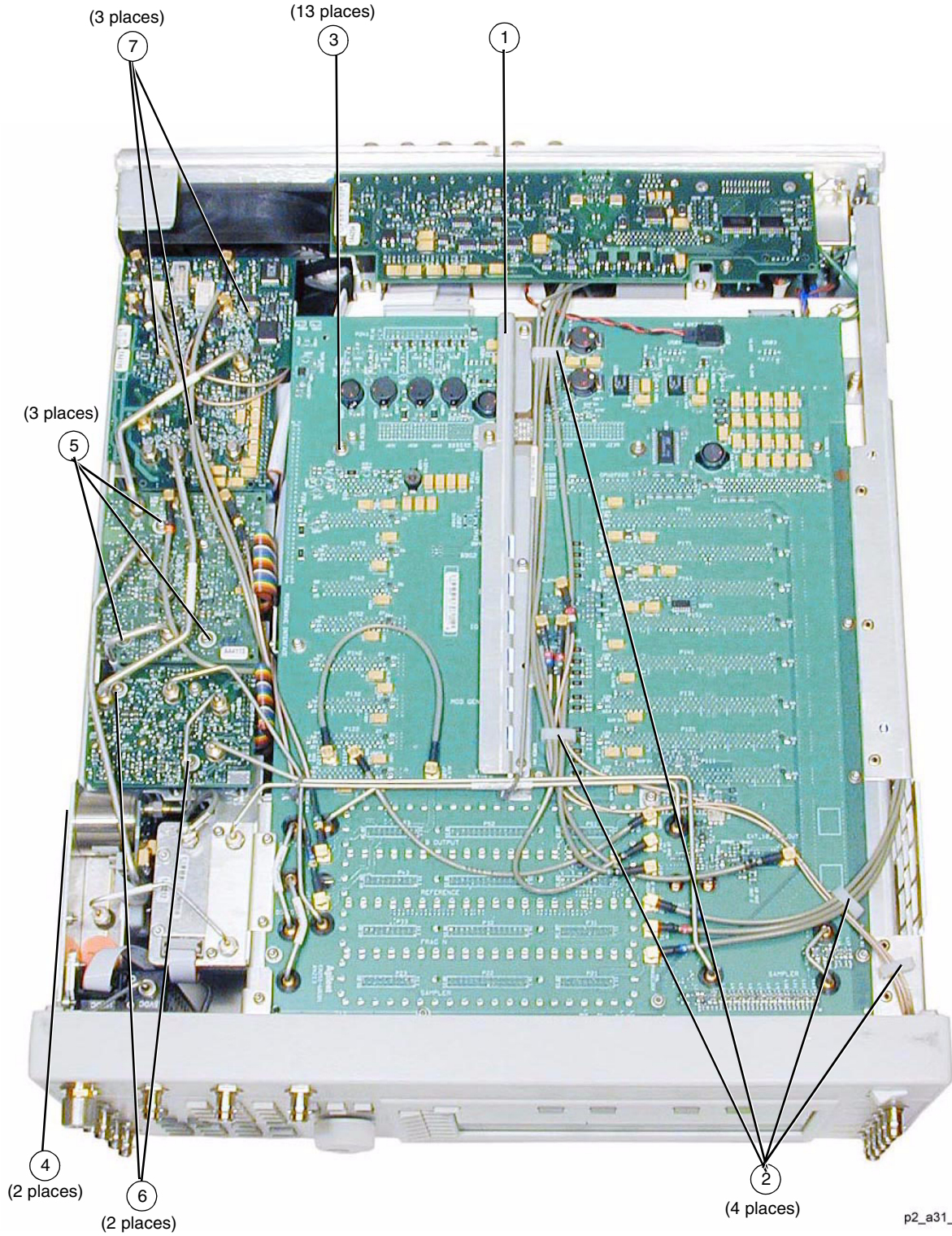


**Figure 3-33 Main Chassis and MID Bottom View (E8247C/57C)**





**Figure 3-34 Main Chassis and MID Bottom View (E8267C)**



p2\_a31\_dig

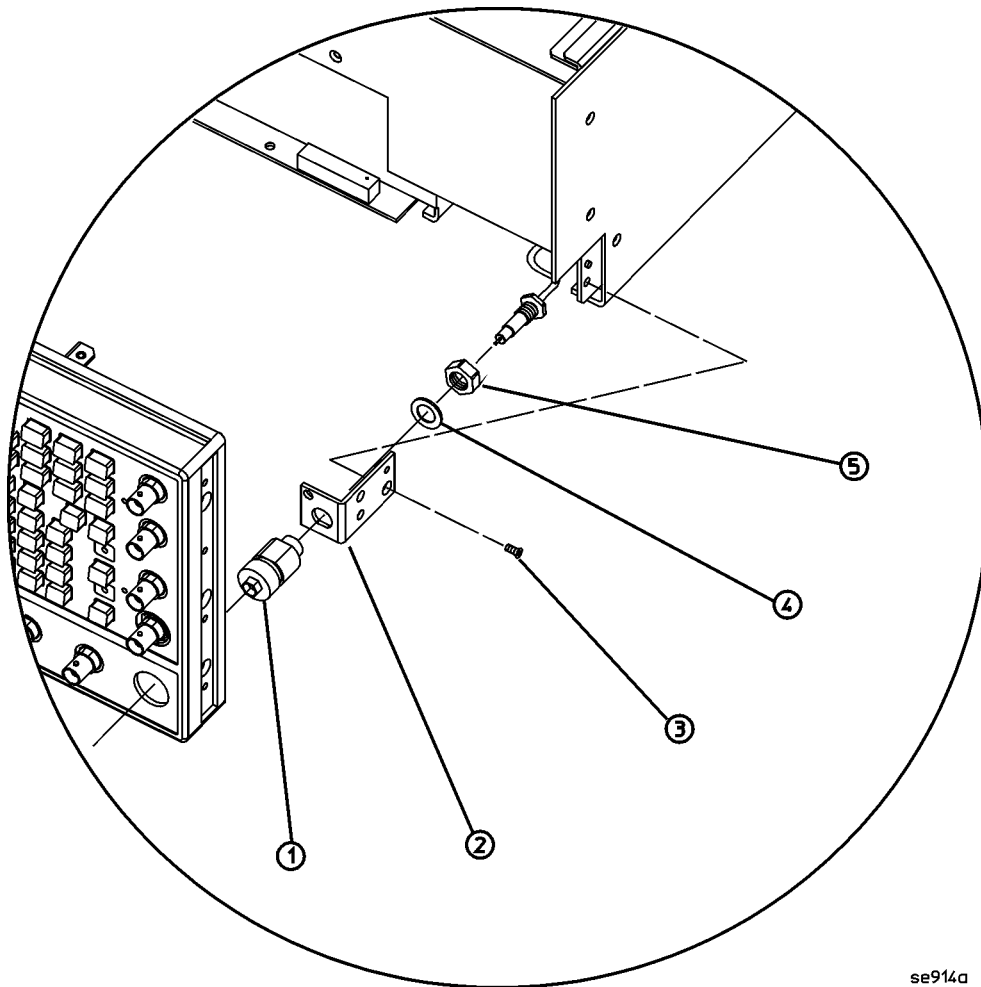


### 2.4 mm RF Output Connector (Option 540 Only)

Table 3-11 2.4 mm RF Output Connector (Option 540 Only)

Item No.	Description	Qty	Part Number
1	Adapter-Male 2.4 mm	1	5063-1700
2	Adapter Bracket	1	E8251-00018
3	Screw-Machine M4.0 x 10 FL-TX (front frame to adapter bracket)	1	0515-1269
4	Washer lock .377ID	1	2190-0016
5	Nut-Hex	1	E8251-20067
	W25 Semi-Rigid Cable (refer to <a href="#">Table 3-1 on page 3-20.</a> )		

Figure 3-35 2.4 mm RF Output Connector (Option 540 Only)



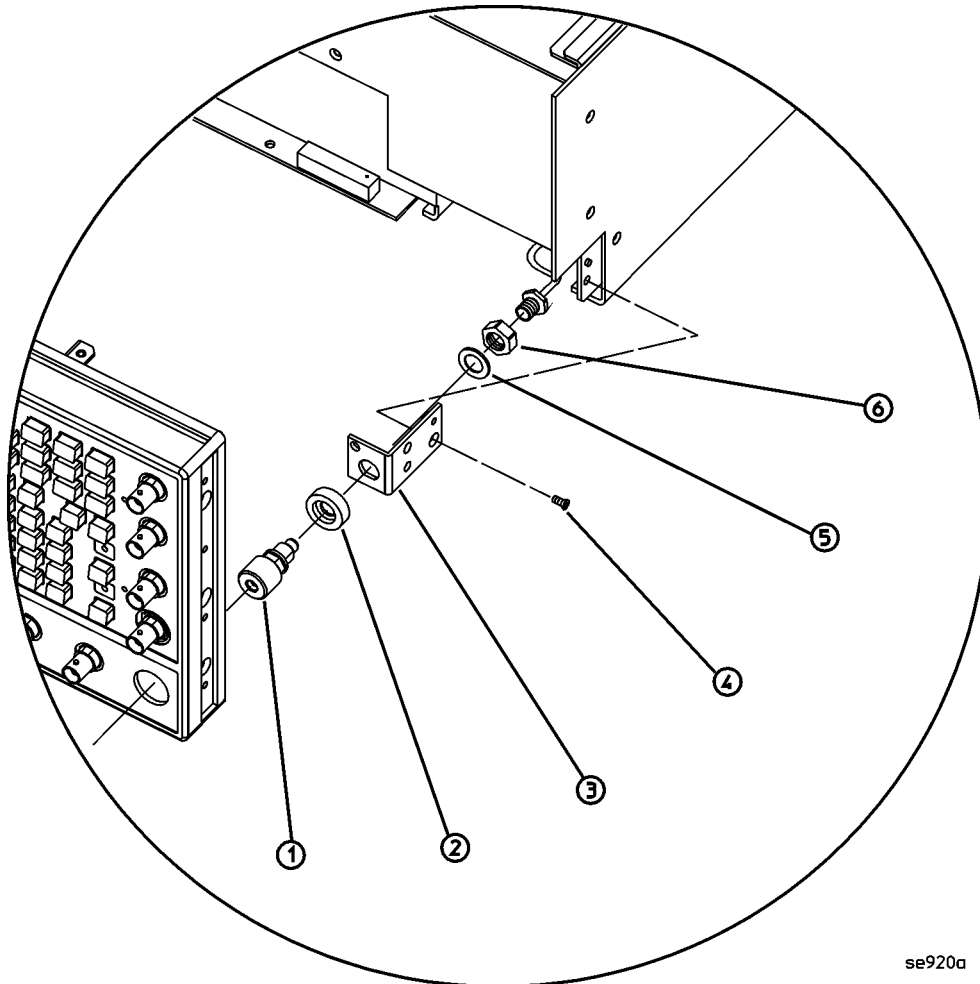
se914a

**APC 3.5 RF Output Connector (Option 520 Only)**

**Table 3-12 APC 3.5 RF Output Connector (Option 520 Only)**

Item No.	Description	Qty	Part Number
1	Adapter-Male APC 3.5	1	08673-60040
2	Spacer APC 3.5	1	E8251-20068
3	Adapter Bracket	1	E8251-00016
4	Screw-Machine M4.0 x 10 FL-TX	1	0515-1269
5	Washer lock .377ID	1	2190-0016
6	Nut-Hex	1	2950-0001
	W25 Semi-Rigid Cable (refer to <a href="#">Table 3-1 on page 3-20.</a> )		

**Figure 3-36 APC 3.5 RF Output Connector (Option 520 Only)**



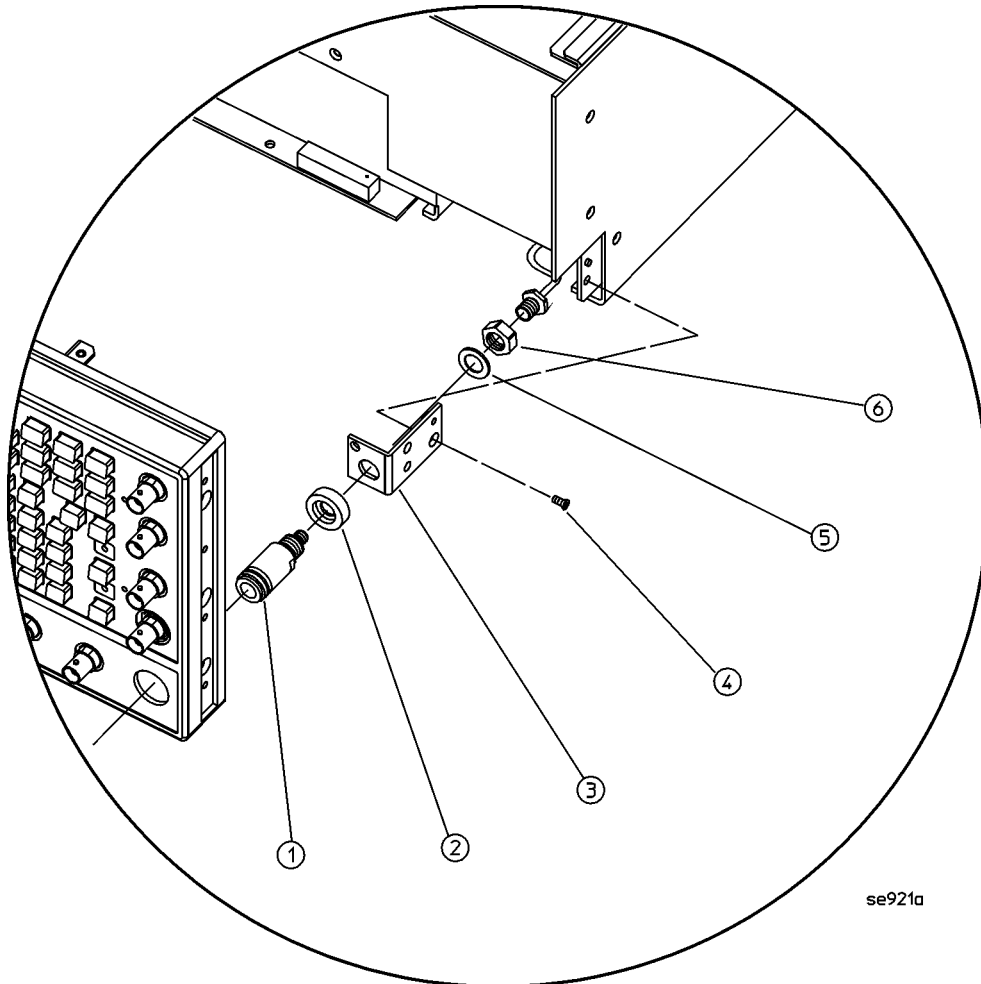
se920a

**Type-N RF Output Connector (Option 1ED Models Only)**

**Table 3-13 Type-N RF Output Connector (Option 1ED Models Only)**

Item No.	Description	Qty	Part Number
1	Adapter-Type-N (f)	1	08559-60002
2	Spacer	1	E8251-20067
3	Adapter Bracket	1	E8251-00018
4	Screw-Machine M4.0 x 10 FL-TX	1	0515-1035
5	Washer lock	1	2190-0102
6	Nut-Hex	1	2950-0132
	W25 Semi-Rigid Cable (refer to <a href="#">Table 3-1 on page 3-20.</a> )		

**Figure 3-37 Type-N RF Output Connector (Option 1ED Models Only)**



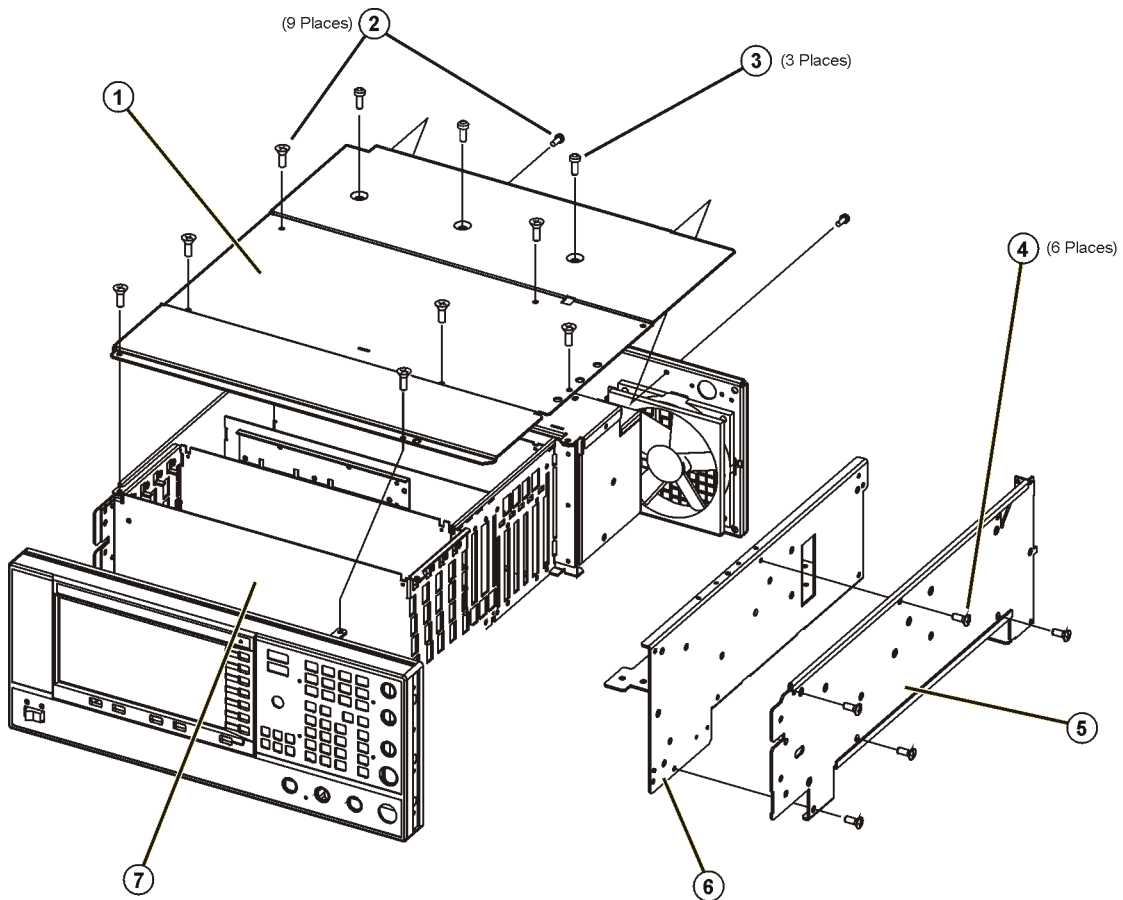
se921a

### Main Chassis with Inside Cover and Right-Side Support Wall

**Table 3-14** Main Chassis with Inside Cover and Right-Side Support Wall

Item No.	Description	Qty	Part Number
1	Main Chassis Inside Top Cover	1	E8251-00011
2	Screw-Machine M3.0 x 08 FL-TX (inside top cover to main chassis and rear panel)	9	0515-0430
3	Screw-Machine M3.0 x 08 CW-PN-TX (rear panel to right-side support wall)	3	0515-0372
4	Screw-Machine M3.0 x 08 FL-TX (microcircuit interface deck to right-side support wall)	6	0515-1035
5	Right-Side Support Wall	1	E8251-00014
6	Microcircuit Interface Deck	1	E8251-00004
7	Main Chassis	1	E8251-60030

**Figure 3-38** Main Chassis with Inside Cover and Right-Side Support Wall



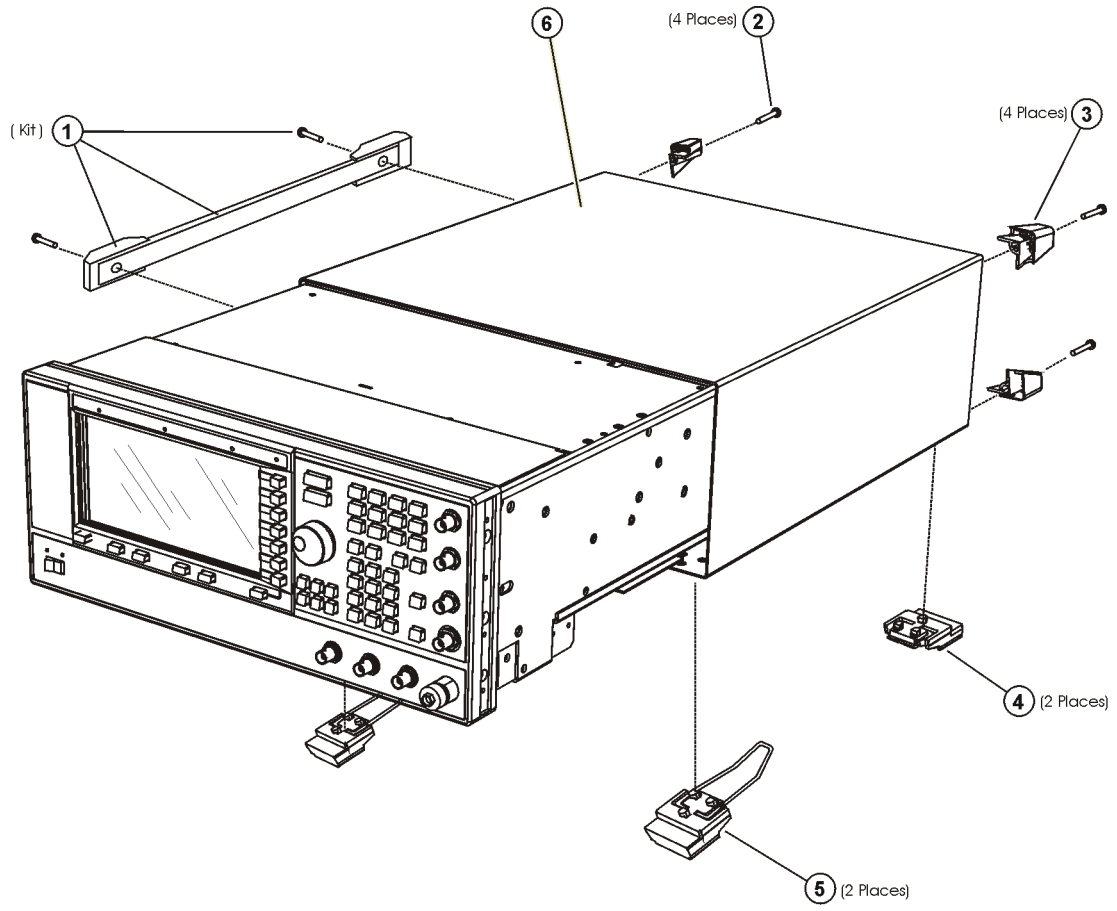
p-se931a

## Outer and Inner Instrument Covers and Associated Parts

**Table 3-15**                      **Outer and Inner Instrument Covers and Associated Parts**

Item No.	Description	Qty	Part Number
1	Assy-Strap Handle - includes the following parts:	1	E8251-60067
	Strap Assembly	1	
	Ground Spring	2	
	Handle Retainer	2	
	End Cap	2	
	Screw-Machine M5 x 18 FL-TX	2	
2	Rear Feet Screws	4	0515-1619
3	Rear-Panel Feet	4	5041-9611
4	Feet-Bottom	4	5041-9167
5	Tilt Stand	2	1460-1345
6	Outside Instrument Cover	1	E8251-00012

**Figure 3-39** Outer and Inner Instrument Covers and Associated Parts



se92a

## Miscellaneous

This section lists part numbers for miscellaneous items that can be used with your signal generator.

### Accessories

**Table 3-16**            **Accessories**

Description	Part Number
Test Cable (extension cable for accessing A31 Motherboard coax connectors)	E8251-20088

### Documentation

**Table 3-17**            **Documentation**

Description	Part Number
PSG Documentation Set	E8251-90250
CD-ROM Documentation	E8251-90251
Installation Guide	E8251-90252
User's Guide	E8251-90253
Key Reference	E8251-90254
Programming Guide	E8251-90255
SCPI Command Reference	E8251-90256
Error Messages	E8251-90257
Calibration Guide	E8251-90258
Service Guide	E8251-90259
Specifications/Data Sheet	5988-7454EN
Specifications/Data Sheet	5988-6632EN



## Electrostatic Discharge (ESD) Protective Supplies

**Table 3-18** Electrostatic Discharge (ESD) Protective Supplies

Description	Part Number
ESD connector end cap front-panel RF output	1401-0247
ESD connector end cap rear panel SMI	1252-4690
ESD connector end cap-GPIB	1252-5007
ESD connector end cap coherent carrier cut	1252-4696
2 X 4 Ft. Antistatic Table Mat with 15 FT. Ground Wire	9300-0797
5 Ft. Grounding Cord (for wrist strap)	9300-0980
Adjustable Antistatic Wrist Strap	9300-1367

## Abbreviations Used in Part Descriptions

This section defines the reference designators, abbreviations, and option numbers that are used in the part descriptions throughout this chapter.

Reference Designator	Definition
A	assembly
AT	attenuator
B	fan
DS	lamp
J	electrical connector; jack
W	cable; transmission path; wire

Abbreviation	Definition
BN	buttonhead (screws)
CPU	central processing unit
CW	conical washer (screws)
EXT	external
FL	flathead (screws)
Ft	feet
Hex	hexagonal
GPIB	general purpose interface bus
HX	hexagonal recess (screws)
I	in-phase
LF	low frequency
M	meters or metric hardware
PC	patch lock (screws) or printed circuit
PN	panhead (screws)
Q	quadrature
Qty	quantity
RF	radio frequency
RPP	reverse power protection
SMA	subminiature type-A
TX	TORX recess (screws)



---

## 4 Post-Repair Procedures

- “Adjustments: Assemblies A1—A12” on page 4-2
- “Adjustments: Assemblies A13—A26” on page 4-3
- “Adjustments: Assemblies A27—A35, AT1, B1, and RF Output Connector” on page 4-4
  
- “Performance Tests: Assemblies A1—A18” on page 4-5
- “Performance Tests: Assemblies A19—A32” on page 4-6
- “Performance Tests: Assemblies A34, A35, AT1, B1, and RF Output Connector” on page 4-7

## Post-Repair Procedures Matrix

Table 4-1 Adjustments: Assemblies A1—A12

Adjustments	Replaced Assembly														
	A1 Keyboard	A2 Display	A2DS1 Display Backlight	A3 Power Switch	A4 Inverter	A5 Sampler	A6 Frac-N	A7 Reference (Standard)	A7 Reference (UNR)	A8 Output (Analog)	A8 Output (Digital)	A9 YIG Driver	A10 ALC	A11 Pulse/Analog Mod Gen	A12 Low Band Fast Pulse 1E6
The following adjustments are listed in the order that they should be performed for proper calibration.															
ADC Calibration						✓	✓	✓		✓	✓	✓	✓	✓	
YIG-Driver Pre-Tune Calibration												✓			
VCO Bias Frac-N Calibration							✓								
Internal Source Calibration														✓	
AM Audio Path Offset Calibration													✓	✓	
KV vs. Frequency Calibration							✓								
Timebase Calibration (Non UNR/UNJ Options)								✓							
FM Scale Offset Calibration							✓					✓		✓	
FM Path Offset Calibration							✓					✓		✓	
FM In-band Offset Calibration							✓					✓		✓	
FM Inverting Amplifier Offset Calibration														✓	
FM 1/2 Path Ratio Gain Calibration							✓					✓		✓	
Mod Source Relative Gain Calibration							✓					✓		✓	
FM/PM Out-of-Band Calibration							✓					✓		✓	
FM/PM YO Frequency Compensation Calibration							✓					✓		✓	
DC FM Calibration							✓					✓		✓	
Low Frequency Output Calibration														✓	
External Input Peak Detector Calibration														✓	
ALC Dynamic Calibration										✓	✓		✓		✓
Power Flatness Calibration										✓	✓		✓		✓
Attenuator Calibration															
ALC Modulator Calibration										✓	✓		✓		
AM Gain Calibration										✓	✓		✓	✓	
LB Digital Prelevel Gain Calibration											✓				
LB Digital Mixer Bias Calibration											✓				
LB Digital Gain Calibration											✓				
Gain Adjustment Bypass Calibration (Frequencies. ≤3.2 GHz)							✓			✓	✓	✓			
IQ 20 Prelevel Gain Mixer Bias, & Digital Gain Cal.															
IQ Impairment Calibration											✓				
Pulse Width Calibration										✓	✓			✓	✓
IQ Power Floor Calibration											✓				
Target IQ Power Calibration											✓				
1/f Corner Calibration											✓				

**Table 4-2 Adjustments: Assemblies A13—A26**

Adjustments	Replaced Assembly													
	A13 IQ Multiplexer	A14 Baseband Generator	A18 CPU	A19 Power Supply	A20 SMI [Source Module Interface]	A21 Rear Panel	A22 Line Module	A23 Lowband Coupler/Detector	A24 20 GHz Coupler	A24 40 GHz Coupler	A25 20 GHz Detector	A25 40 GHz Detector	A25B Detector Bias Board	A26 MID
The following adjustments are listed in the order that they should be performed for proper calibration.														
ADC Calibration			✓											✓
YIG-Driver Pre-Tune Calibration														
VCO Bias Frac-N Calibration														
Internal Source Calibration														
AM Audio Path Offset Calibration														
KV vs. Frequency Calibration														
Timebase Calibration (Non UNR/UNJ Options)														
FM Scale Offset Calibration														
FM Path Offset Calibration														
FM In-band Offset Calibration														
FM Inverting Amplifier Offset Calibration														
FM 1/2 Path Ratio Gain Calibration														
Mod Source Relative Gain Calibration														
FM/PM Out-of-Band Calibration														
FM/PM YO Frequency Compensation Calibration														
DC FM Calibration														
Low Frequency Output Calibration														
External Input Peak Detector Calibration														
ALC Dynamic Calibration								✓	✓	✓	✓	✓	✓	
Power Flatness Calibration	✓							✓	✓	✓	✓	✓	✓	
Attenuator Calibration	✓													
ALC Modulator Calibration														
AM Gain Calibration														
LB Digital Prelevel Gain Calibration	✓													
LB Digital Mixer Bias Calibration	✓													
LB Digital Gain Calibration	✓													
Gain Adjustment Bypass Calibration (Frequencies. ≤3.2 GHz)														
IQ 20 Prelevel Gain Mixer Bias, & Digital Gain Cal.	✓	✓												
IQ Impairment Calibration	✓	✓												
Pulse Width Calibration														
IQ Power Floor Calibration	✓													
Target IQ Power Calibration	✓													
1/f Corner Calibration	✓													

**Table 4-3 Adjustments: Assemblies A27—A35, AT1, B1, and RF Output Connector**

Adjustments	Replaced Assembly										
	A27 40 GHz Doubler	A28 YIG Oscillator	A29 20 GHz Doubler	A30 Mod Filter	A31 Motherboard	A32 10 MHz Crystal Oscillator	A34 Internal Hard Drive	A35 3 – 20 IQ Modulator	AT1 115 dB Attenuator	B1 Fan	RF Output Connector
The following adjustments are listed in the order that they should be performed for proper calibration.											
ADC Calibration											
YIG-Driver Pre-Tune Calibration		✓									
VCO Bias Frac-N Calibration											
Internal Source Calibration											
AM Audio Path Offset Calibration											
KV vs. Frequency Calibration											
Timebase Calibration											
FM Scale Offset Calibration		✓									
FM Path Offset Calibration		✓									
FM In-band Offset Calibration		✓									
FM Inverting Amplifier Offset Calibration											
FM 1/2 Path Ratio Gain Calibration		✓									
Mod Source Relative Gain Calibration		✓									
FM/PM Out-of-Band Calibration											
FM/PM YO Frequency Compensation Calibration		✓									
DC FM Calibration		✓									
Low Frequency Output Calibration											
External Input Peak Detector Calibration		✓									
ALC Dynamic Calibration				✓							
Power Flatness Calibration				✓				✓	✓		✓
Attenuator Calibration								✓			
ALC Modulator Calibration				✓				✓			
AM Gain Calibration				✓							
LB Digital Prelevel Gain Calibration											
LB Digital Mixer Bias Calibration											
LB Digital Gain Calibration											
Gain Adjustment Bypass Calibration (Frequencies ≤3.2 GHz)											
IQ 20 Prelevel Gain Mixer Bias, & Digital Gain Calibration								✓			
IQ Impairment Calibration								✓			
Pulse Width Calibration				✓							
IQ Power Floor Calibration								✓			
Target IQ Power Calibration								✓			
1/f Corner Calibration								✓			



**Table 4-4 Performance Tests: Assemblies A1—A18**

Performance Tests	Replaced Assembly																	
	A1 Keyboard	A2 Display	A2DS1 Backlight	A3 Power Switch	A4 Inverter	A5 Sampler	A6 Frac-N	A7 Reference (Standard)	A7 Reference (UNR)	A8 Output (Analog)	A8 Output (Digital)	A9 YIG Driver	A10 ALC	A11 Pulse/Analog Mod Gen	A12 Low Band Fast Pulse 1E6	A13 IQ Multiplexer	A14 Baseband Generator	A18 CPU or BT1
The following performance tests are listed in the order that they should be performed to minimize changes in test equipment configurations.																		
Self Tests	✓	✓	✓	✓	✓	✓	✓	✓	✓	✓	✓	✓	✓	✓		✓	✓	✓
Maximum Levelled Output Power							✓			✓	✓		✓					
Power Level Accuracy										✓	✓		✓					
Internal Pulse Modulation Level Accuracy										✓	✓			✓	✓			
Internal Pulse Modulation Rise/Fall Time										✓	✓			✓	✓			
DC FM Carrier Offset							✓							✓				
Internal FM Frequency Response							✓					✓		✓				
External Phase Modulation Frequency Response							✓					✓		✓				
Internal FM Distortion							✓							✓				
Internal Phase Modulation Distortion							✓							✓				
External FM Deviation Accuracy							✓					✓		✓				
Internal Phase Modulation Deviation Accuracy							✓					✓		✓				
External Pulse Modulation ON/OFF Ratio										✓	✓			✓	✓			
Harmonic Spurious							✓	✓	✓	✓	✓							
Sub-Harmonic Spurious							✓	✓	✓									
Non-Harmonic Spurious						✓	✓	✓	✓	✓	✓							
Single-Sideband Phase Noise						✓	✓	✓	✓	✓	✓							
EVM and IQ Offset												✓				✓	✓	
External Digital Modulation Level Accuracy Relative to CW												✓				✓	✓	
Swept Frequency Accuracy							✓					✓						
<b>Optional Performance Test</b>																		
Timebase Aging Rate																		
<b>Functional Check</b> (Service Software – Utility)																		
Dual Arb																		✓

**Table 4-5 Performance Tests: Assemblies A19—A32**

Performance Tests	Replaced Assembly																	
	A19 Power Supply	A20 SMI [Source Module Interface]	A21 Rear Panel Interface	A22 Line Module	A23 Lowband Coupler/Detector	A24 20 GHz Coupler	A24 40 GHz Coupler	A25 20 GHz Detector	A25 40 GHz Detector	A25B Detector Bias Board	A26 MID [Microcircuit Interface Deck]	A27 40 GHz Doubler	A28 YIG Oscillator	A29 20 GHz Doubler	A30 Mod Filter with High Power (Opt IEA)	A30 Mod Filter with Standard Power	A31 Motherboard	A32 10 MHz Crystal Oscillator
The following performance tests are listed in the order that they should be performed to minimize changes in test equipment configurations.																		
Self Tests	✓	✓	✓	✓	✓	✓	✓	✓	✓	✓	✓	✓	✓	✓	✓	✓	✓	✓
Maximum Leveled Output Power					✓	✓	✓	✓	✓		✓	✓	✓	✓	✓	✓		
Power Level Accuracy					✓	✓	✓	✓	✓		✓		✓	✓	✓	✓		
Internal Pulse Modulation Level Accuracy															✓	✓		
Internal Pulse Modulation Rise/Fall Time															✓	✓		
DC FM Carrier Offset																		
Internal FM Frequency Response													✓					
External Phase Modulation Frequency Response													✓					
Internal FM Distortion																		
Internal Phase Modulation Distortion																		
External FM Deviation Accuracy													✓					
Internal Phase Modulation Deviation Accuracy													✓					
External Pulse Modulation ON/OFF Ratio															✓	✓		
Harmonic Spurious											✓	✓	✓	✓	✓	✓		
Sub-Harmonic Spurious												✓	✓	✓				
Non-Harmonic Spurious																	✓	✓
Single-Sideband Phase Noise													✓					✓
EVM and IQ Offset																		
External Digital Modulation Level Accuracy Relative to CW																		
Swept Frequency Accuracy																		
<b>Optional Performance Test</b>																		
Timebase Aging Rate																		✓
<b>Functional Check</b> (Service Software – Utility)																		
Dual Arb																		

**Table 4-6 Performance Tests: Assemblies A34, A35, AT1, B1, and RF Output Connector**

Performance Tests	Replaced Assembly				
	A34 Internal Hard Drive	A35 3 – 20 IQ Modulator	AT1 115 dB Attenuator	B1 Fan	RF Output Connector
<b>The following performance tests are listed in the order that they should be performed to minimize changes in test equipment configurations.</b>					
Self Tests		✓	✓	✓	✓
Maximum Leveled Output Power		✓	✓		✓
Power Level Accuracy		✓	✓		✓
Internal Pulse Modulation Level Accuracy					
Internal Pulse Modulation Rise/Fall Time					
DC FM Carrier Offset					
Internal FM Frequency Response					
External Phase Modulation Frequency Response					
Internal FM Distortion					
Internal Phase Modulation Distortion					
External FM Deviation Accuracy					
Internal Phase Modulation Deviation Accuracy					
External Pulse Modulation ON/OFF Ratio					
Harmonic Spurious		✓			
Sub-Harmonic Spurious					
Non-Harmonic Spurious				✓	
Single-Sideband Phase Noise					
EVM and IQ Offset		✓			
External Digital Modulation Level Accuracy Relative to CW		✓			
Swept Frequency Accuracy					
<b>Optional Performance Test</b>					
Timebase Aging Rate					
<b>Functional Check (Service Software – Utility)</b>					
Dual Arb					



---

# 5 Safety and Regulatory

This chapter provides information on the following:

- “General Safety Considerations” on page 5-2
- “Lithium Battery Disposal” on page 5-3
- “Assistance” on page 5-3
- “Certification” on page 5-3

The following safety notes are used throughout this manual. Familiarize yourself with each of the notes and its meaning before operating this instrument.

---

**CAUTION** Caution denotes a hazard. It calls attention to a procedure that, if not correctly performed or adhered to, would result in damage to or destruction of the product. Do not proceed beyond a caution sign until the indicated conditions are fully understood and met.

---

---

**WARNING** Warning denotes a hazard. It calls attention to a procedure which, if not correctly performed or adhered to, could result in injury or loss of life. Do not proceed beyond a warning note until the indicated conditions are fully understood and met.

---

## General Safety Considerations

The following safety notes apply specifically to signal generators. These notes also appear in other chapters of this service guide as required.

---

**WARNING** These servicing instructions are for use by qualified personal only. To avoid electrical shock, do not perform any servicing unless you are qualified to do so.

---

---

**WARNING** The opening of covers or removal of parts is likely to expose dangerous voltages. Disconnect the product from all voltage sources before starting to open.

---

---

**WARNING** The detachable power cord is the instrument disconnecting device. It disconnects the mains circuits from the mains supply before other parts of the instrument. The front panel switch is only a standby switch and is not a LINE switch (disconnecting device).

---

---

**WARNING** The power cord is connected to internal capacitors that may remain live for 5 seconds after disconnecting the plug from its power supply.

---

---

**WARNING** This is a Safety Class 1 Product (provided with a protective earthing ground incorporated in the power cord). The mains plug shall only be inserted in a socket outlet provided with a protective earth contact. Any interruption of the protective conductor inside or outside of the product is likely to make the product dangerous. Intentional interruption is prohibited.

---

---

**WARNING** Replace battery only with the same or equivalent type recommended. Discard used batteries according to manufacturer's instructions.

---

---

**WARNING** If this product is to be used as specified, the protection provided by the equipment could be impaired. This product must be used in a normal condition (in which all means for protection are intact) only.

---

---

**CAUTION** Many of the assemblies in this instrument are very susceptible to damage from electrostatic discharge (ESD). Perform service procedures only at a static-safe workstation and wear a grounding strap.

---

---

## Lithium Battery Disposal

When the battery on the A14 CPU is exhausted and/or ready for disposal, dispose of it according to your country's requirements. You can return the battery to your nearest Agilent Technologies Sales and Service office for disposal, if required.

**Figure 5-1**



---

## Assistance

Product maintenance agreements and other customer assistance agreements are available for Agilent Technologies products. For any assistance, contact your nearest Agilent Technologies sales and service office (see [“Agilent Sales and Service Offices”](#) on page 1-117).

---

## Certification

Agilent Technologies Company certifies that this product met its published specifications at the time of shipment from the factory. Agilent Technologies further certifies that its calibration measurements are traceable to the United States National Institute of Standards and Technology, to the extent allowed by the Institute's calibration facility, and to the calibration facilities of other International Standards Organization members.





**Numerics**

- 10 MHz crystal oscillator (Option UNR)
  - replacement, [2-90](#)
- 115 dB attenuator (Option 1E1)
  - replacement, [2-56](#), [2-58](#)
- 20 GHz
  - doubler
    - replacement, [2-78](#)
  - highband coupler
    - replacement, [2-62](#)
  - highband detector
    - replacement, [2-66](#)
- 3-20 GHz I/Q modulator
  - replacement, [2-96](#)
- 40 GHz
  - doubler
    - replacement, [2-74](#)
  - highband coupler
    - replacement, [2-64](#)
  - highband detector
    - replacement, [2-68](#)
- 6dB PAD
  - replacement, [2-92](#)

**A**

- accessories
  - test cable, [3-61](#)
- ADC adjustment, troubleshooting, [1-73](#)
- adjustments
  - required after repair, [4-1](#)
  - troubleshooting, [1-71](#), [1-73](#)
- Agilent, sales and service offices, [1-117](#)
- ALC
  - replacement, [2-26](#)
- antistatic materials, [3-62](#)
- assemblies list, [3-6](#)
- assembly replacement
  - 10 MHz crystal oscillator (Option UNR), [2-90](#)
  - 115 dB attenuator (Option 1E1), [2-56](#), [2-58](#)
  - 20 GHz doubler, [2-78](#)
  - 20 GHz highband coupler, [2-62](#)
  - 20 GHz highband detector, [2-66](#)
  - 3-20 GHz I/Q modulator, [2-96](#)
  - 40 GHz double, [2-74](#)
  - 40 GHz highband coupler, [2-64](#)
  - 40 GHz highband detector, [2-68](#)
  - 6 db PAD, [2-92](#)
  - ALC, [2-26](#)
  - baseband generator, [2-34](#)
  - baseband generator interface, [2-36](#)
  - battery, [2-40](#)
  - CPU, [2-38](#)
  - display, [2-14](#)
  - display backlight, [2-16](#)
  - fan, [2-98](#)
  - frac-n, [2-22](#)
  - front panel, [2-9](#)

- highband detector bias board, [2-70](#)
- I/Q MUX, [2-32](#)
- instrument cover, inner, [2-7](#)
- instrument cover, outer, [2-5](#)
- internal hard drive, [2-94](#)
- inverter, [2-20](#)
- keyboard, [2-12](#)
- line module, [2-54](#)
- low band coupler/detector, [2-60](#)
- microcircuit interface deck (MID), [2-72](#)
- modulator filter, [2-80](#)
- motherboard, [2-83](#), [2-86](#)
- output, [2-22](#)
- power supply, [2-42](#)
- power switch, [2-18](#)
- preparation, [2-2](#)
- pulse modulator board, [2-30](#)
- pulse/analog modulation generator, [2-28](#)
- rear panel, [2-44](#), [2-47](#)
- rear panel interface, [2-52](#)
- reference, [2-22](#)
- sampler, [2-22](#)
- source module interface, [2-50](#)
- YIG driver, [2-24](#)
- YIG oscillator, [2-76](#)
- assembly-level troubleshooting, [1-10](#)

**B**

- baseband generator
  - replacement, [2-34](#)
- baseband generator interface
  - replacement, [2-36](#)
- battery
  - disposal, [5-3](#)
  - replacement, [2-40](#)

**C**

- cables, [3-19](#)
  - bottom view, [3-34](#)
  - front panel, [3-26](#)
  - microcircuit deck view, [3-32](#)
  - rear panel, [3-29](#), [3-31](#)
  - top view, [3-27](#)
- certification, [5-3](#)
- coupler
  - 20 GHz highband
    - replacement, [2-62](#)
  - 40 GHz highband
    - replacement, [2-64](#)
  - low band
    - replacement, [2-60](#)
- CPU
  - replacement, [2-38](#)
  - troubleshooting, [1-4](#)
- crystal oscillator
  - 10 MHz
    - replacement, [2-90](#)

---

# Index

## D

- detector
  - 20 GHz highband replacement, [2-66](#)
  - 40 GHz highband replacement, [2-68](#)
  - highband bias board replacement, [2-70](#)
  - low band replacement, [2-60](#)
- digital modulation, description, [1-108](#)
- display
  - replacement, [2-14](#)
- display backlight
  - replacement, [2-16](#)
- driver
  - YIG, [2-24](#)

## E

- electrostatic discharge supplies, [3-62](#)

## F

- fan
  - replacement, [2-98](#)
- frac-n
  - replacement, [2-22](#)
- front panel
  - cables, [3-26](#)
  - replacement, [2-9](#)
  - subassemblies replacement
    - display, [2-15](#)
    - display backlight, [2-17](#)
    - inverter, [2-21](#)
    - power switch, [2-19](#)

## H

- hardware, [3-37](#)
- hardware list, [3-6](#)
- harmonics, troubleshooting, [1-80](#)
- highband detector bias board
  - replacement, [2-70](#)

## I

- I/Q MUX
  - replacement, [2-32](#)
- instrument cover replacement, [2-5](#), [2-7](#)
- internal hard drive
  - replacement, [2-94](#)
- inverter
  - replacement, [2-20](#)

## K

- keyboard
  - replacement, [2-12](#)

## L

- line module
  - replacement, [2-54](#)
- lists
  - assemblies and hardware options, [3-6](#)
  - cables, [3-19](#)
  - hardware, [3-37](#)
  - replaceable assemblies, [2-3](#)
- lithium battery
  - disposal, [5-3](#)
  - replacement, [2-40](#)
- low band coupler/detector
  - replacement, [2-60](#)

## M

- microcircuit interface deck (MID)
  - replacement, [2-72](#)
- modulator filter
  - replacement, [2-80](#)
- motherboard
  - replacement, [2-83](#), [2-86](#)

## N

- non-harmonic spurious, troubleshooting, [1-83](#)

## O

- options
  - descriptions, [3-5](#)
  - UNR, troubleshooting, [1-84](#)
- oscillator
  - 10 MHz crystal, [2-90](#)
  - YIG, [2-76](#)
- output
  - replacement, [2-22](#)
- overall block diagram, [1-85](#)

## P

- performance tests
  - required after repair, [4-1](#)
  - troubleshooting failures, [1-74](#)
- phase noise, troubleshooting, [1-84](#)
- post-repair procedures, [4-1](#)
- power supply
  - replacement, [2-42](#)
  - troubleshooting, [1-17](#)
- power switch
  - replacement, [2-18](#)
- pulse modulator board
  - replacement, [2-30](#)
- pulse/analog modulation generator
  - replacement, [2-28](#)

## R

- rear panel

replacement, [2-44](#), [2-47](#)

rear-panel interface  
replacement, [2-52](#)

reference  
replacement, [2-22](#)

reference/synthesis loop  
block diagram, [1-95](#)  
description, [1-95](#)

repair  
adjustments required, [4-1](#)  
performance tests required, [4-1](#)  
troubleshooting, [1-1](#)

replaceable parts  
assemblies, [2-3](#)  
hardware, [3-37](#)  
ordering information, [3-2](#)

RF path  
block diagram, [1-110](#)  
description, [1-103](#)  
troubleshooting, [1-76](#)

## **S**

safety, general considerations, [5-2](#)

sales and service offices, [1-117](#)

sampler  
replacement, [2-22](#)

self-tests  
overview, [1-115](#)  
running, [1-3](#)  
troubleshooting  
10xx, [1-47](#)  
11xx, [1-49](#)  
12xx, [1-51](#)  
13xx, [1-56](#)  
16xx, [1-59](#)  
22xx, [1-62](#)  
2xx, [1-32](#)  
3xx, [1-34](#)  
4xx, [1-35](#)  
6xx, [1-38](#)  
7xx, [1-41](#)  
9xx, [1-45](#)

service  
Agilent sales and service offices, [1-117](#)  
packaging signal generator, [1-118](#)

source module interface  
replacement, [2-50](#)

spurious, harmonic, troubleshooting, [1-80](#)  
spurious, non harmonic, troubleshooting, [1-83](#)

## **T**

troubleshooting, [1-1](#)

## **U**

unlevels, troubleshooting, [1-67](#)  
unlocks, troubleshooting, [1-64](#)

## **Y**

YIG driver  
replacement, [2-24](#)  
YIG oscillator  
replacement, [2-76](#)

